

LAND OF LAYERS

Fé Ramakers

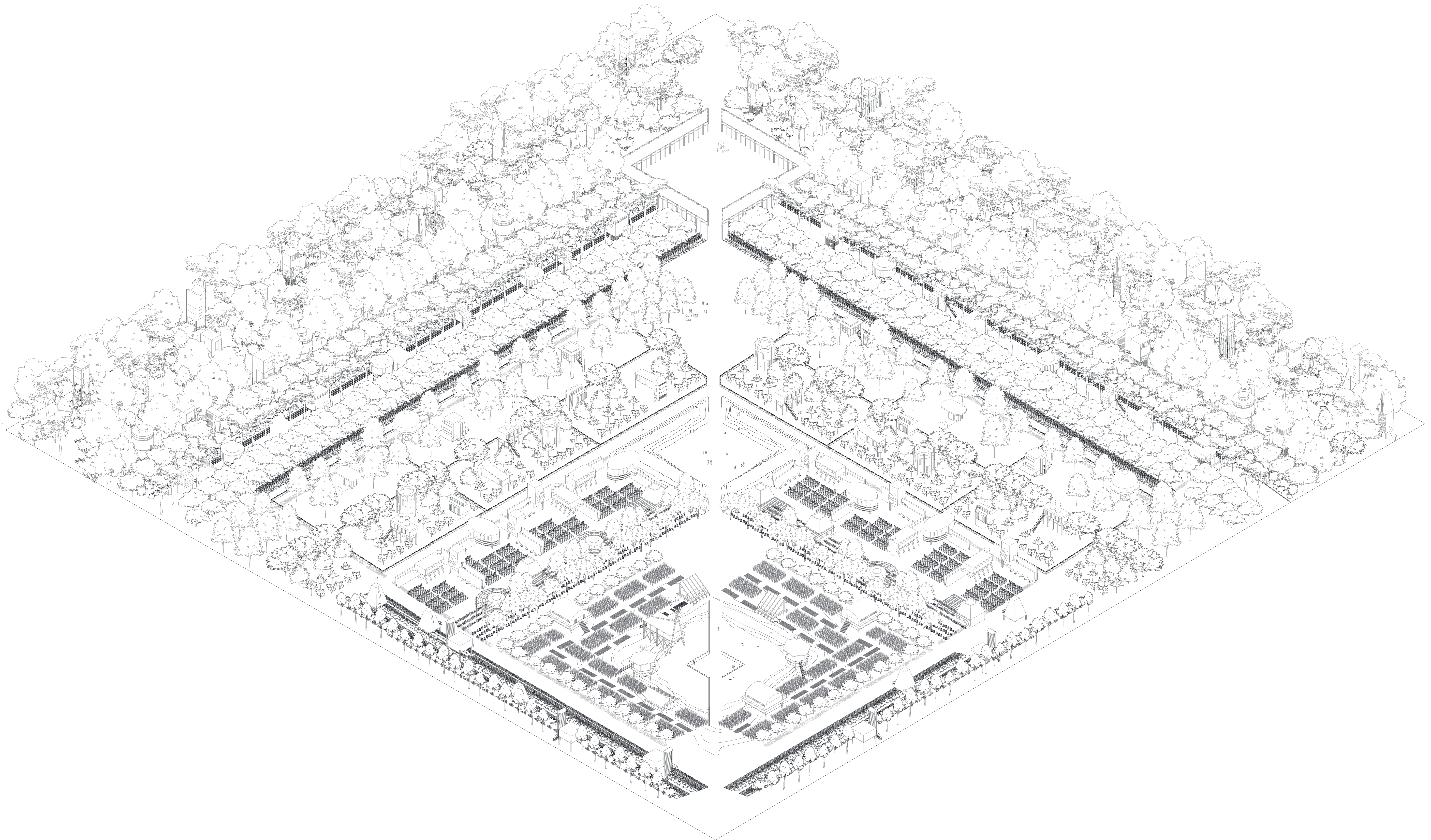

TOTAL PLAN

LAND OF LAYERS

Fé Ramakers

Between crops and trees, you enter the farm. A strip of open space cuts through the dense vegetation, creating a view all the way through the landscape. You see the hilly land going from a low, wet area, all the way to a dryer forest.

Walking all the way though, you pass ten different layers, each with their own agriculture, architecture and nature.

Soon you will see how all the elements in this farm have multiple functions with which they interact with each other. Like the oak tree, providing shelter and acorns for the pigs, and wood to grow mushrooms on. And the house that has an owl nest, so the owls can protect the crops.

In this way endless connections between agriculture, architecture and nature are made, to create a resilient, rich system.

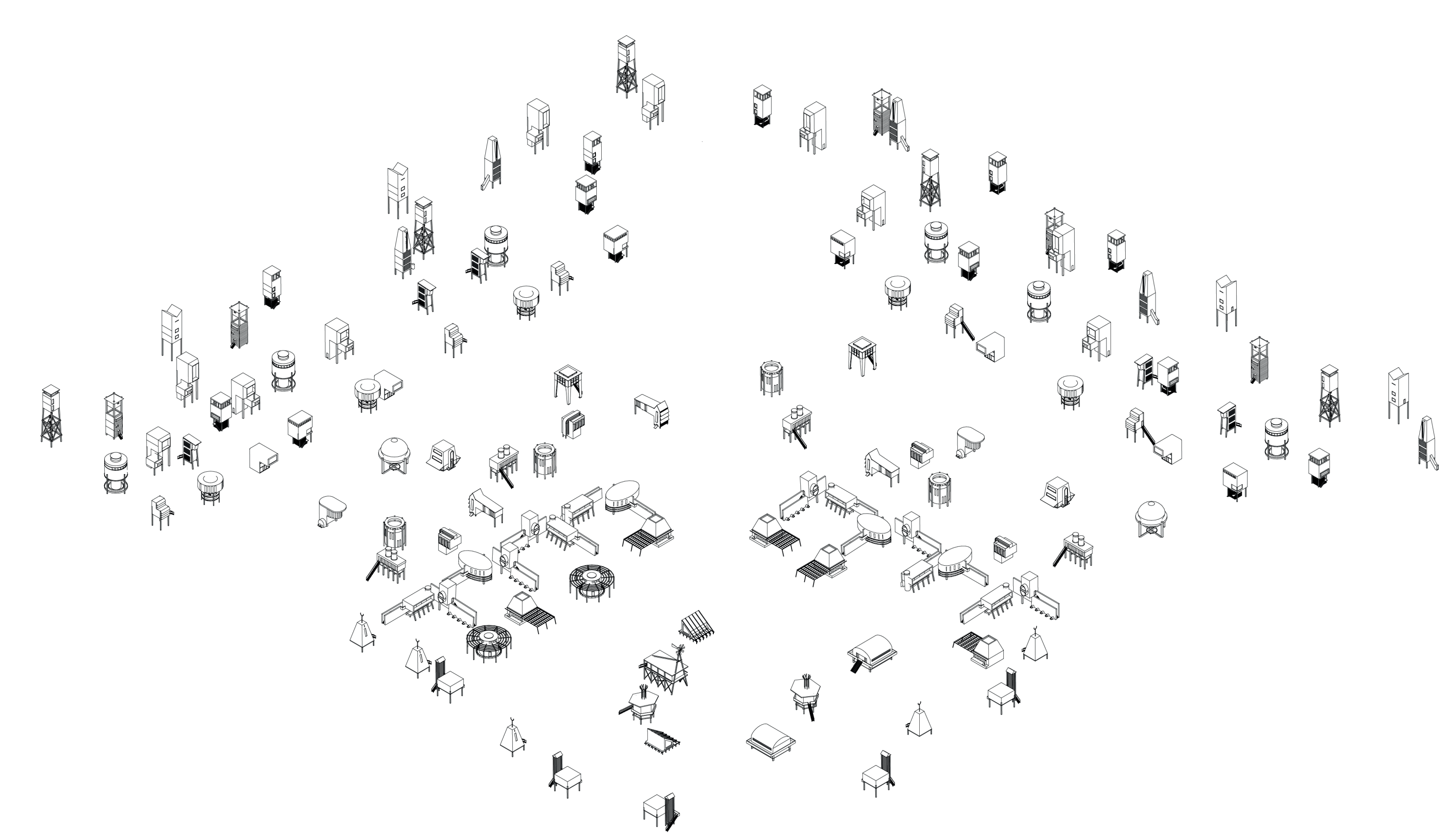
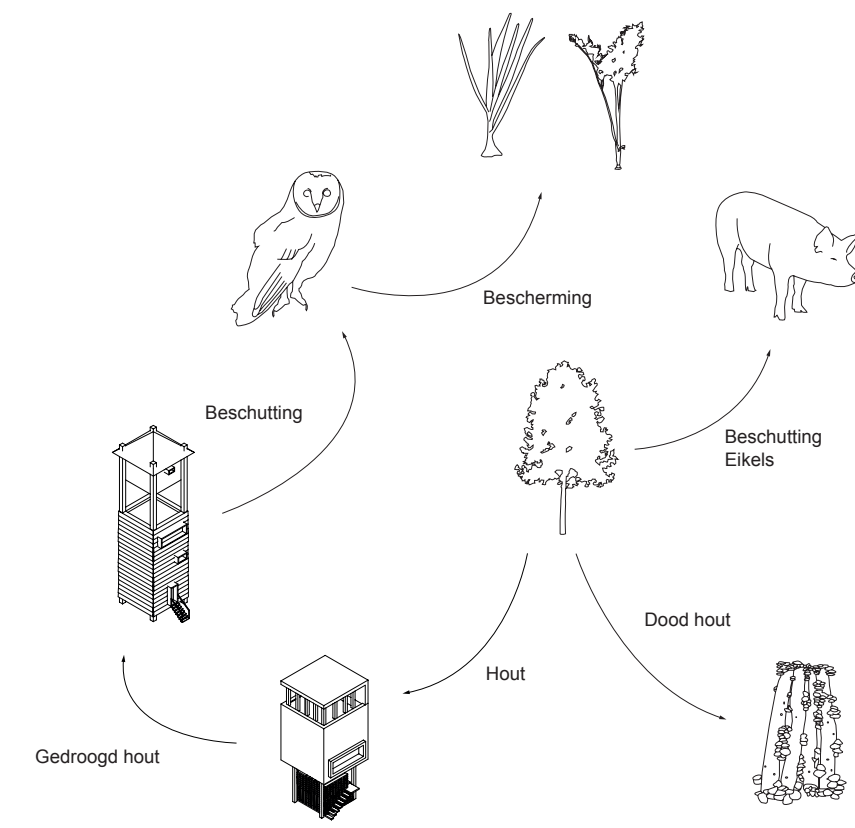
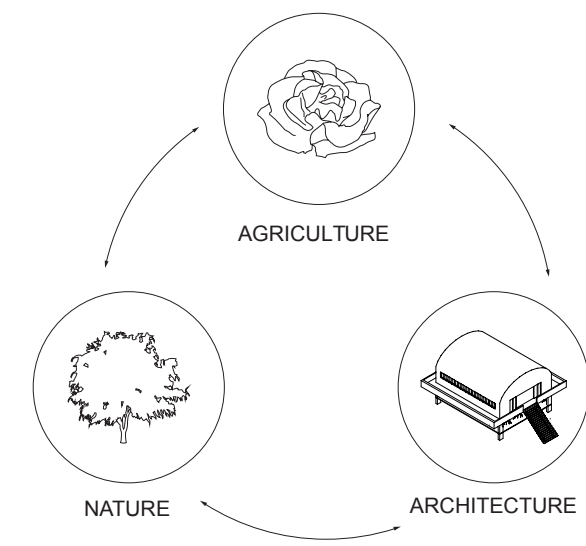

CONCEPT



CATALOGUE (CROP TYPES) AGRICULTURE

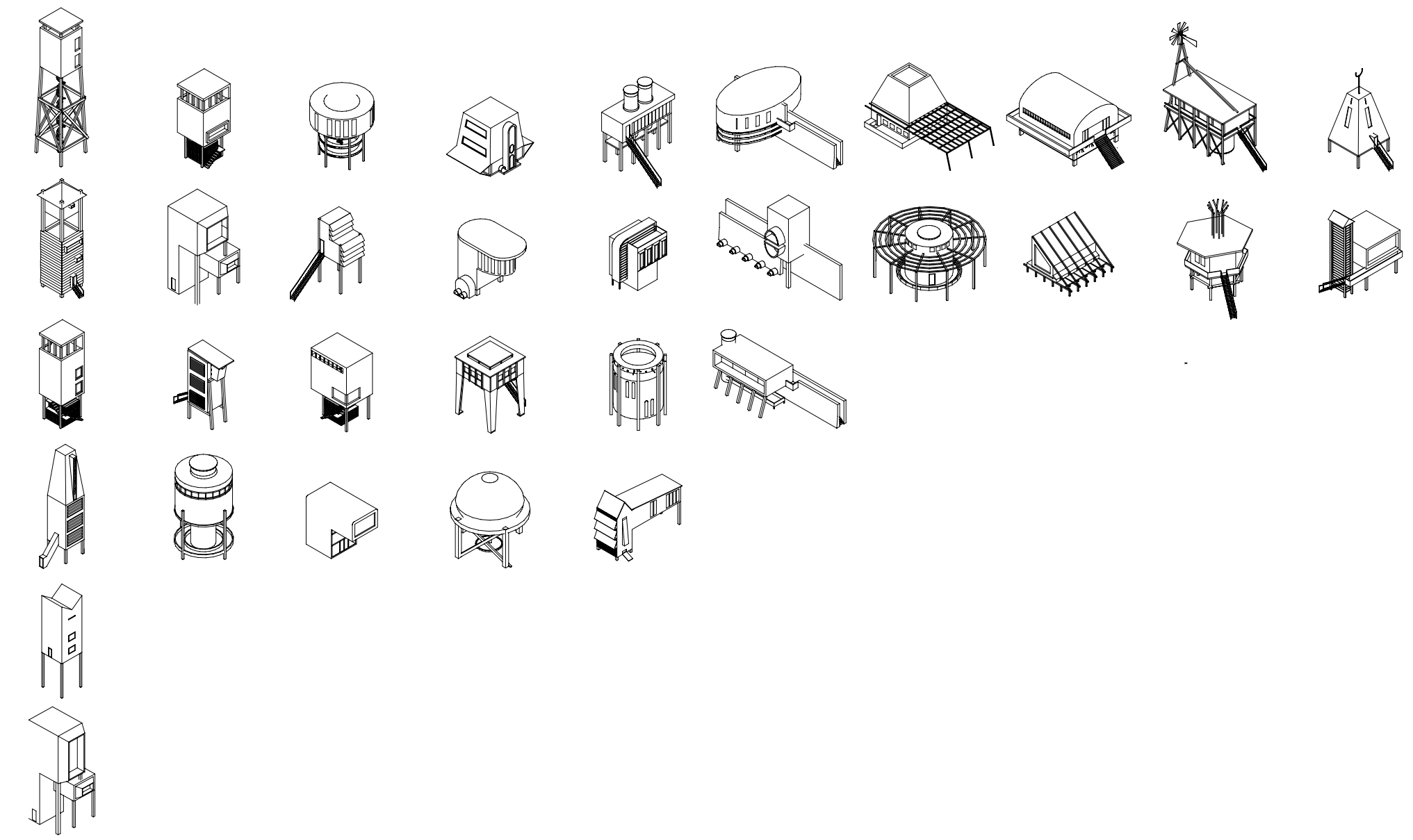

CATALOGUE (HOUSING TYPES) ARCHITECTURE

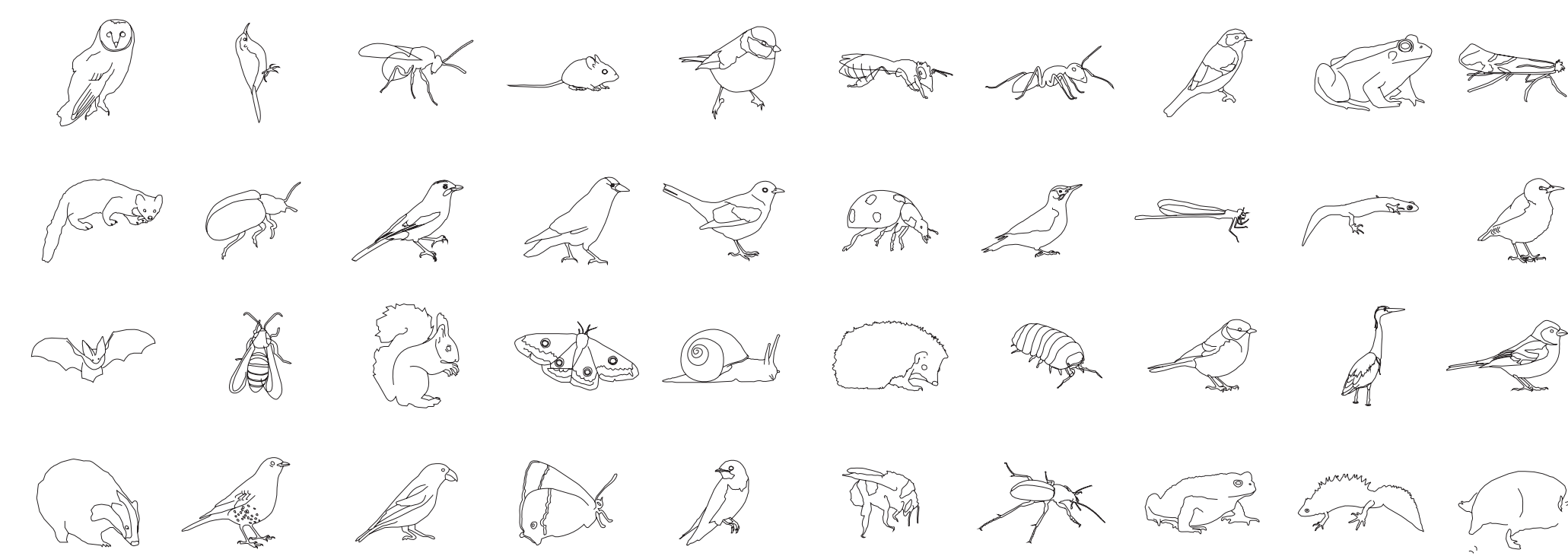

CATALOGUE (NATURAL SPECIES) NATURE

MODEL

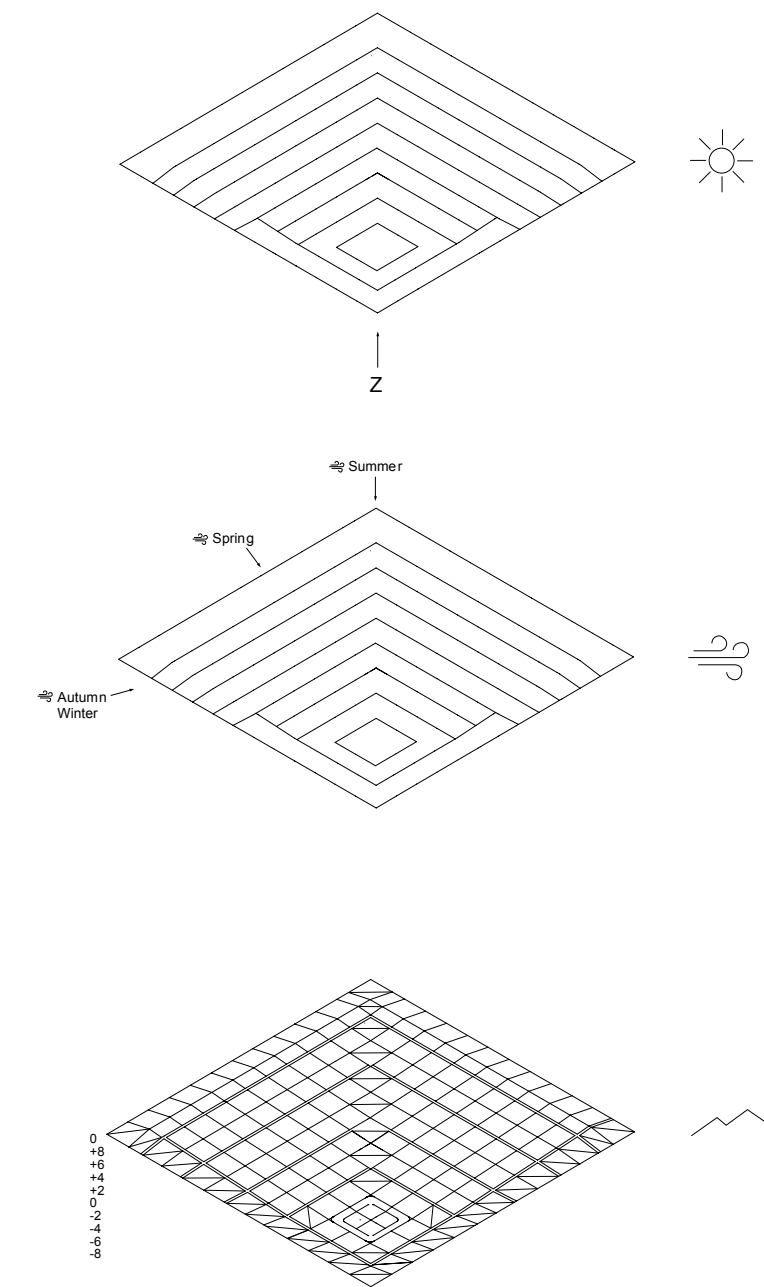

SYSTEM

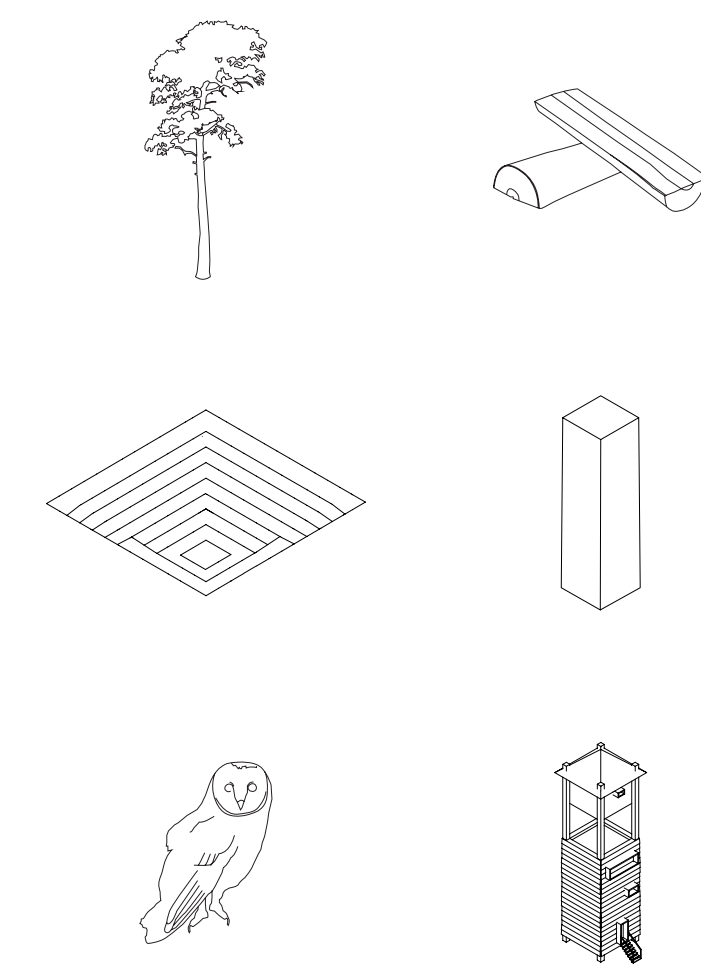

SYSTEM

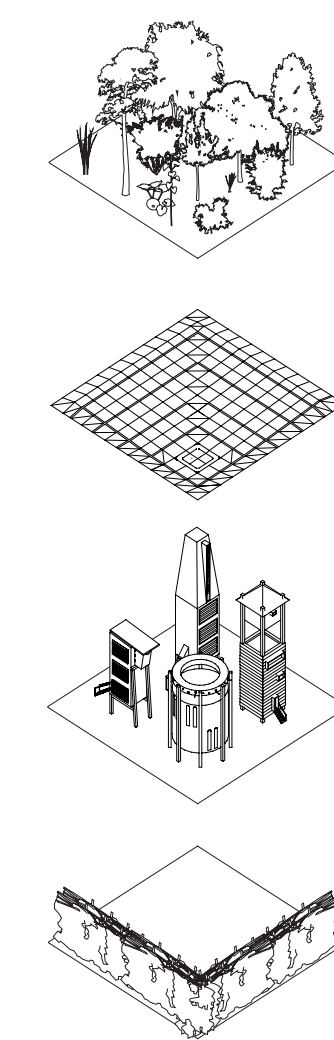

SYSTEM

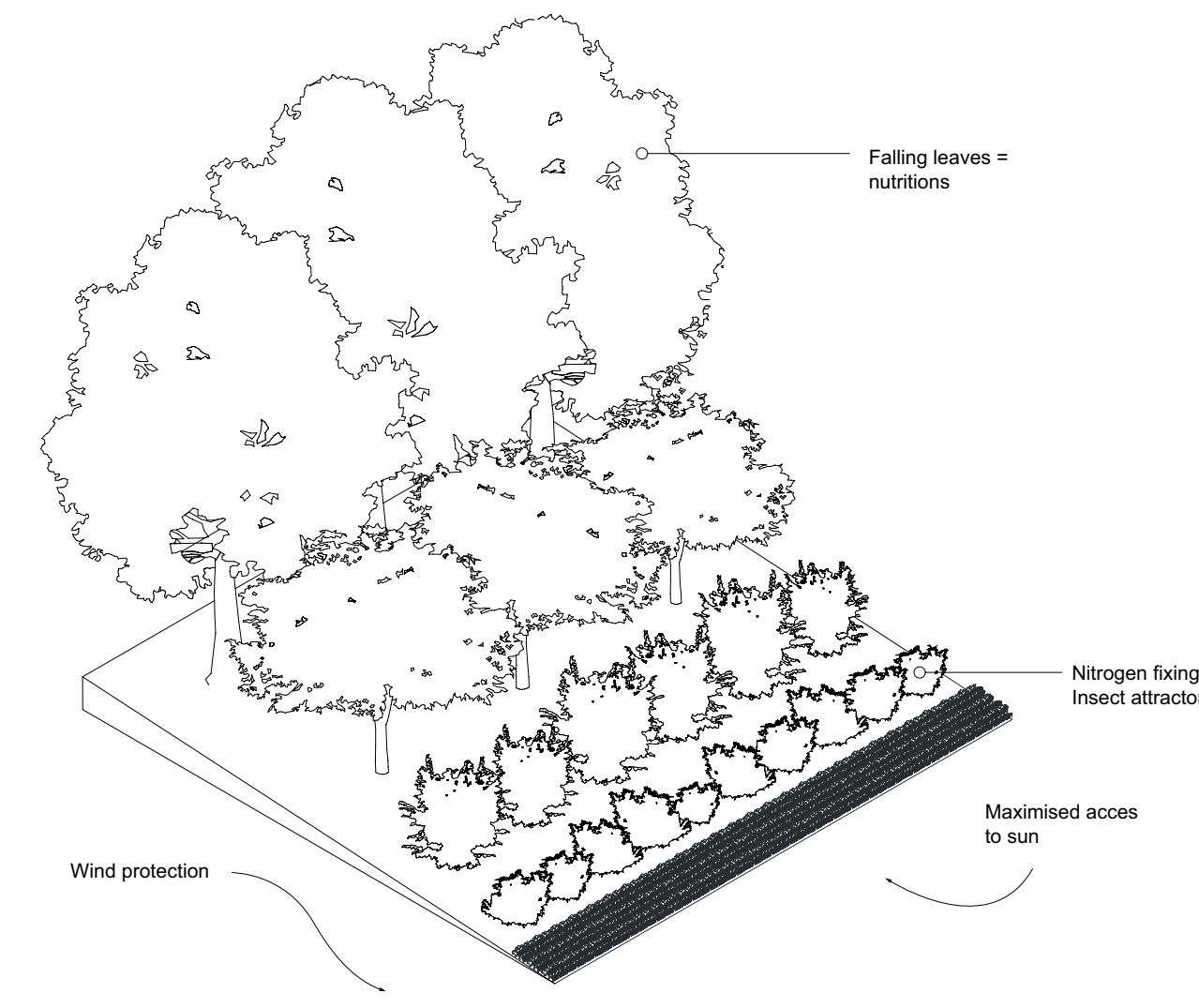

EXAMPLE

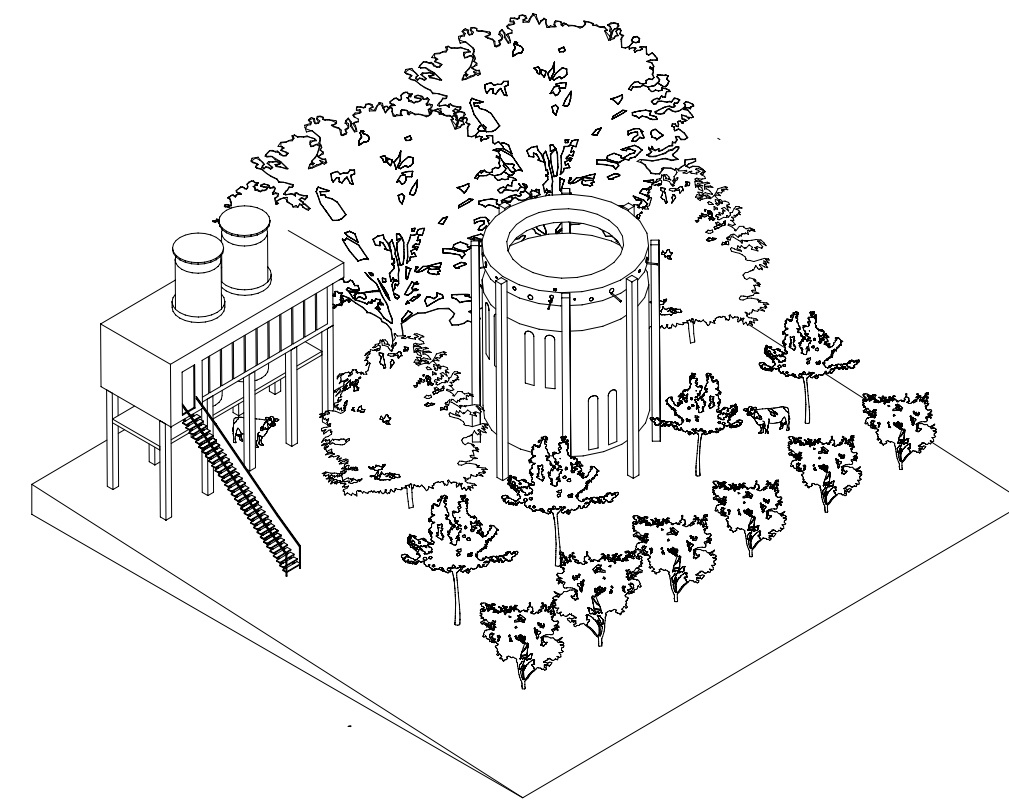

EXAMPLE

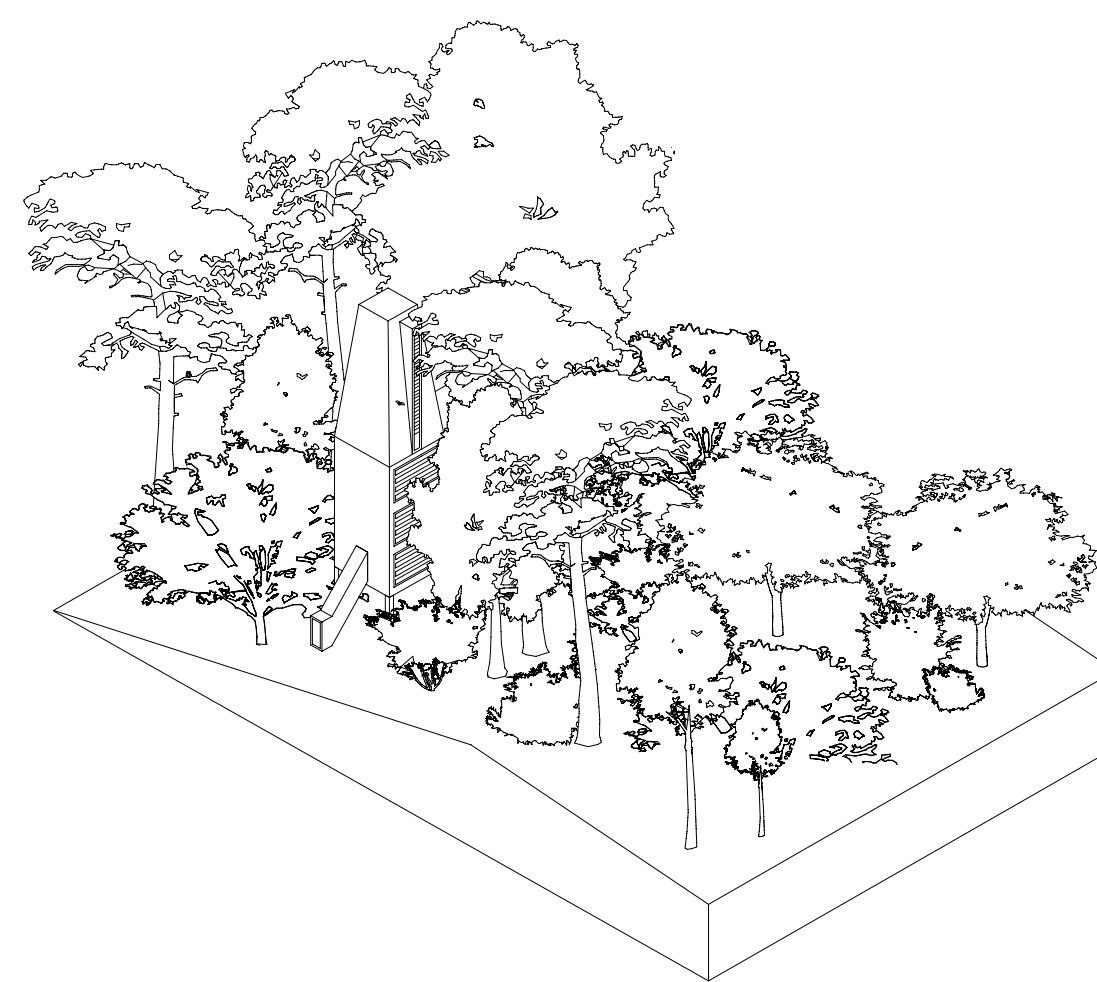

EXAMPLE

ARCHITECTURE

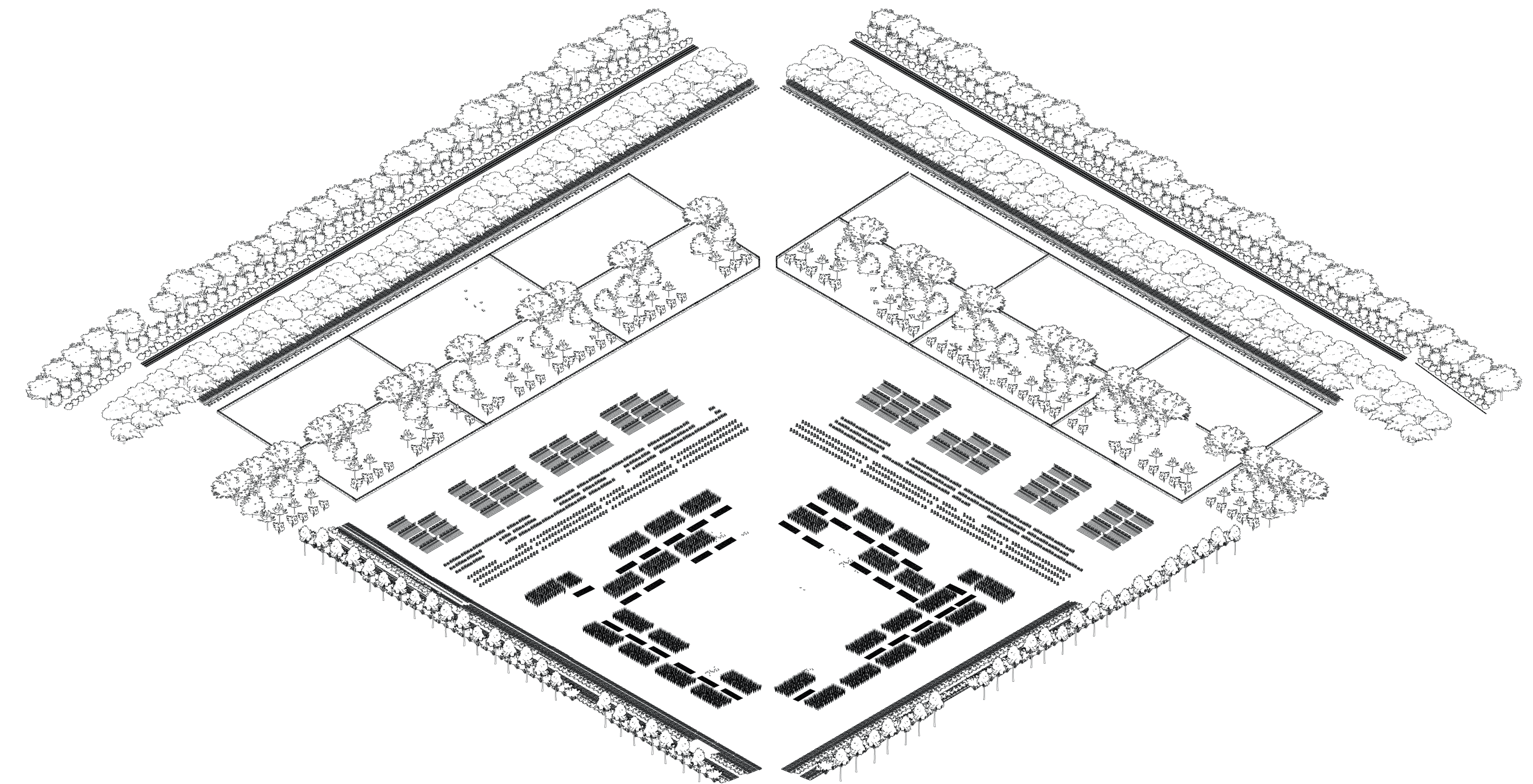

AGRICULTURE

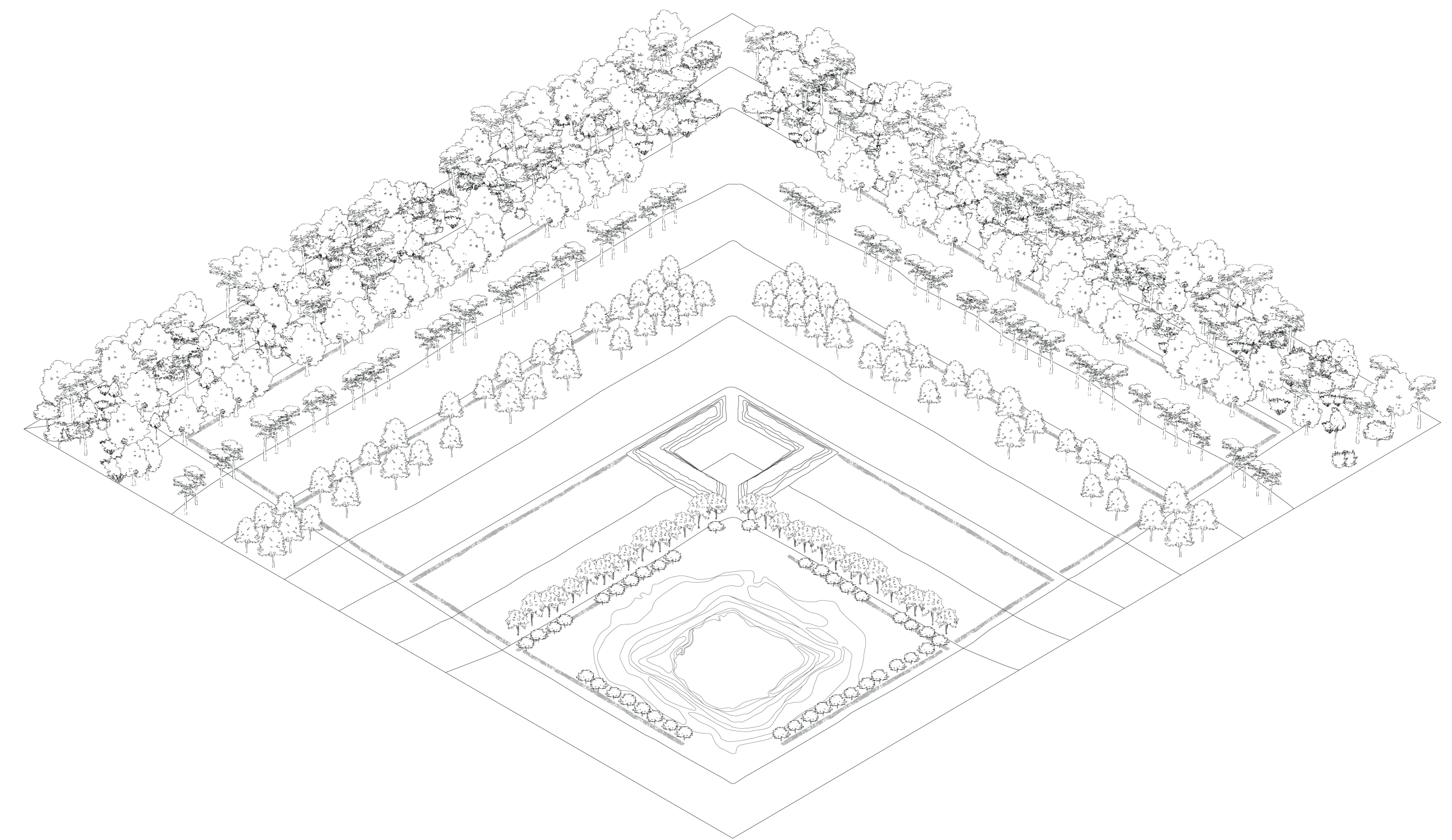

NATURE