

SWEET LAKE CITY

STEFAN BROUWER - EINDPRESENTATIE 18-06-2020

ANALYSE

TERRASWONINGEN VAN DER WERFFSTRAAT

ARCHITECT W.H. VERSCHOOR, 1970



TERRASWONINGEN VAN DER WERFFSTRAAT

ARCHITECT W.H. VERSCHOOR, 1970

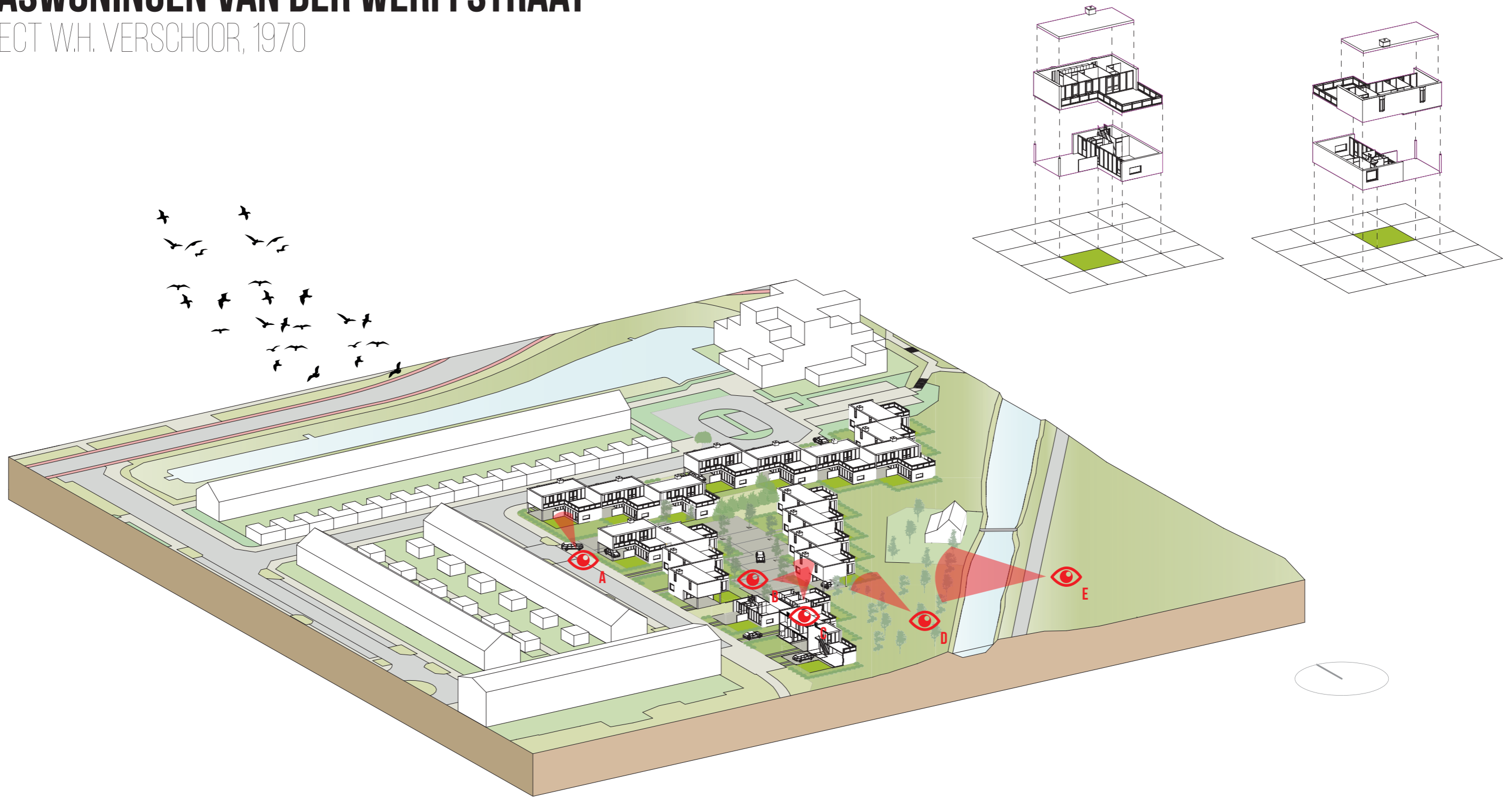

TERRASWONINGEN VAN DER WERFFSTRAAT

ARCHITECT W.H. VERSCHOOR, 1970

GRID

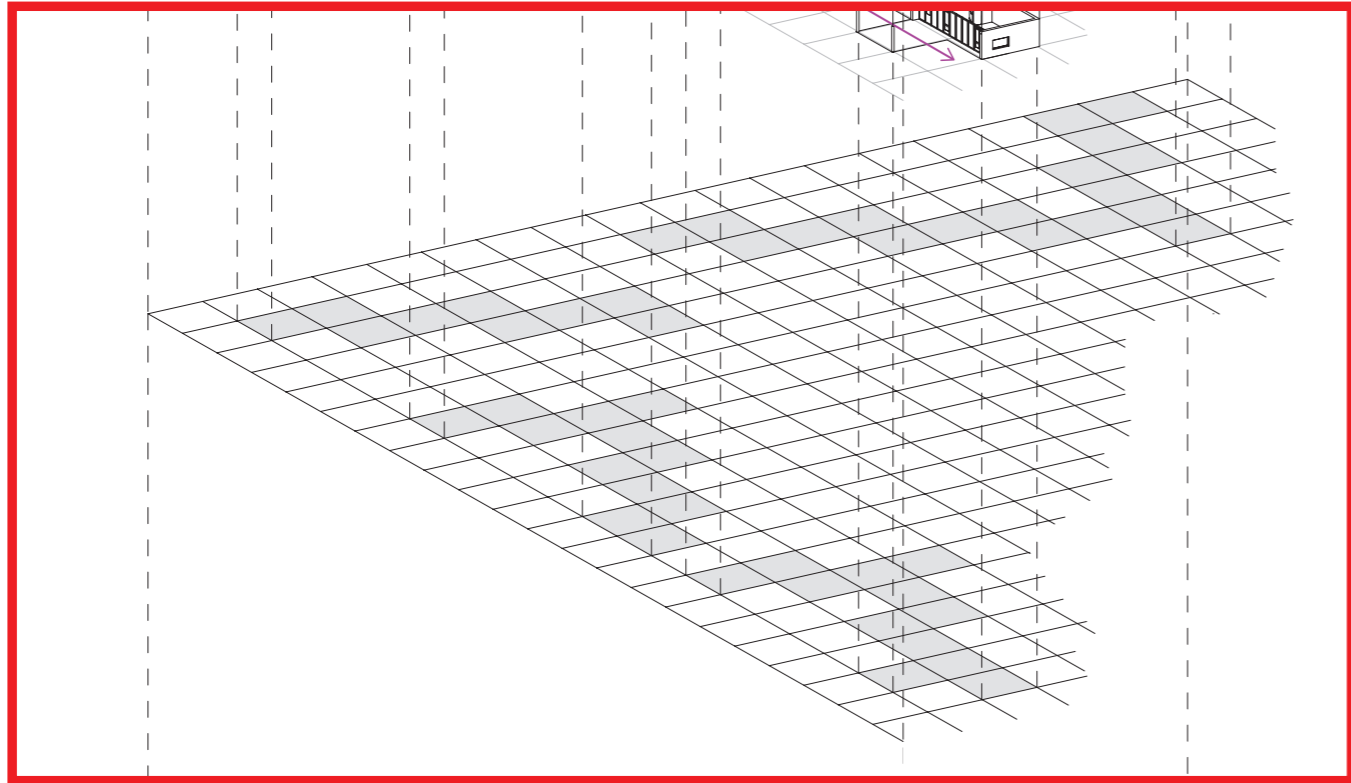

DRAGER VAN INVULLING EN DIMENSIONERING

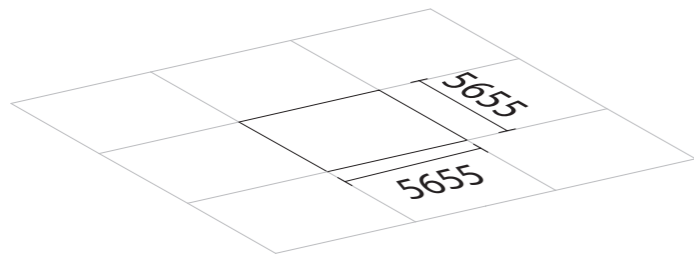

Zonering

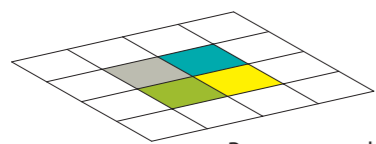

Begane grond

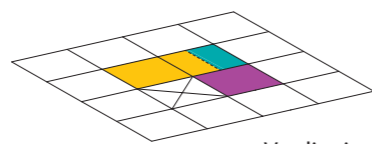

Verdieping

- Wonen
- Carport
- Patio

- Slapen
- Ondersteunend
- Dakterras

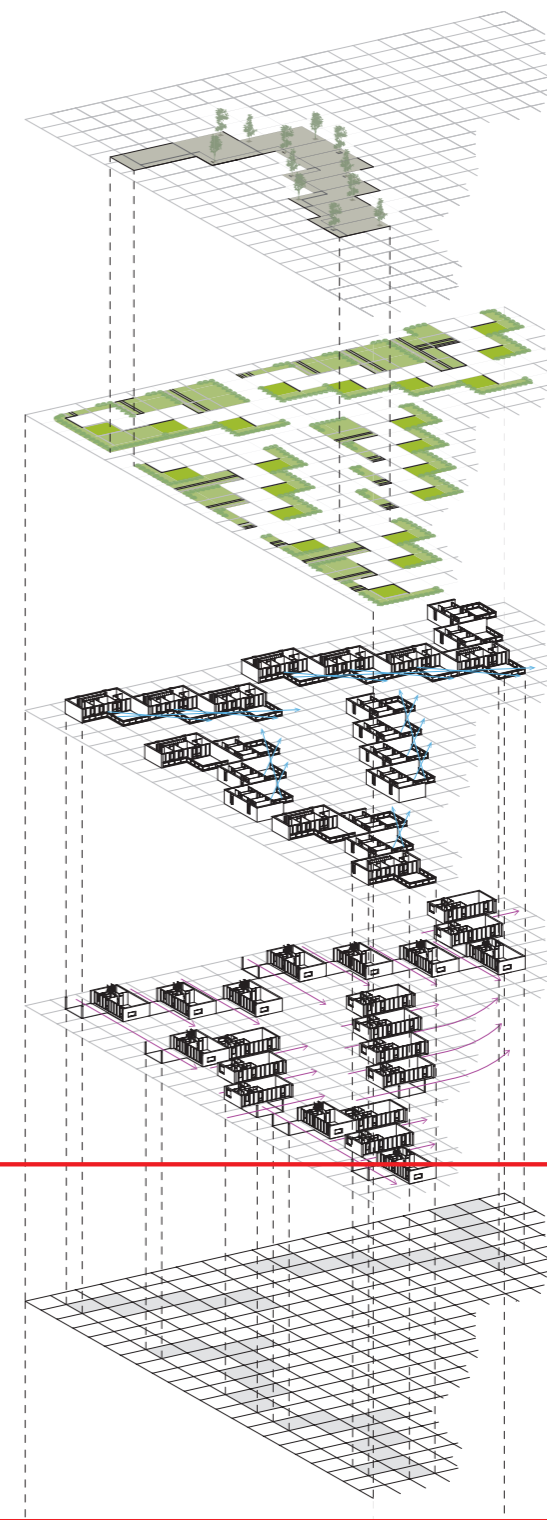

WOONERF

VOOR- EN ACHTERTUINEN

VERDIEPING

BEGANE GROND

GRID

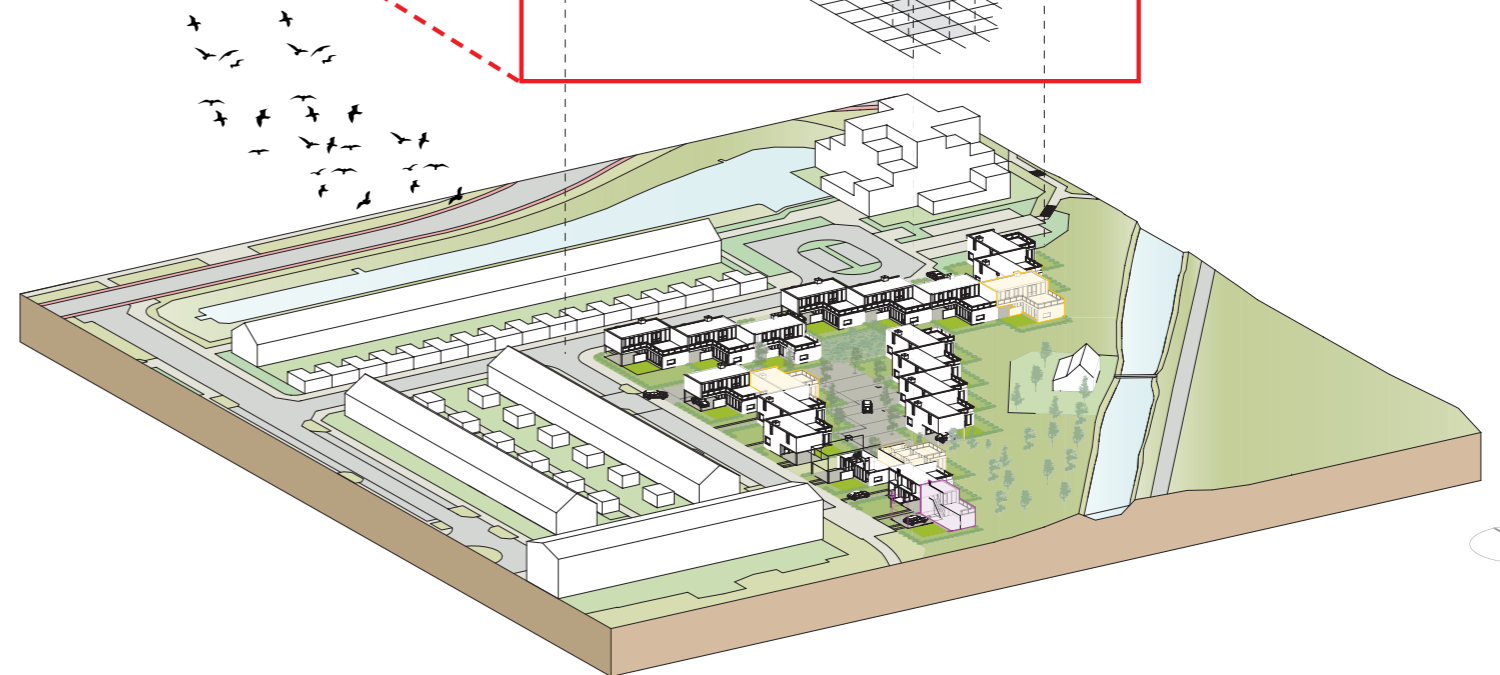

TERRASWONINGEN VAN DER WERFFSTRAAT

ARCHITECT W.H. VERSCHOOR, 1970

VOOR- EN ACHTERTUINEN

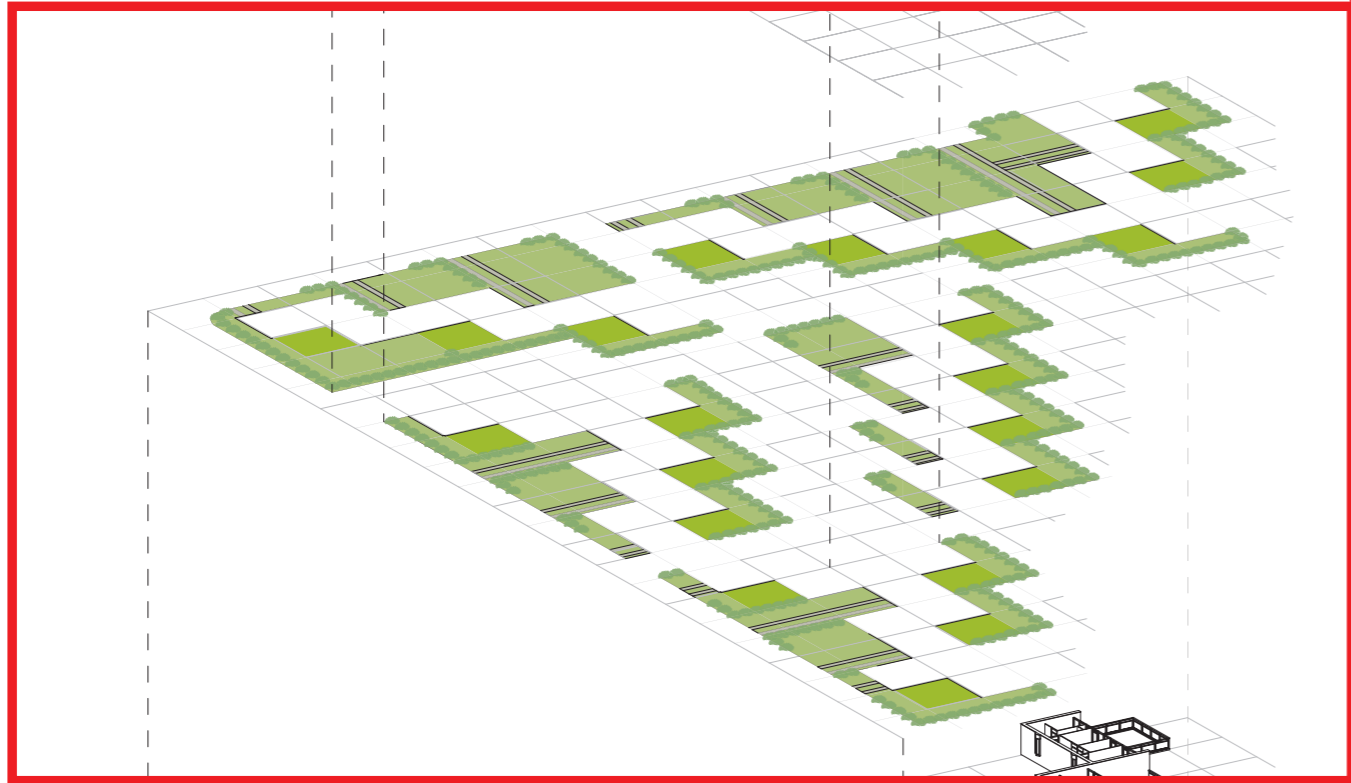

1972 (OPLEVERING)

OPENBARE OPZET PATIOS

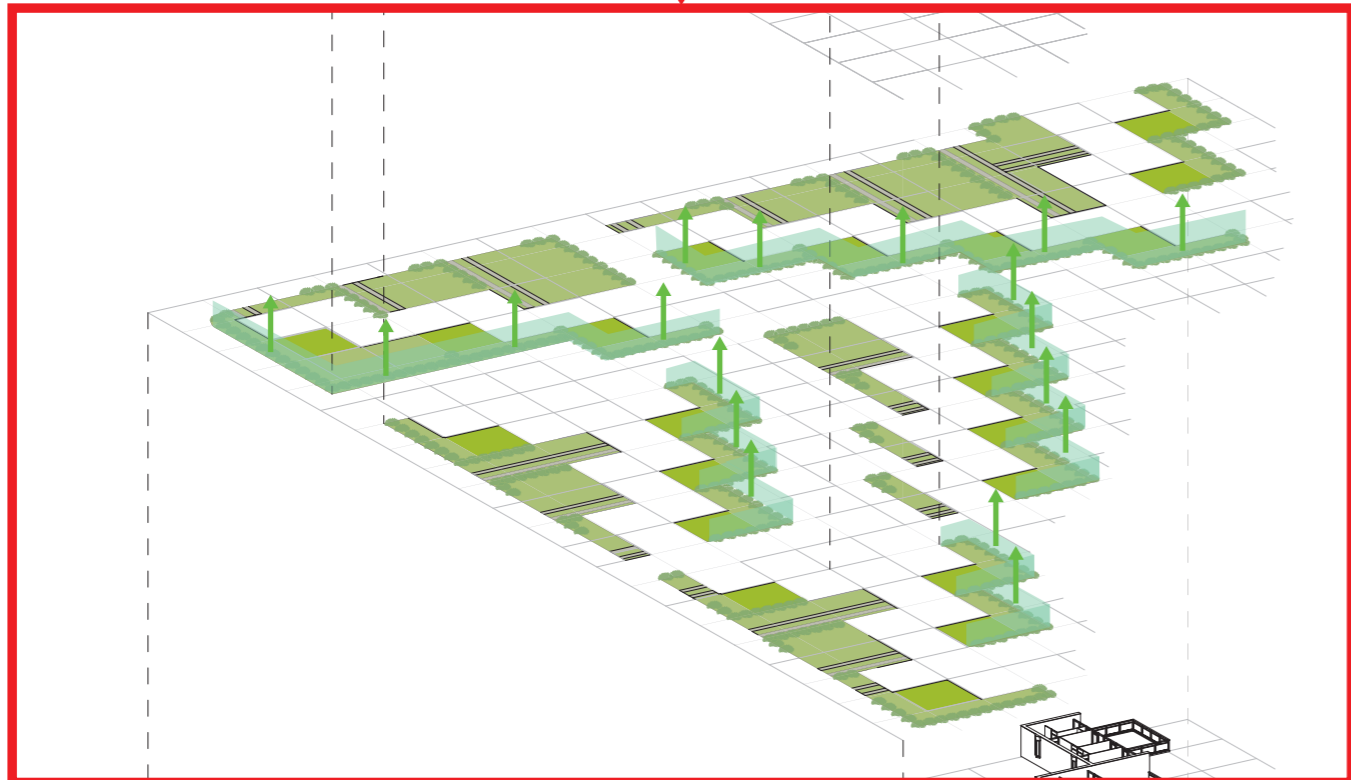

1975

PRIVATISERING EN TOEËIGENING

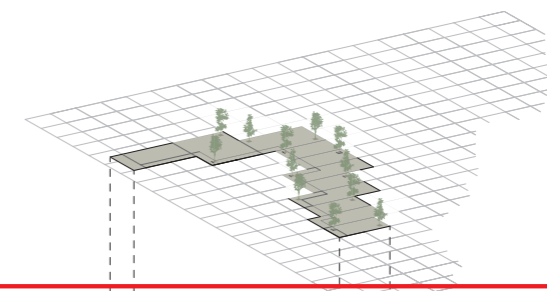

WOONERF

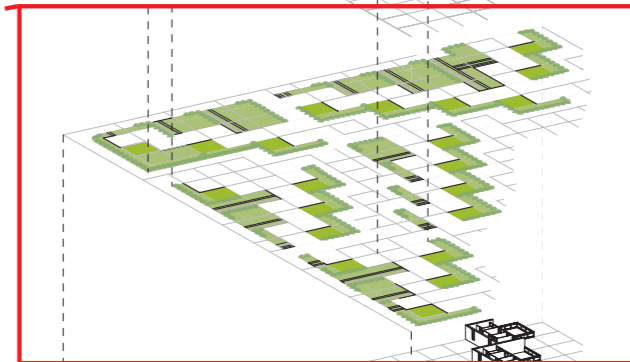

VOOR- EN ACHTERTUINEN

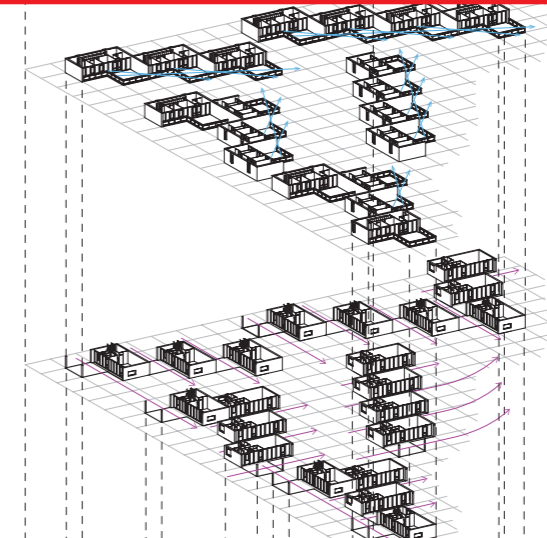

VERDIEPING

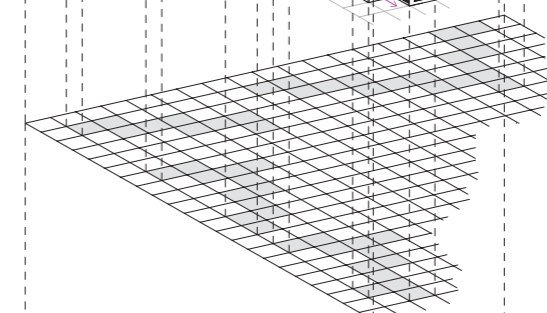

BEGANE GROND

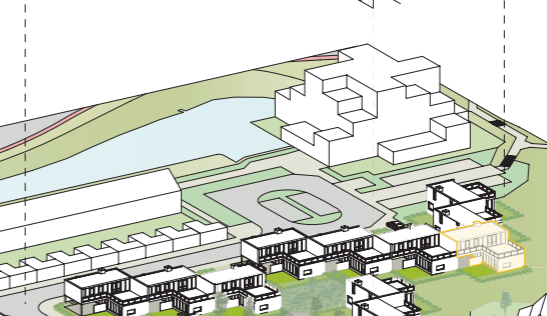

GRID

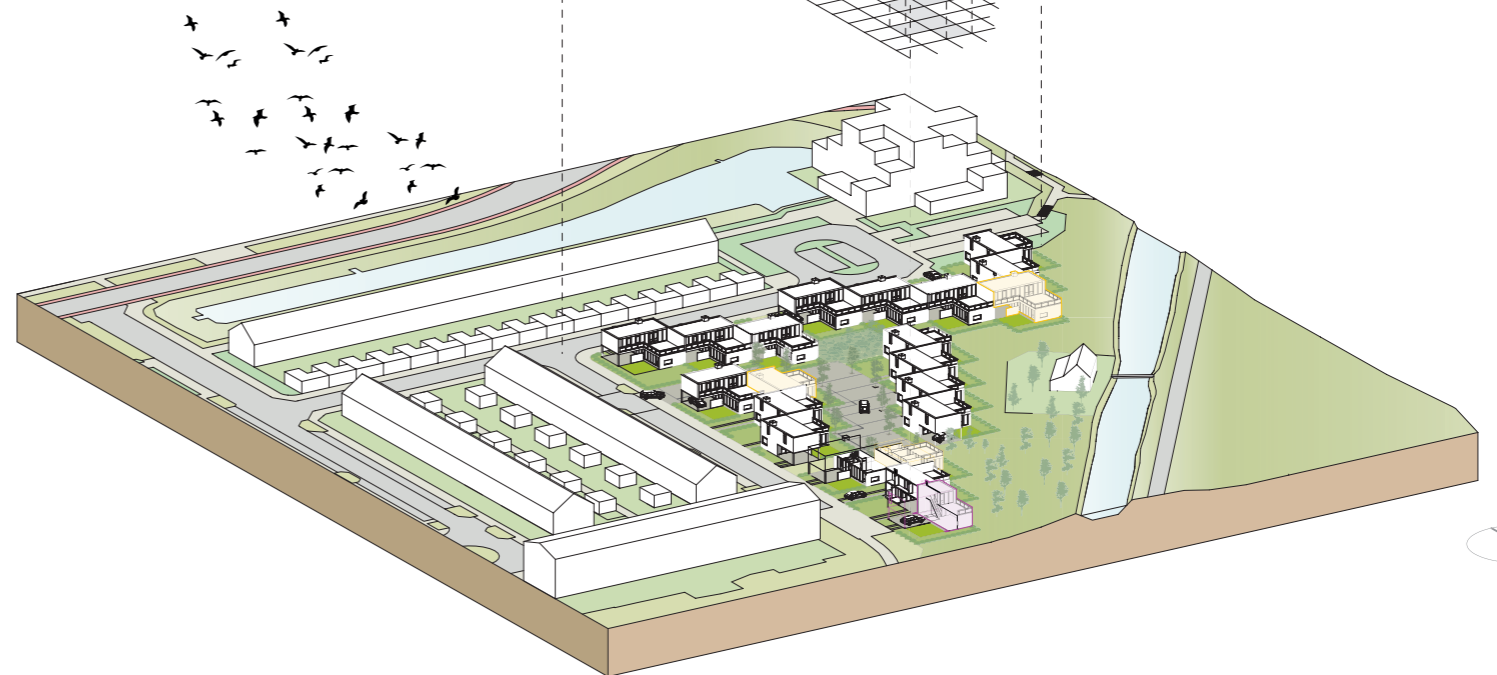

TERRASWONINGEN VAN DER WERFFSTRAAT

ARCHITECT W.H. VERSCHOOR, 1970

WOONERF

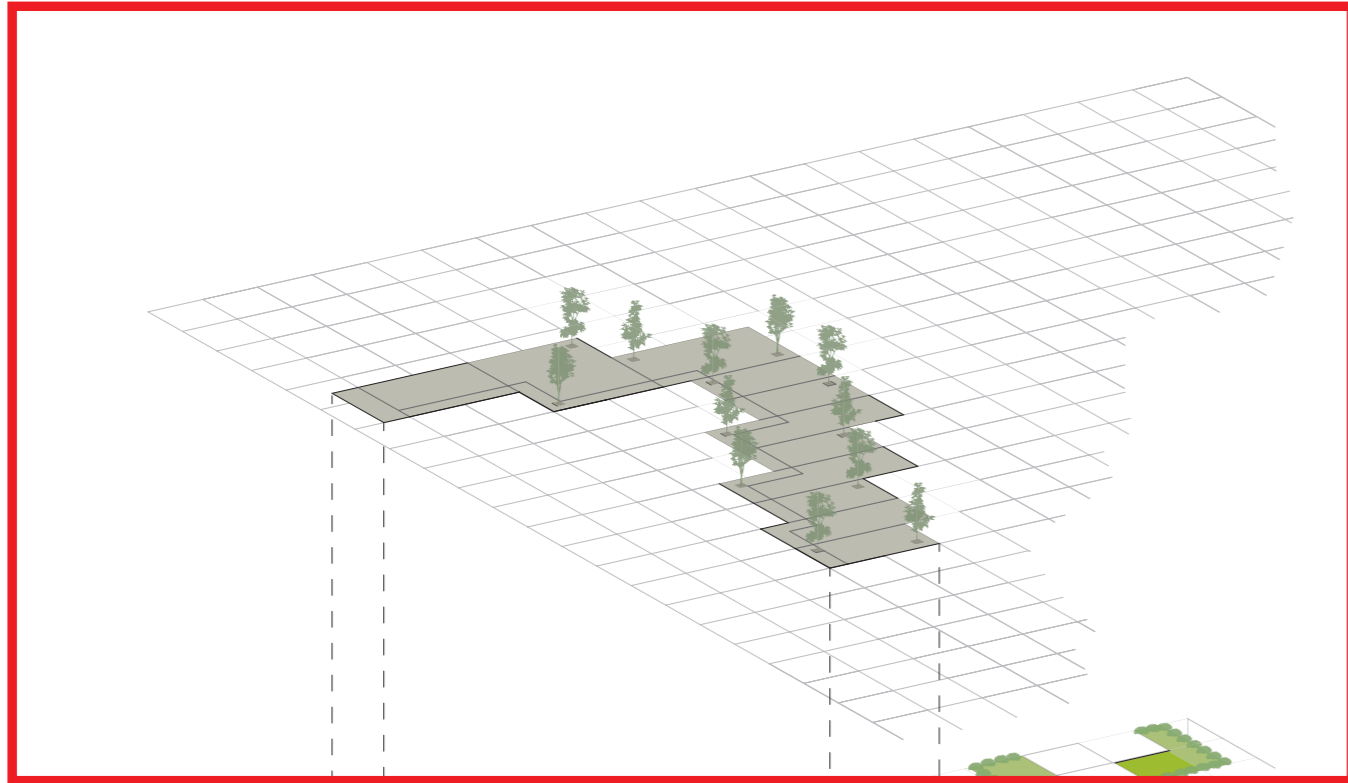

COLLECTIEVE 'SHARED-SPACE'

WOONERF

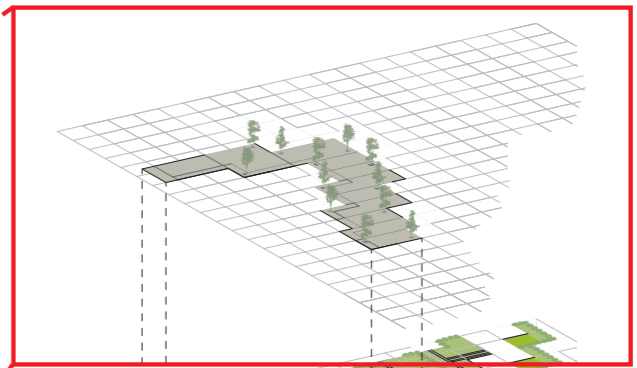

VOOR- EN ACHTERTUINEN

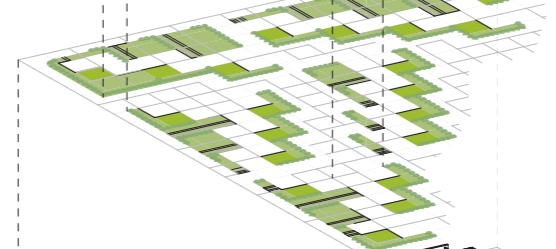

VERDIEPING

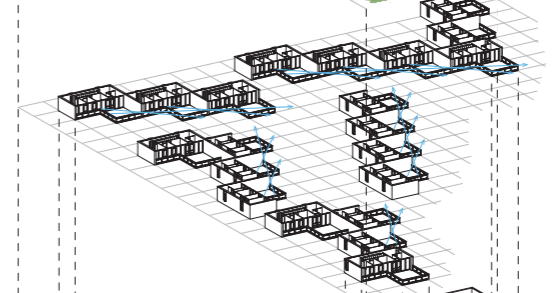

BEGANE GROND

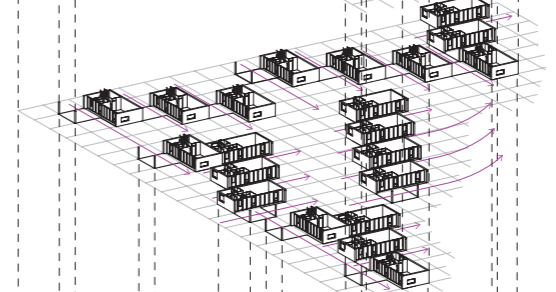

GRID

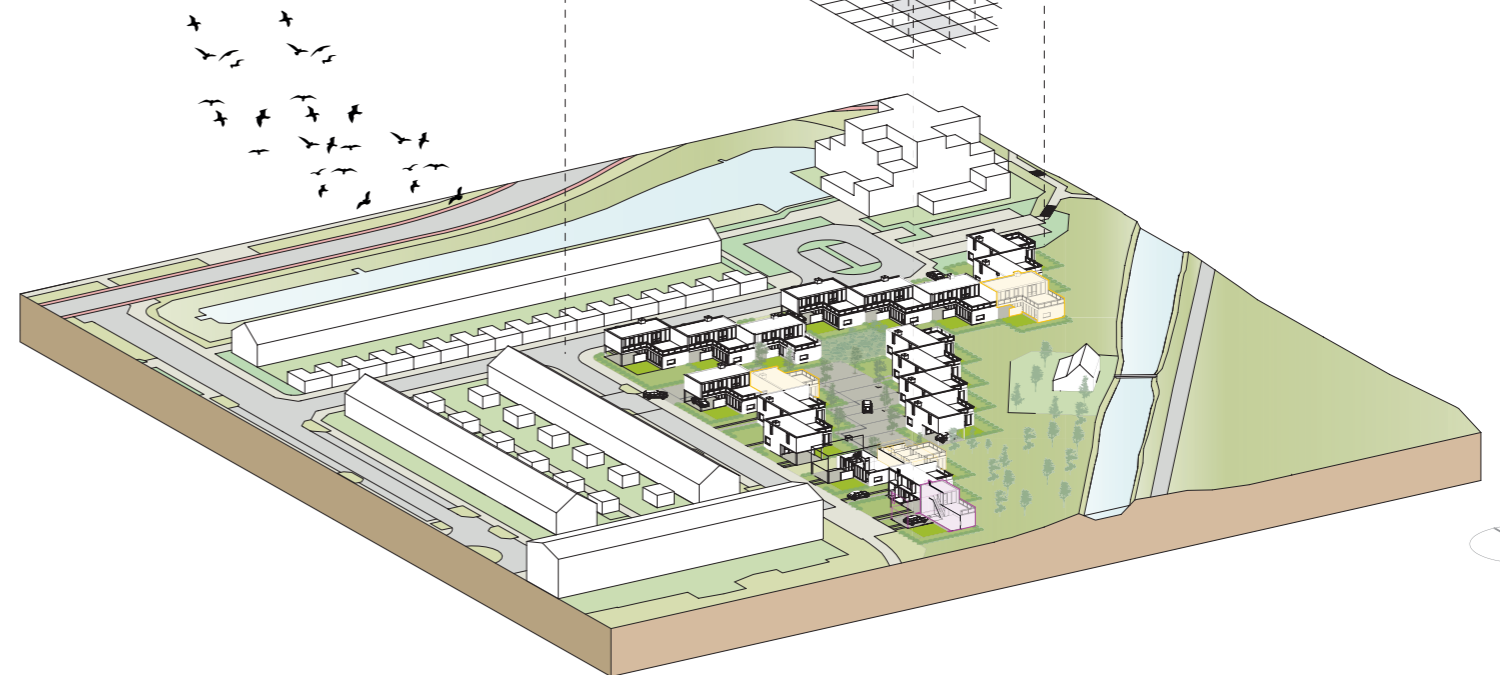
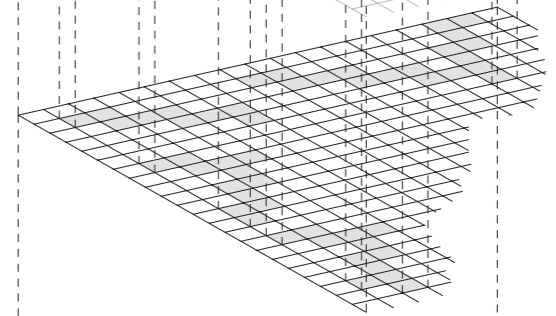

TERRASWONINGEN VAN DER WERFFSTRAAT

ARCHITECT W.H. VERSCHOOR, 1970

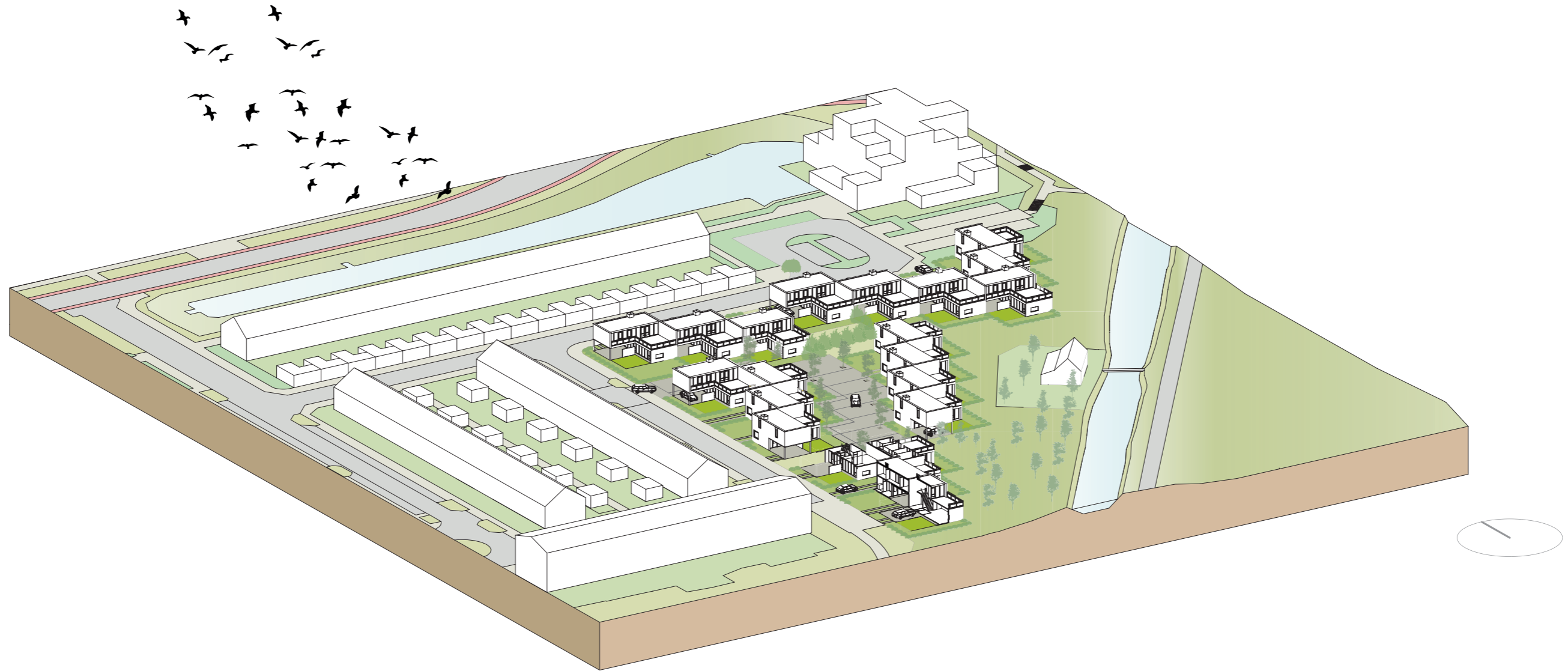

TERRASWONINGEN 2.0 AFRIKAWEG

STEFAN BROUWER, 2020



TERRASWONINGEN 2.0 AFRIKAWEG

STEFAN BROUWER, 2020

FUR-THEMA: SOCIAAL-CULTURELE VERBONDENHEID

1. INCLUSIVITEIT

MIX VAN VERSCHILLENDE WOONKLASSEN

+WOONGARRIÈRE IN EIGEN WIJK

2. COLLECTIVITEIT/BUURT-WIJK GEDACHTE

SAMEN DOEN, SAMEN DELEN

+ACTIVITETEN- EN ONTMOETINGSPLEINEN, STADSPARK

3. PROGRAMMAMIX OP KLEINE SCHAAL

KINDERDAGOPVANG, KLEINE WINKELS, CAFÉS, REPAIRSHOPS ETC.

+(COMMERCIEËLE) IN PLINT NIEUW STADSPARK

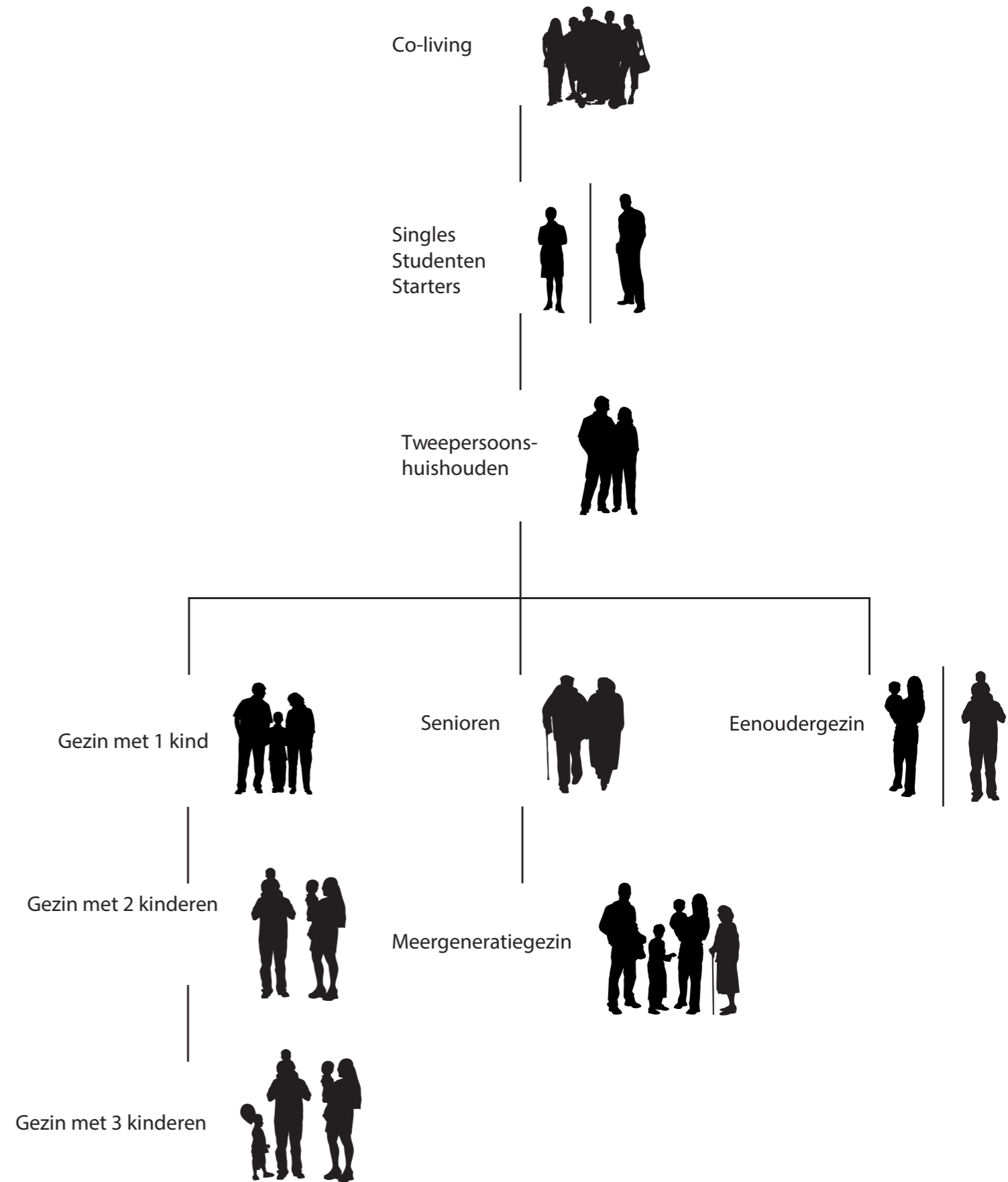

TERRASWONINGEN 2.0 AFRIKAWEG

STEFAN BROUWER, 2020

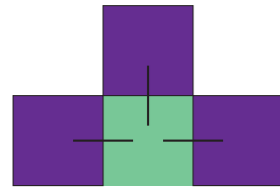

Studio's
36m²

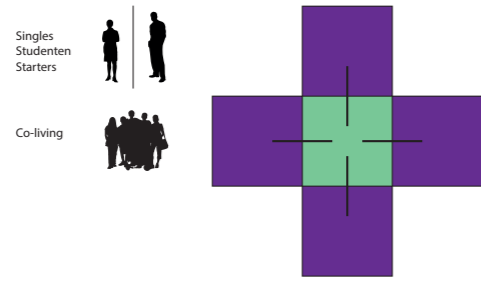

Studio's
36m²

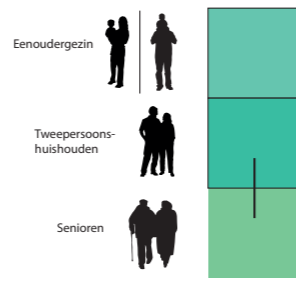
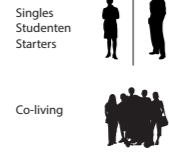

Appartement
72m²

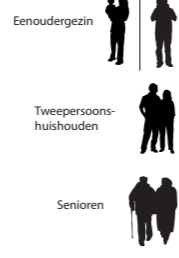

2 kamer-woning
108m²

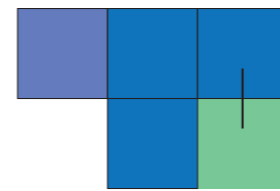

3 kamer-woning
144m²

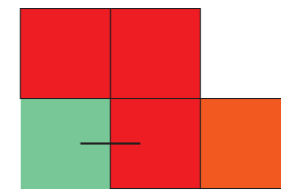

3 kamer-woning
144m²

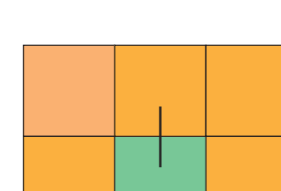

4 kamer-woning
180m²

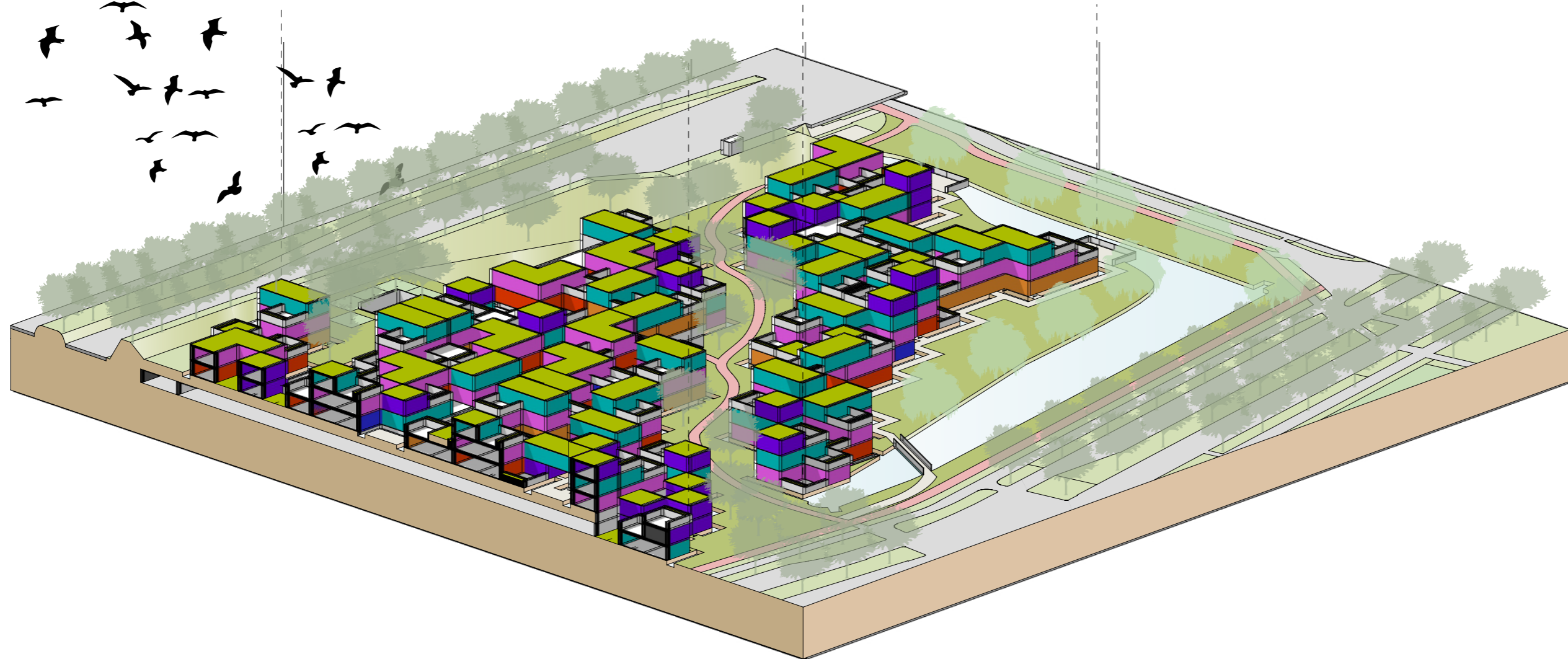

TERRASWONINGEN 2.0 AFRIKAWEG

STEFAN BROUWER, 2020

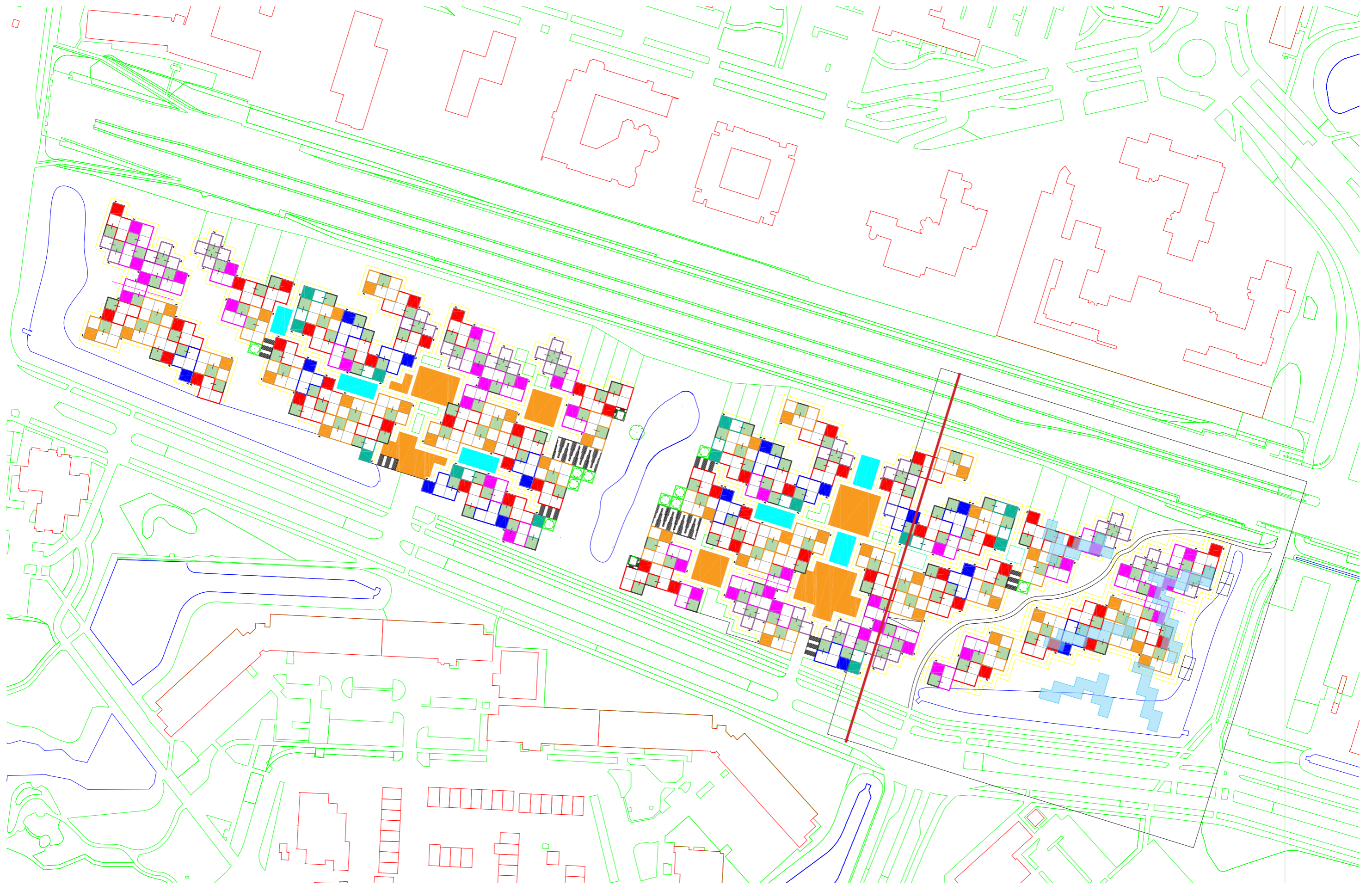

TERRASWONINGEN 2.0 AFRIKAWEG

STEFAN BROUWER, 2020

COLLECTIEVE RUIMTEN

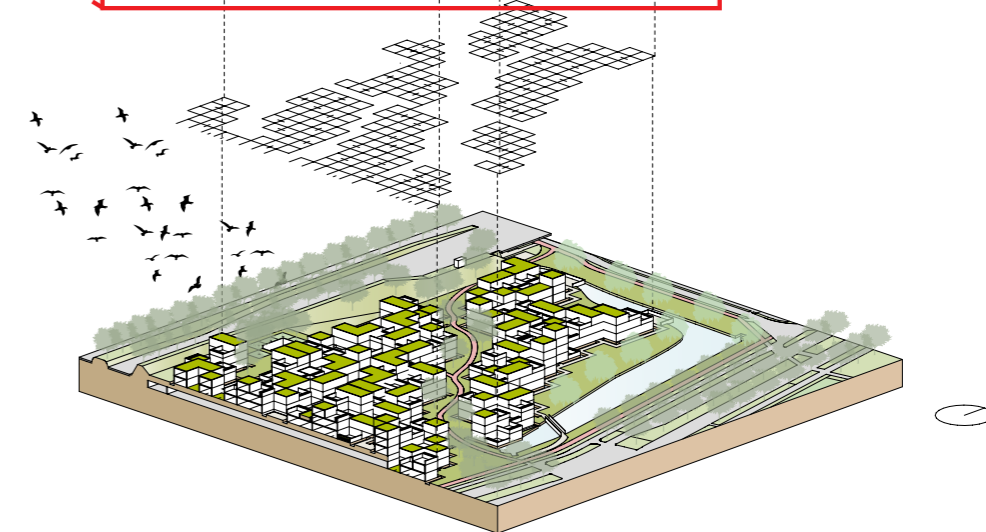
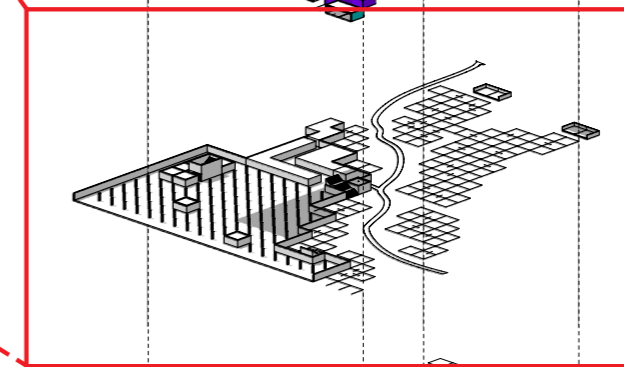
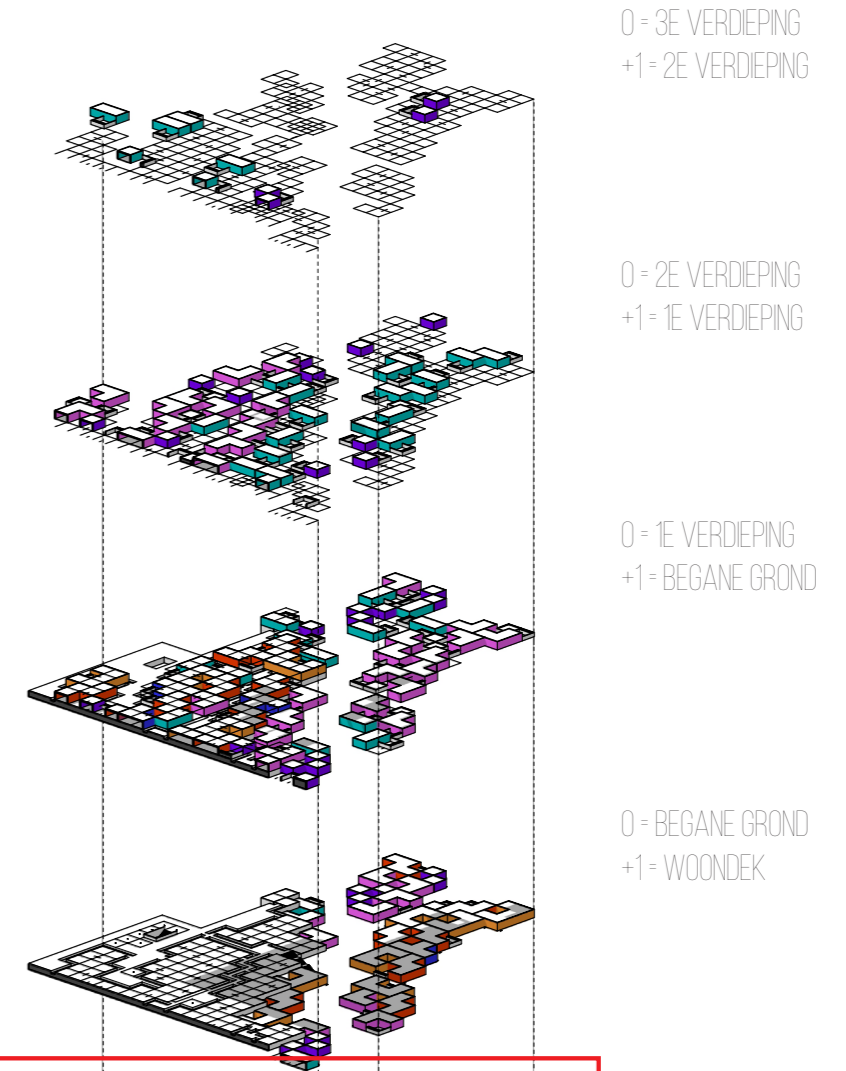
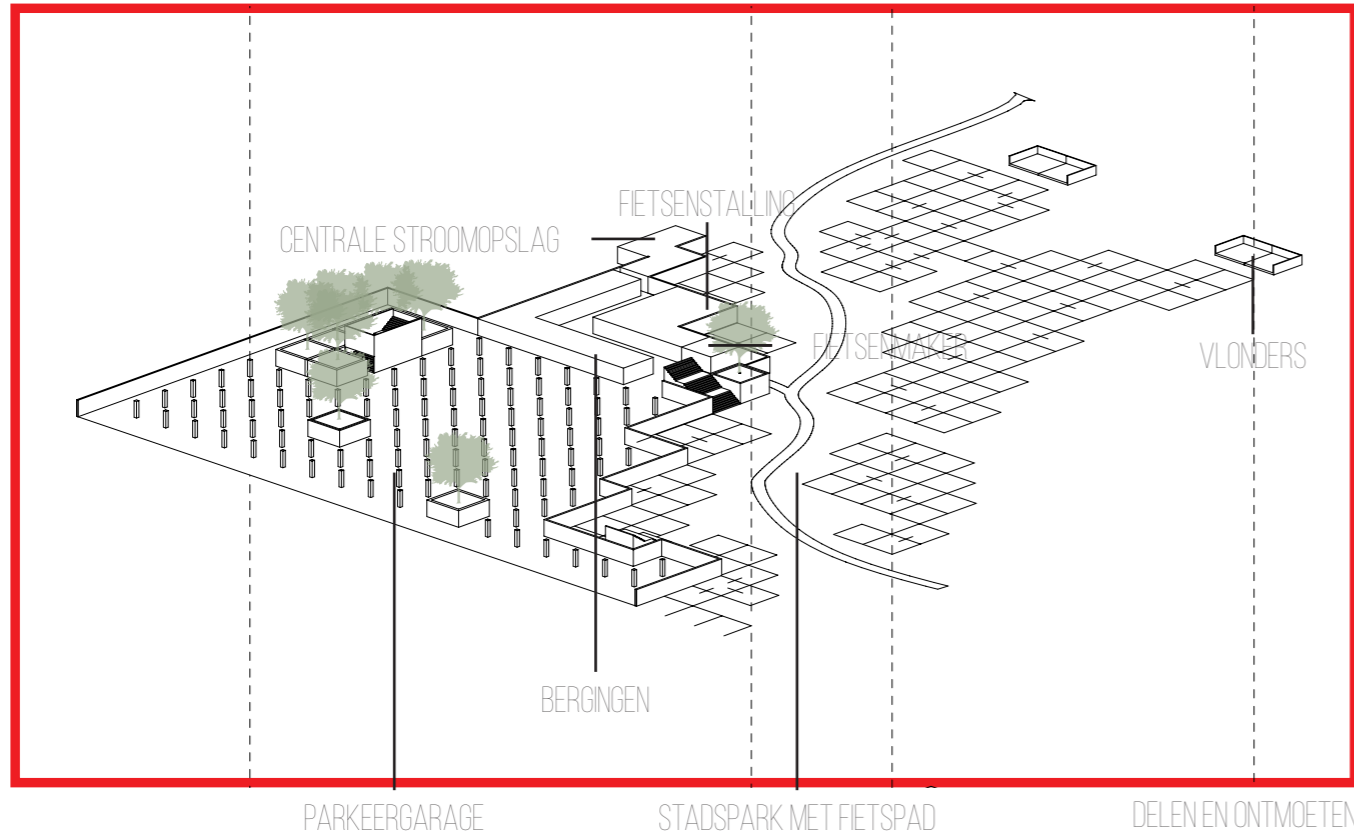

TERRASWONINGEN 2.0 AFRIKAWEG

STEFAN BROUWER, 2020

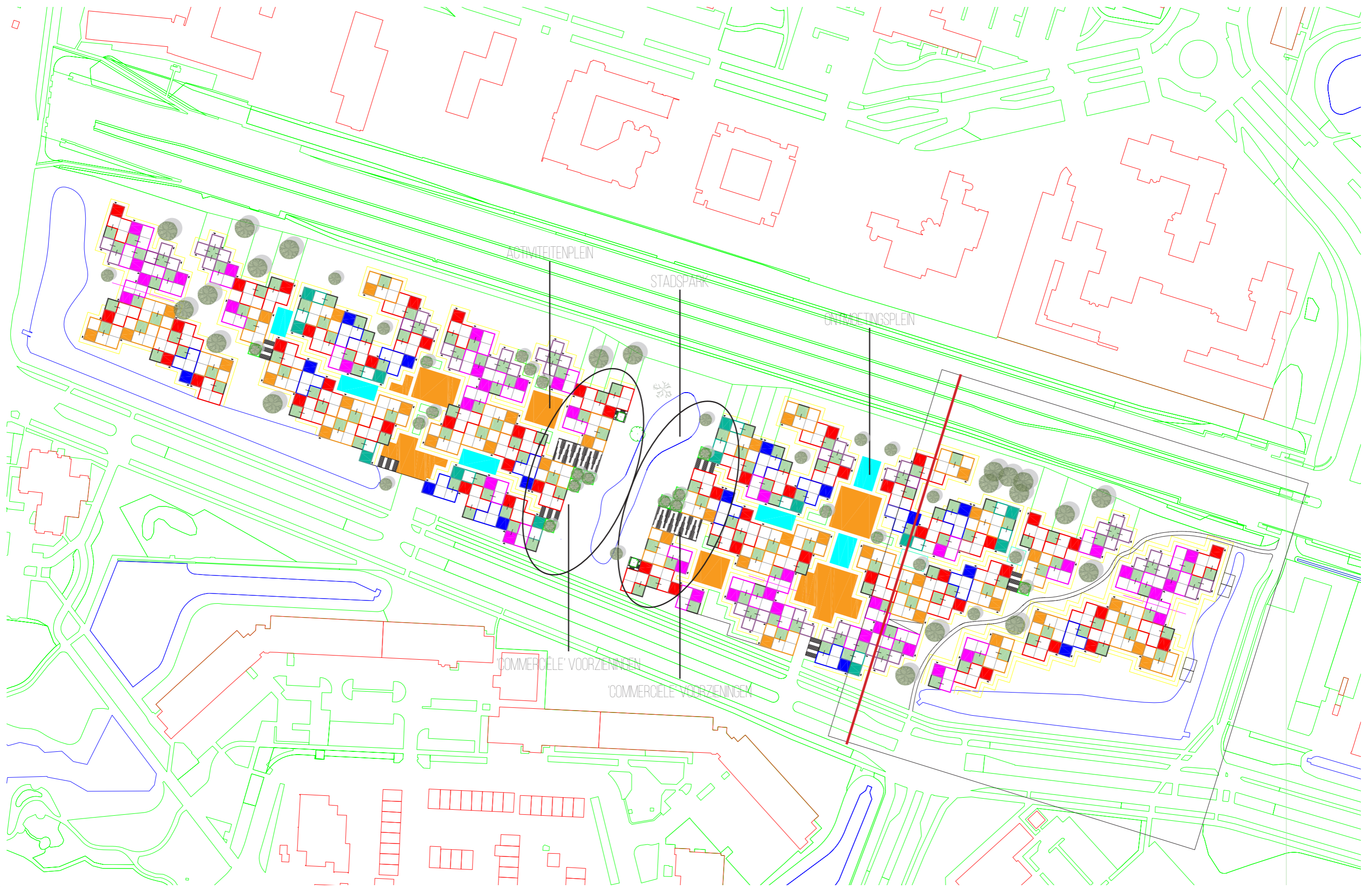

TERRASWONINGEN 2.0 AFRIKAWEG

STEFAN BROUWER, 2020

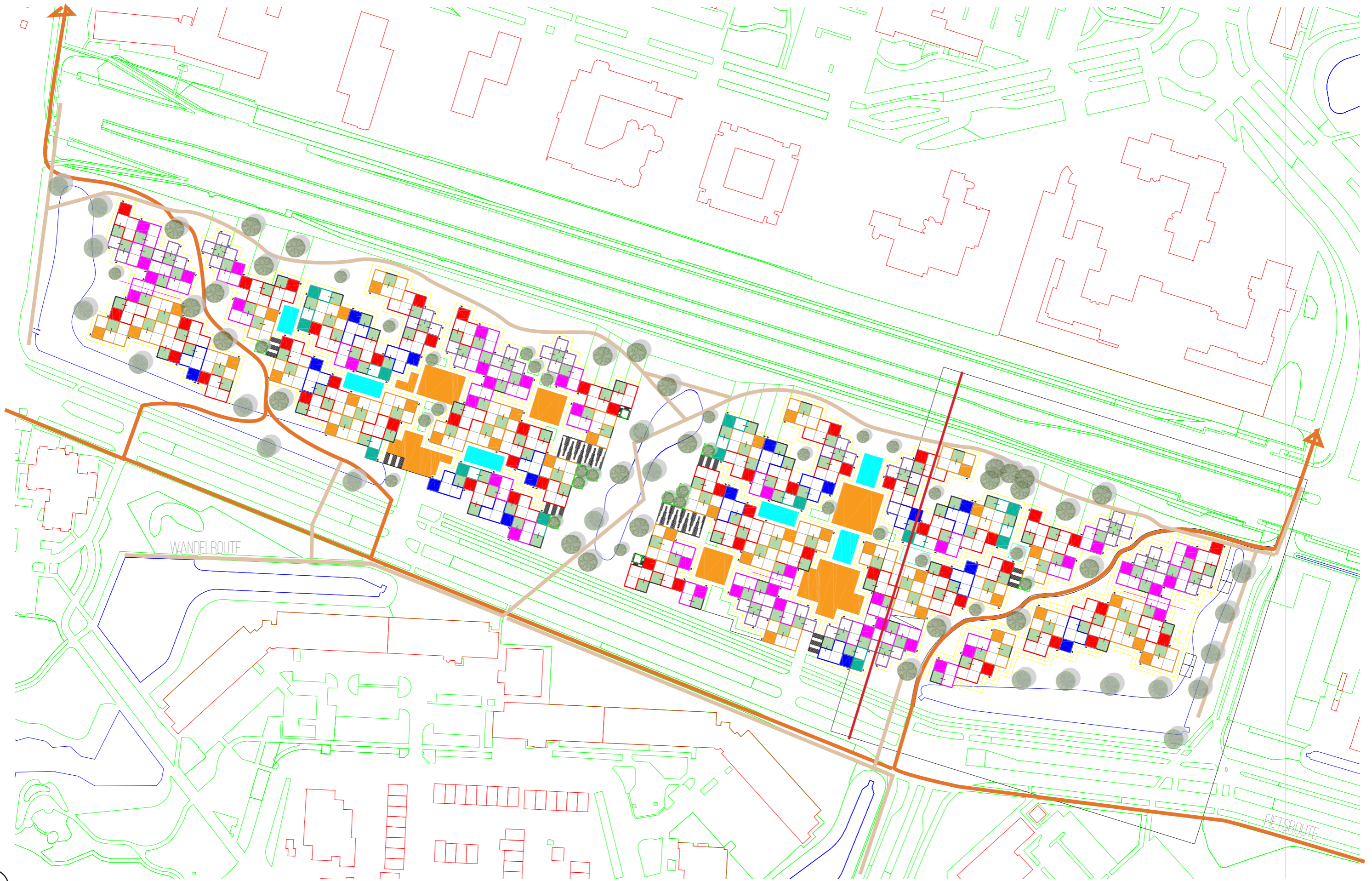

TERRASWONINGEN 2.0 AFRIKAWEG

STEFAN BROUWER, 2020

