

# embrace the city | love the port

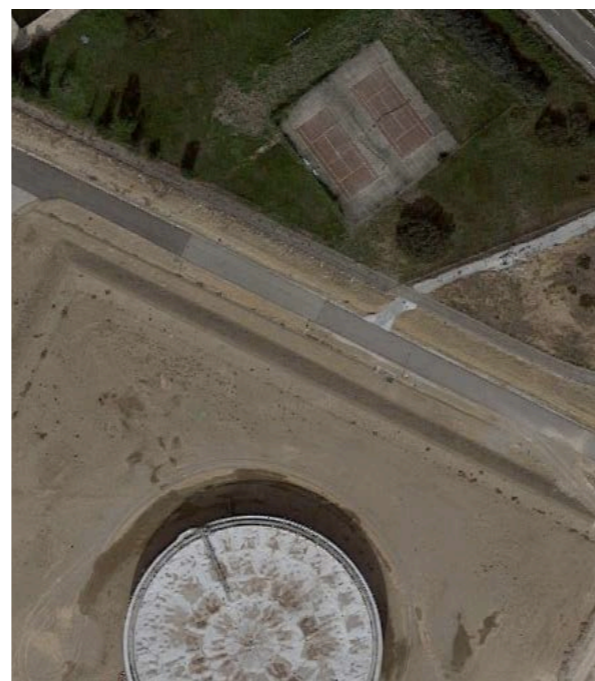

Martijn Feenstra

Rotterdamse Academie van Bouwkunst  
Harbour Studio: Rotterdam - Marseille - Fos

final presentation  
18 of June 2020

**manifesto**



*break through the disconnection of city and harbour*





*give back the shores to the city*





*activate the border zone through punctuation*





*use local typologies and existing spatial elements*





*showcase contrasts instead of ignoring them*





*create sustainable vibrant areas*



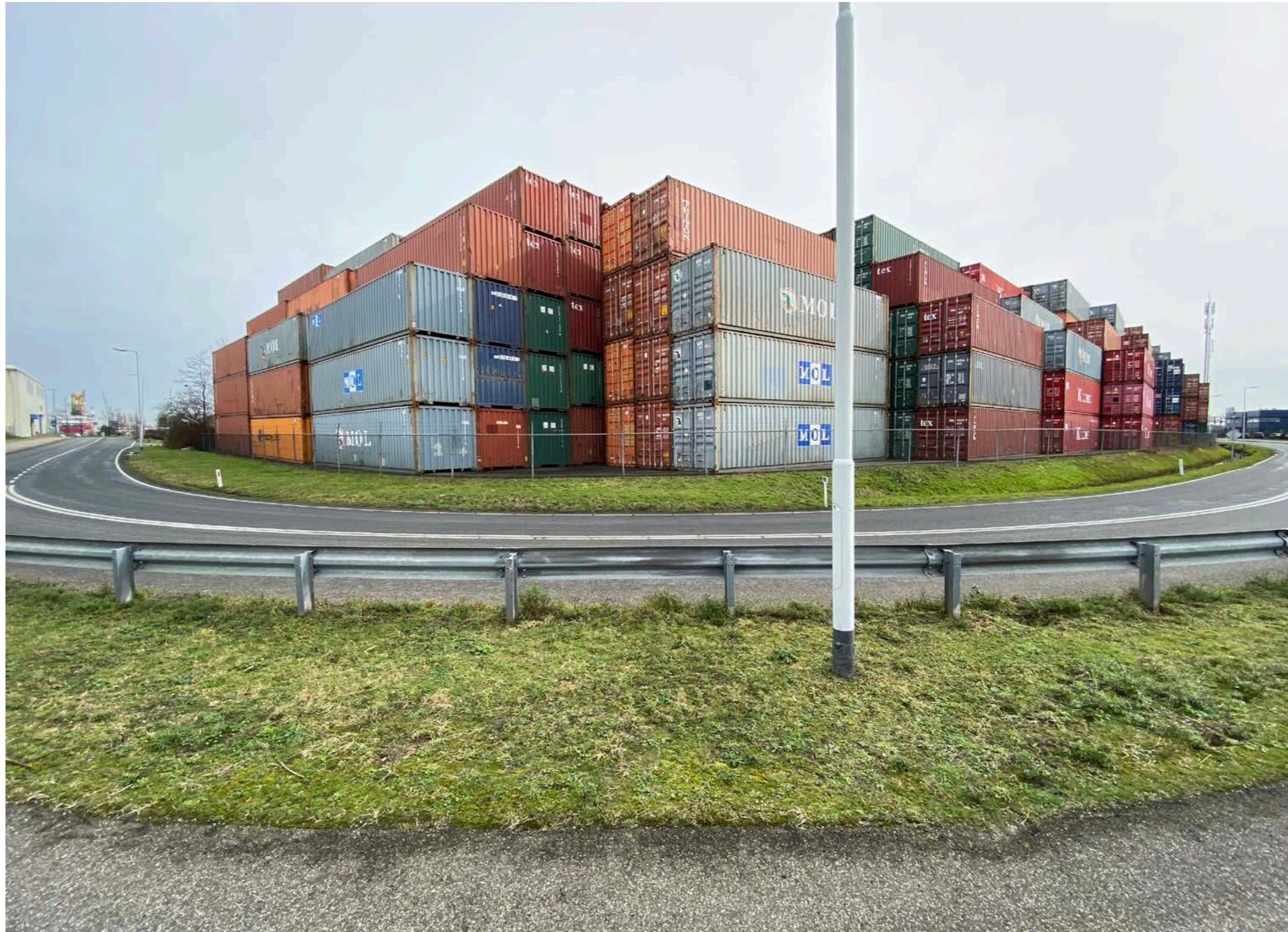

*surround the port with city-life*





*use soft transitions where needed*





*make it porous and increase liveability for city residents*



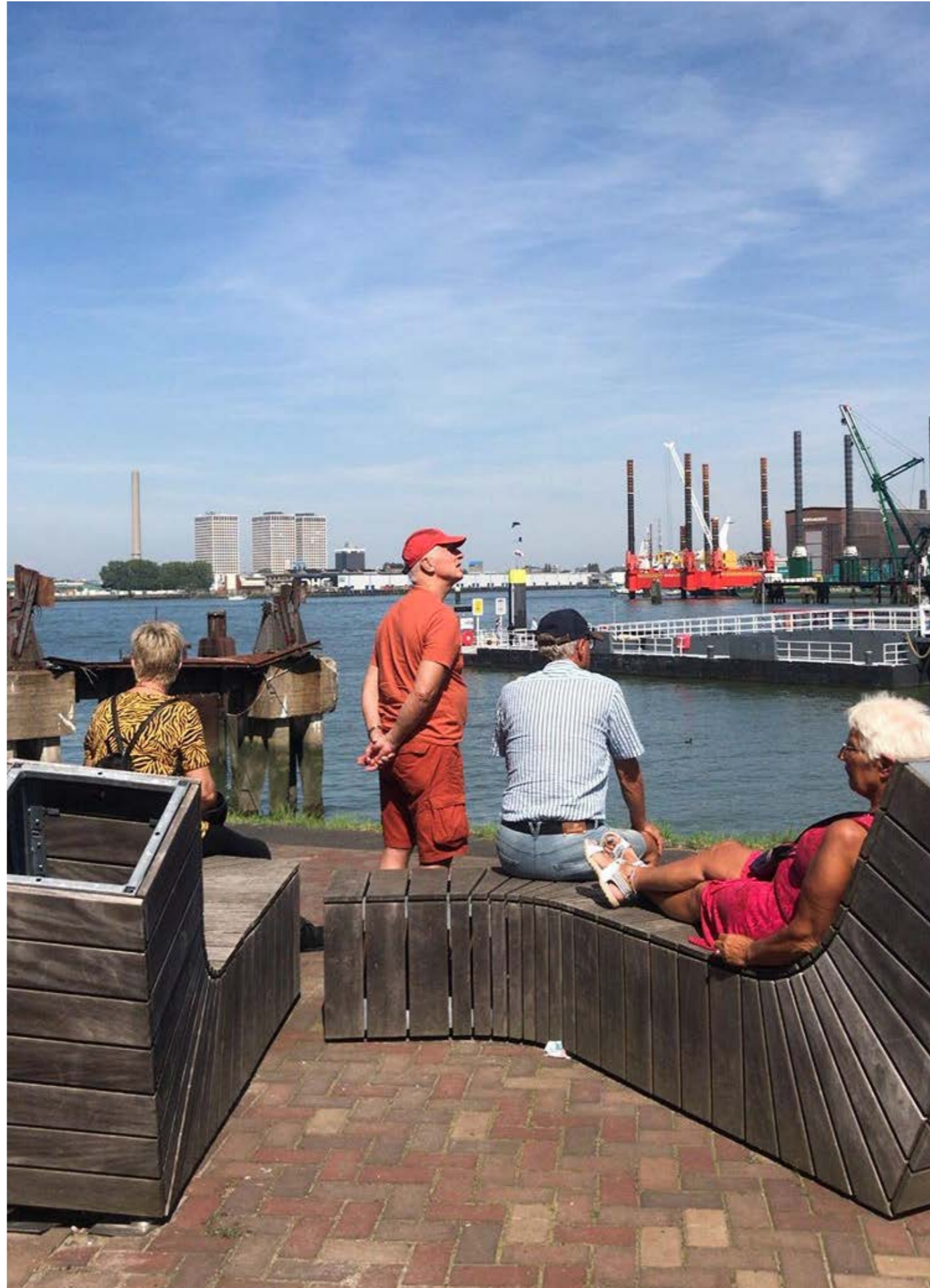

*love the city | embrace the port*



*break through the disconnection of city and harbour*

*give back the shores to the city*

*activate the border-zone through punctuation*

*use local typologies and existing spatial elements*

*showcase contrasts instead of ignoring them*

*create sustainable vibrant areas*

*surround the port with city-life*

*use soft transitions where needed*

*make it porous and increase liveability for city residents*

*love the city | embrace the port*



**fascination and research**



# fascination

## harbour landscapes



*refinery*



*solid bulk - iron*



*pleasure*



*viewing point*



*petrochemical storage*

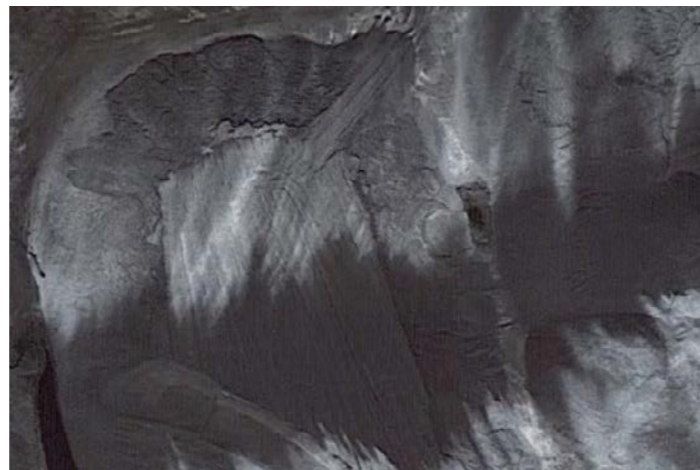

*coal (coal fired power station)*

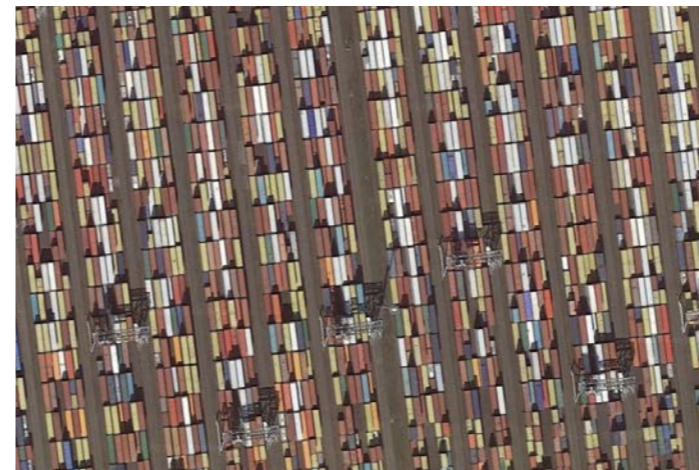

*shipping containers*



*car industry*

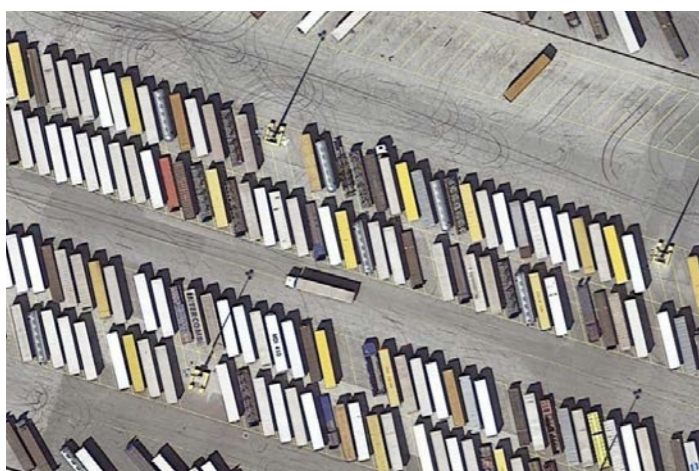

*semitrailers*

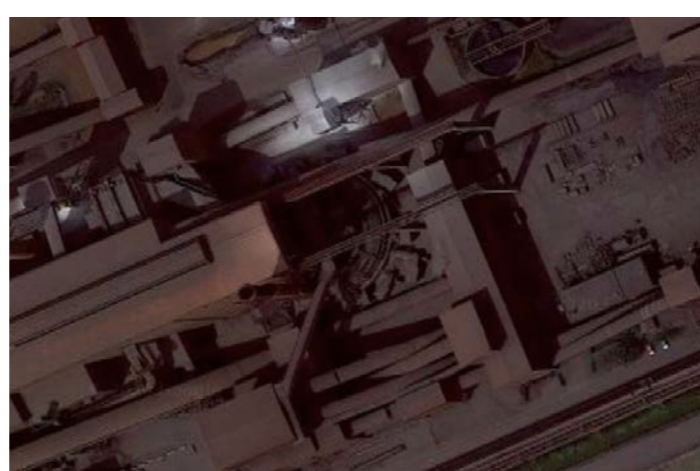

*blast furnace*

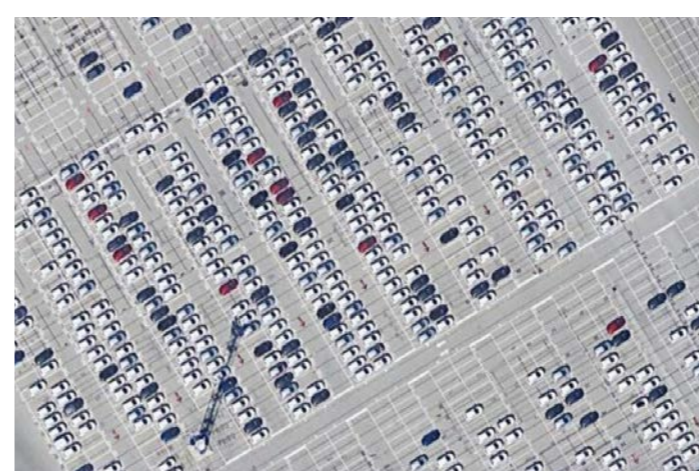

*car industry*



*pleasure crafts*



# fascination

accumulation | Rotterdam

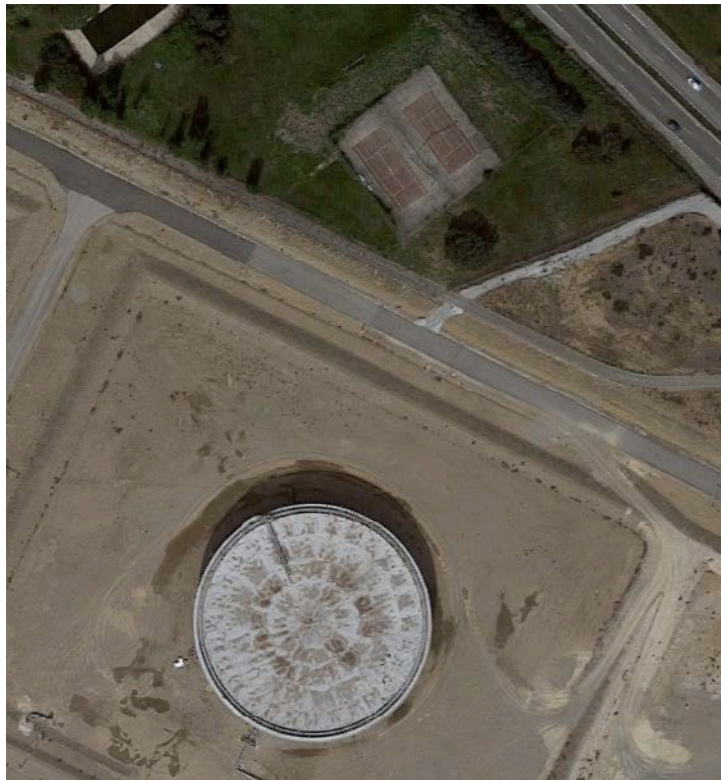
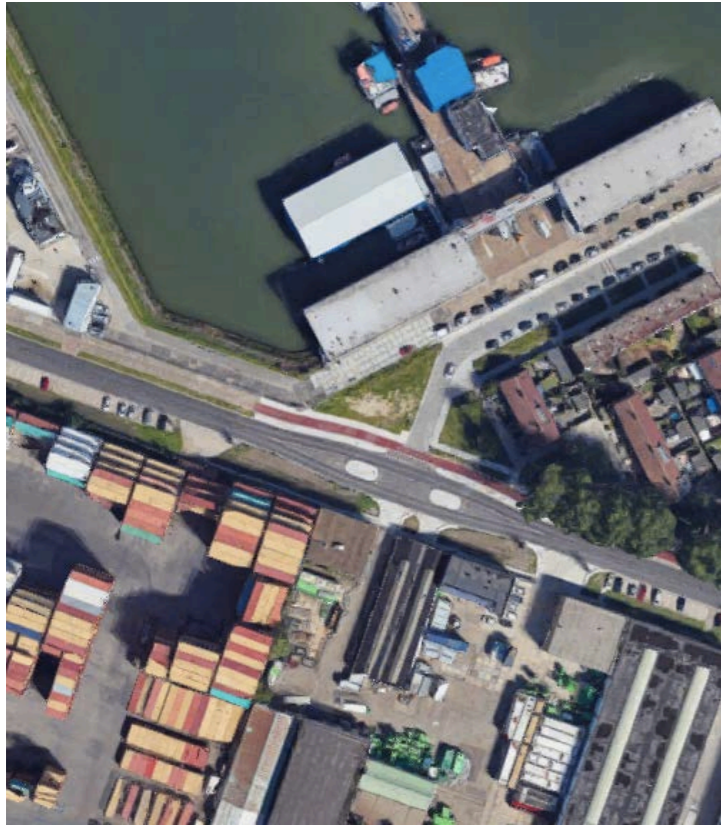



# research

## accumulations

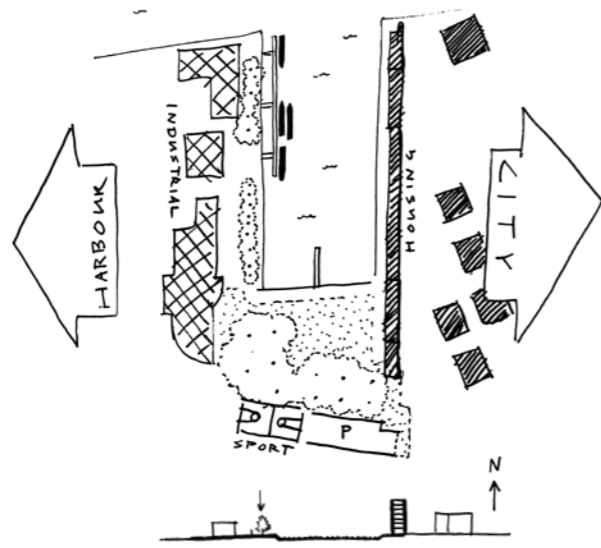

Charlois

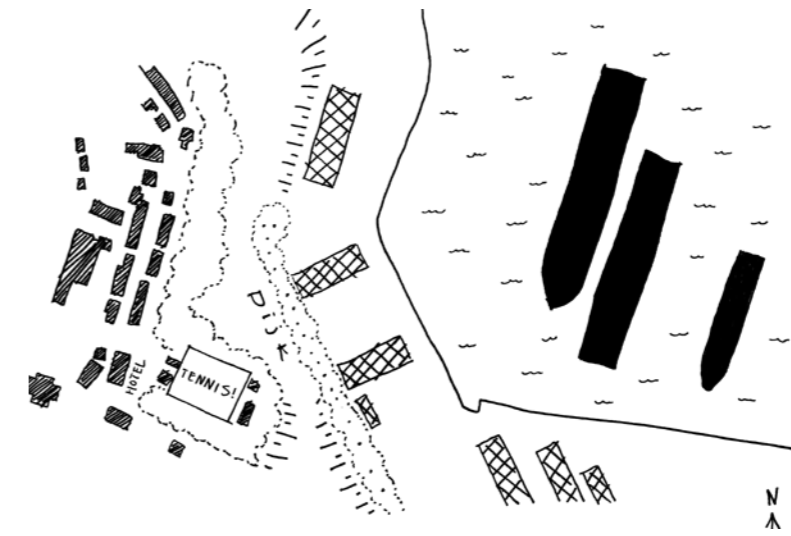

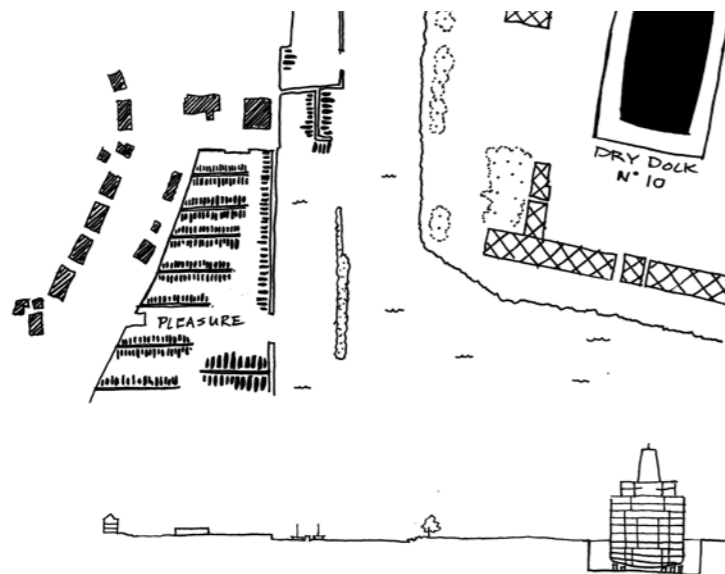

Pernis

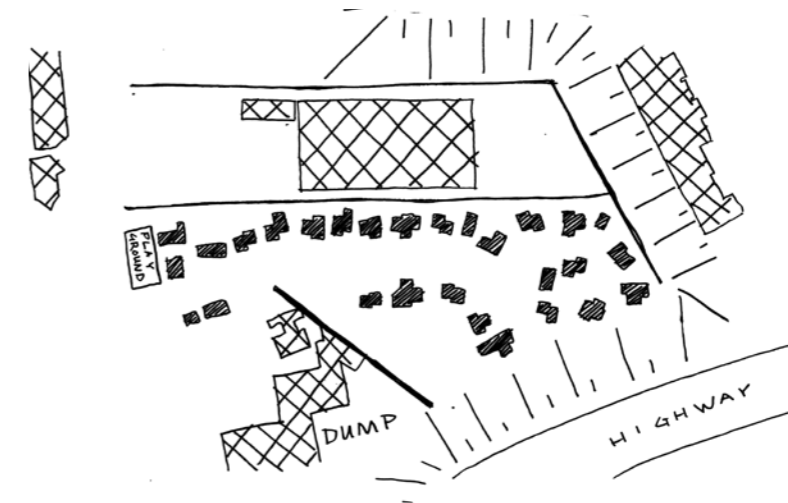

l'Estaque



Saint-André

-  housing
-  harbour functions



**drench the harbours in humanity**



**locations**

# locations

## historic parallels

*Waalhaven*



1947



1947  
high activity edge

*Le Bassin de la Grande Joliette*



1932



1932  
high activity edge



# locations

## current parallels

*Waalhaven*



2020  
low activity edge

*Le Bassin de la Grande Joliette*



2020  
low activity edge



“We’ve been coming here since I was very young. I lived very close actually. The scenery always changes but the feeling is still the same.”

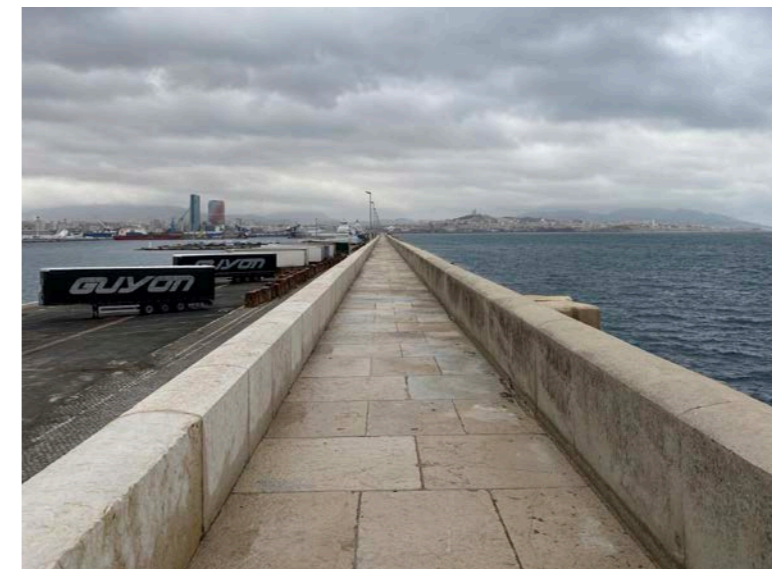

“I have memories, when before, we could come here and walk on the sea wall. When we could see on the one side the this fantastic harbour and on the other this fantastic city with its liveliness and live”



# locations

learning from each other

*Waalhaven*

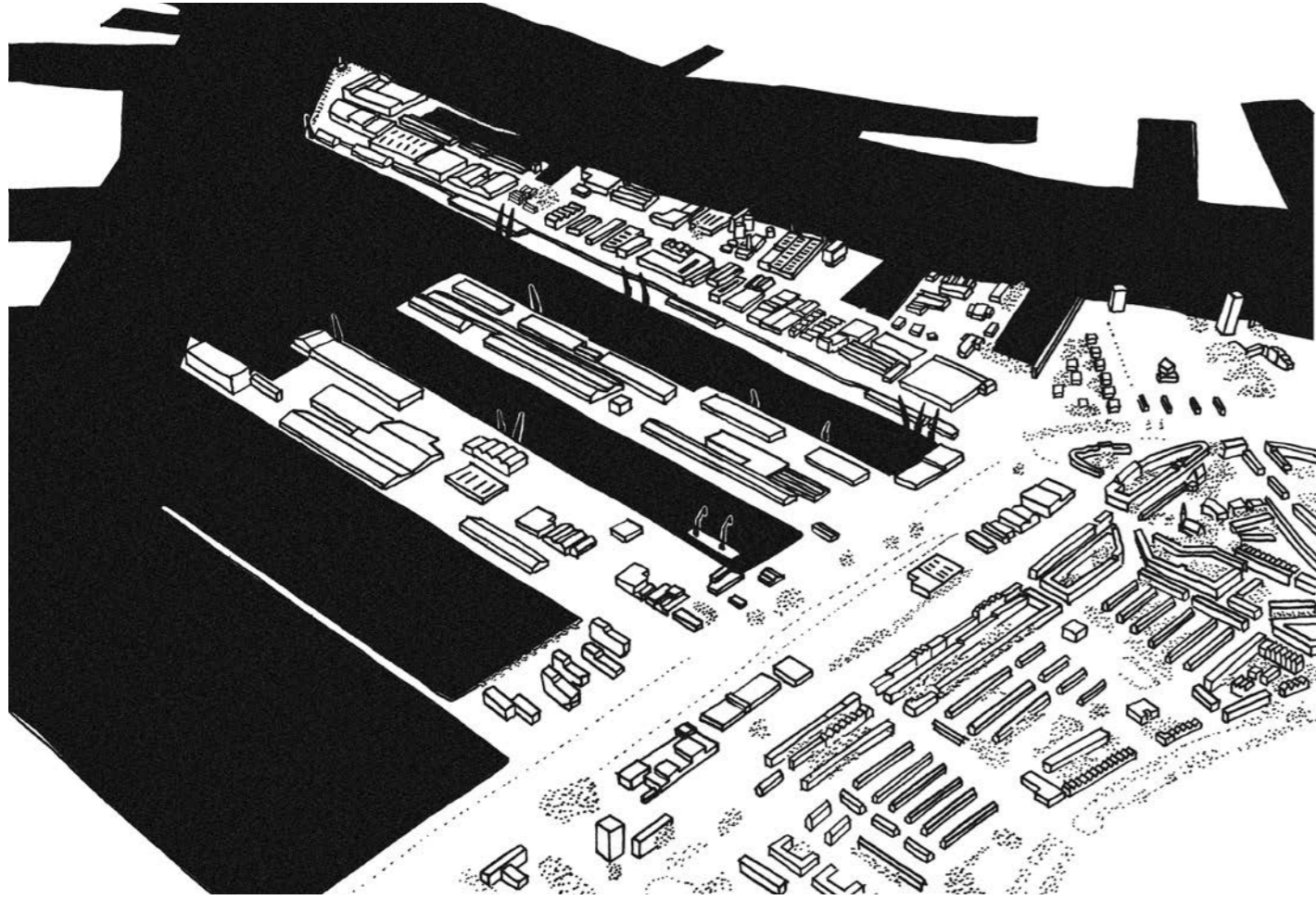

Learning from Marseille

*Le Bassin de la Grande Joliette*

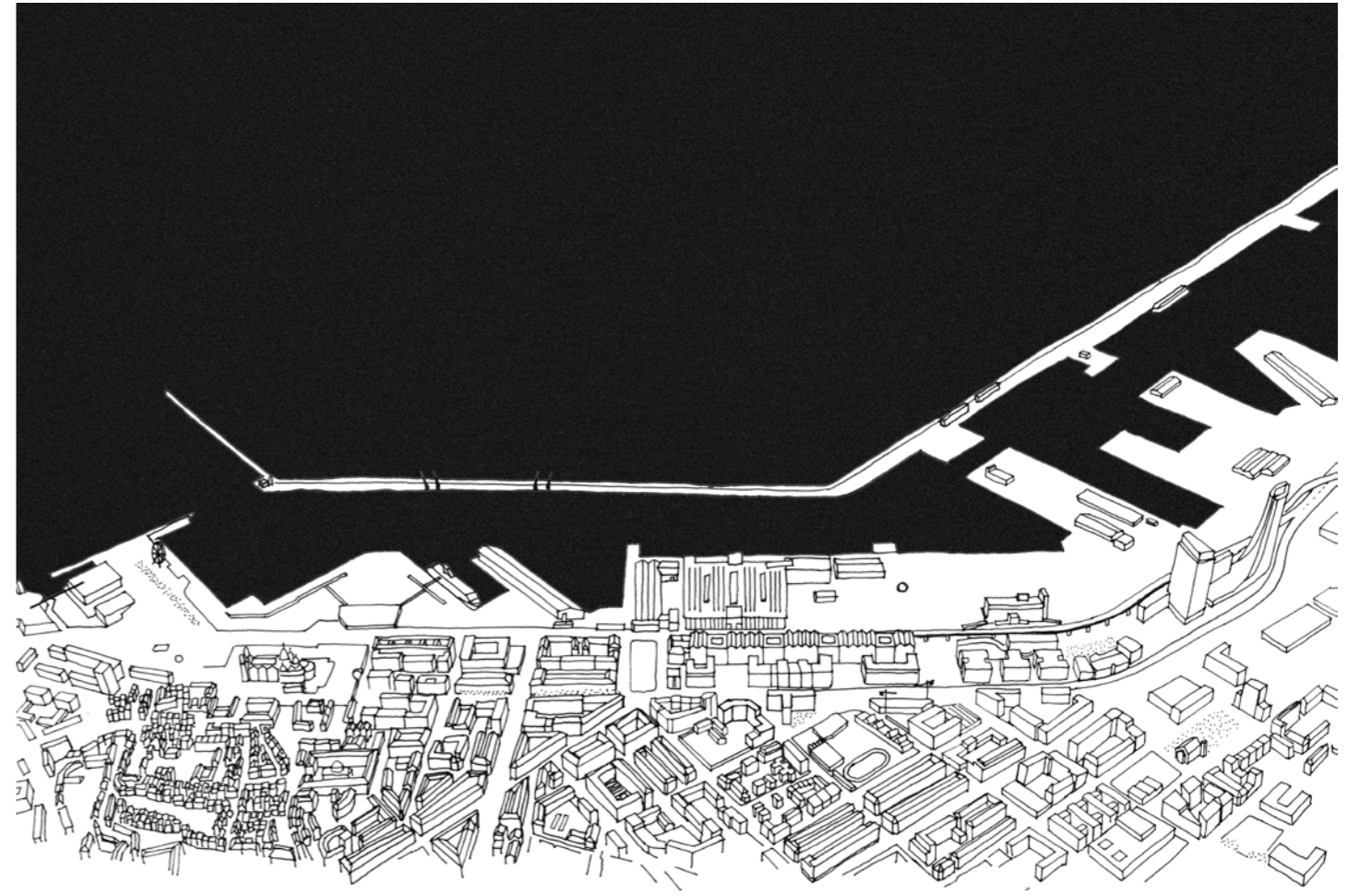

Learning from Rotterdam



# locations

comparison - waterline

*Waalhaven*

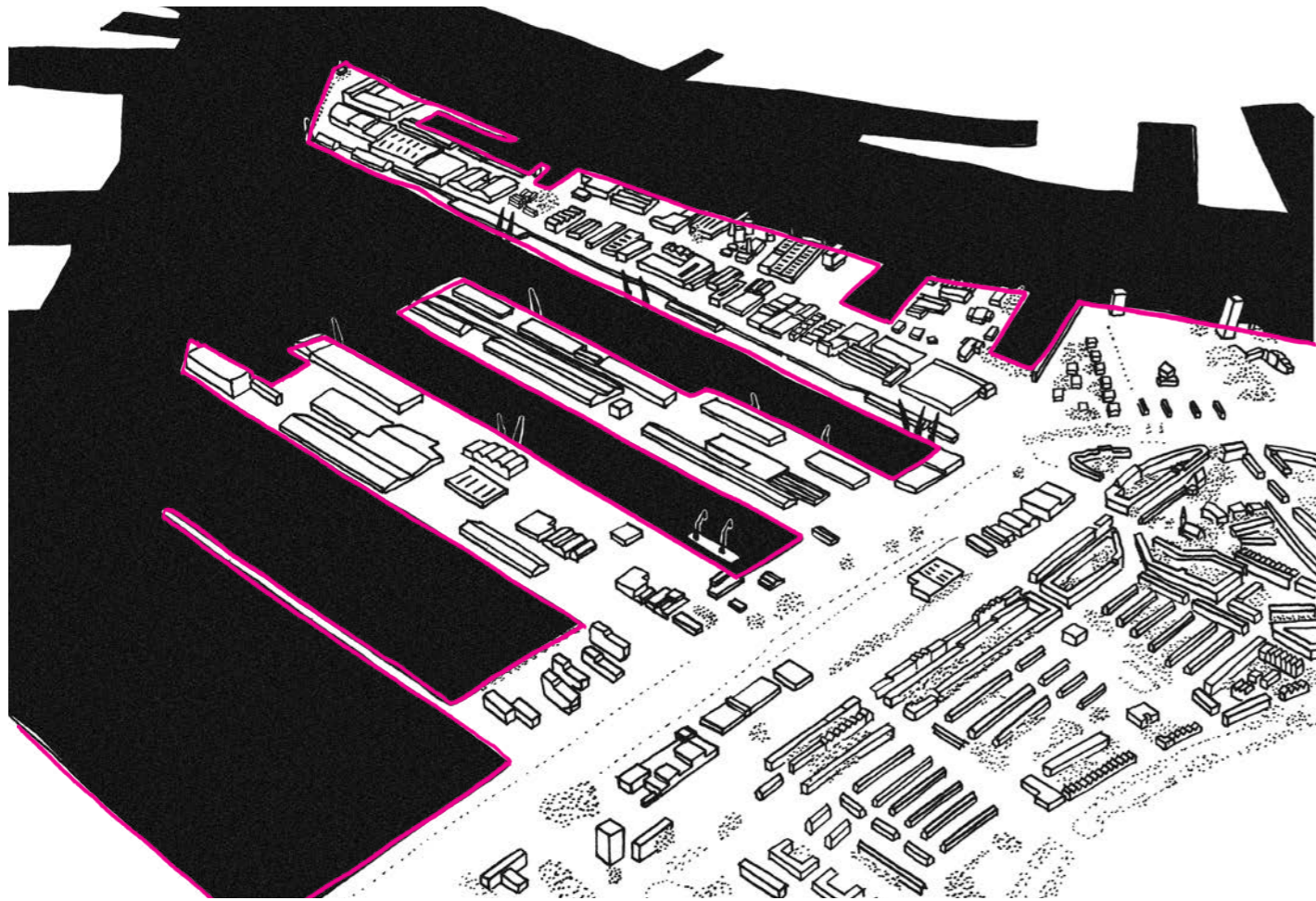

three-part harbour area

*Le Bassin de la Grande Joliette*

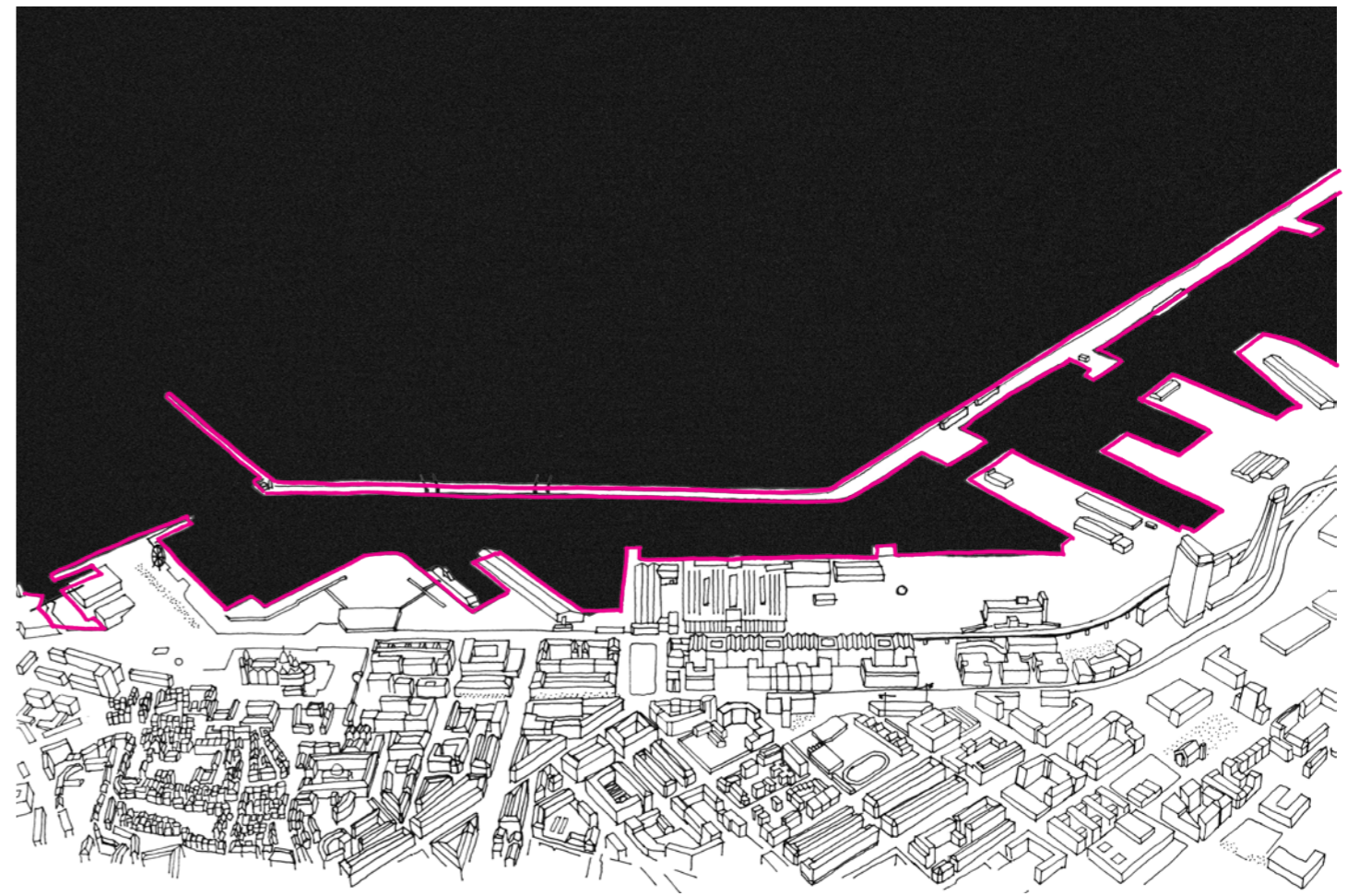

one-parted harbour area



# locations

## comparison - harbour functions

*Waalhaven*

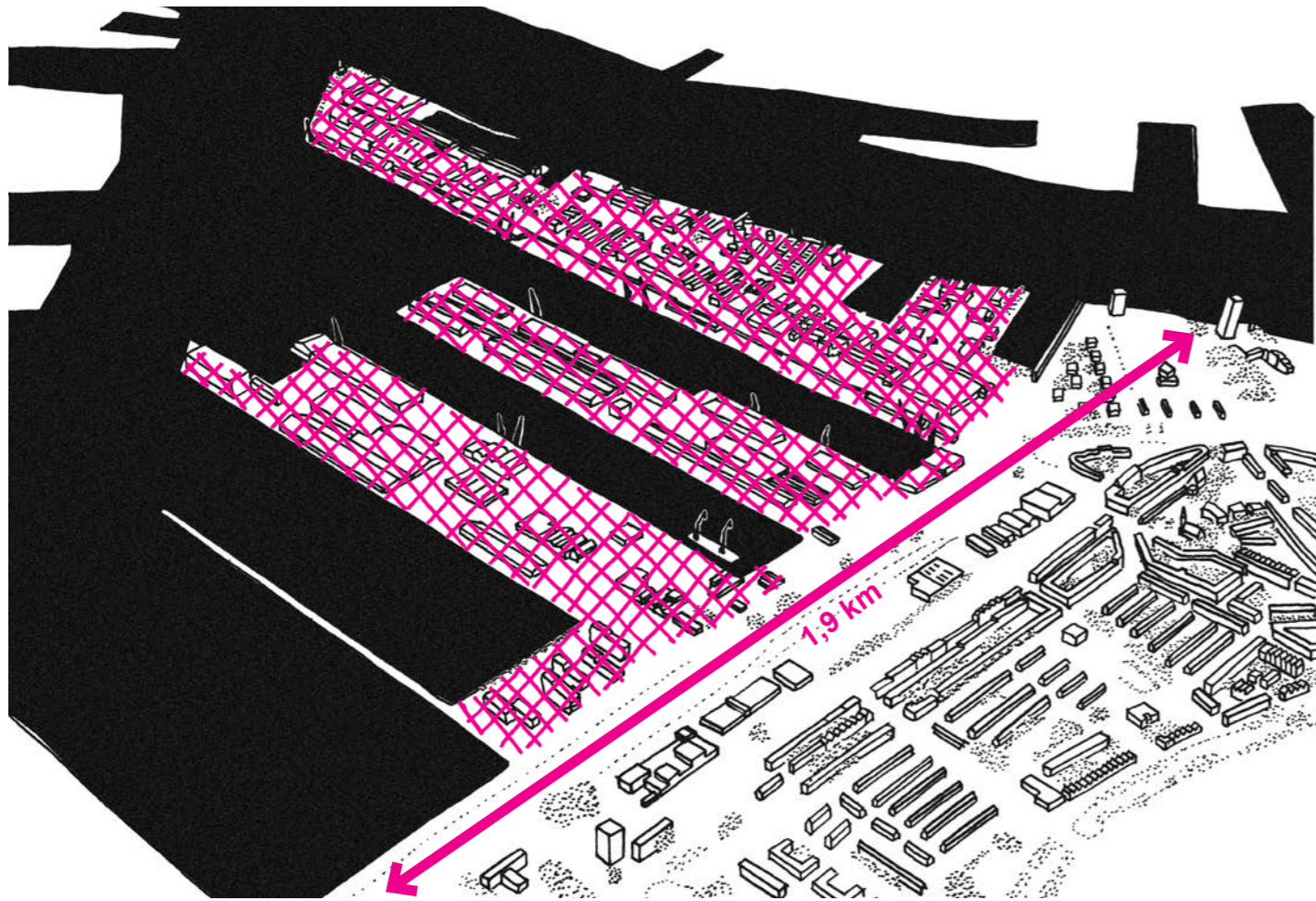

harbour functions are scattered along the edge

*Le Bassin de la Grande Joliette*

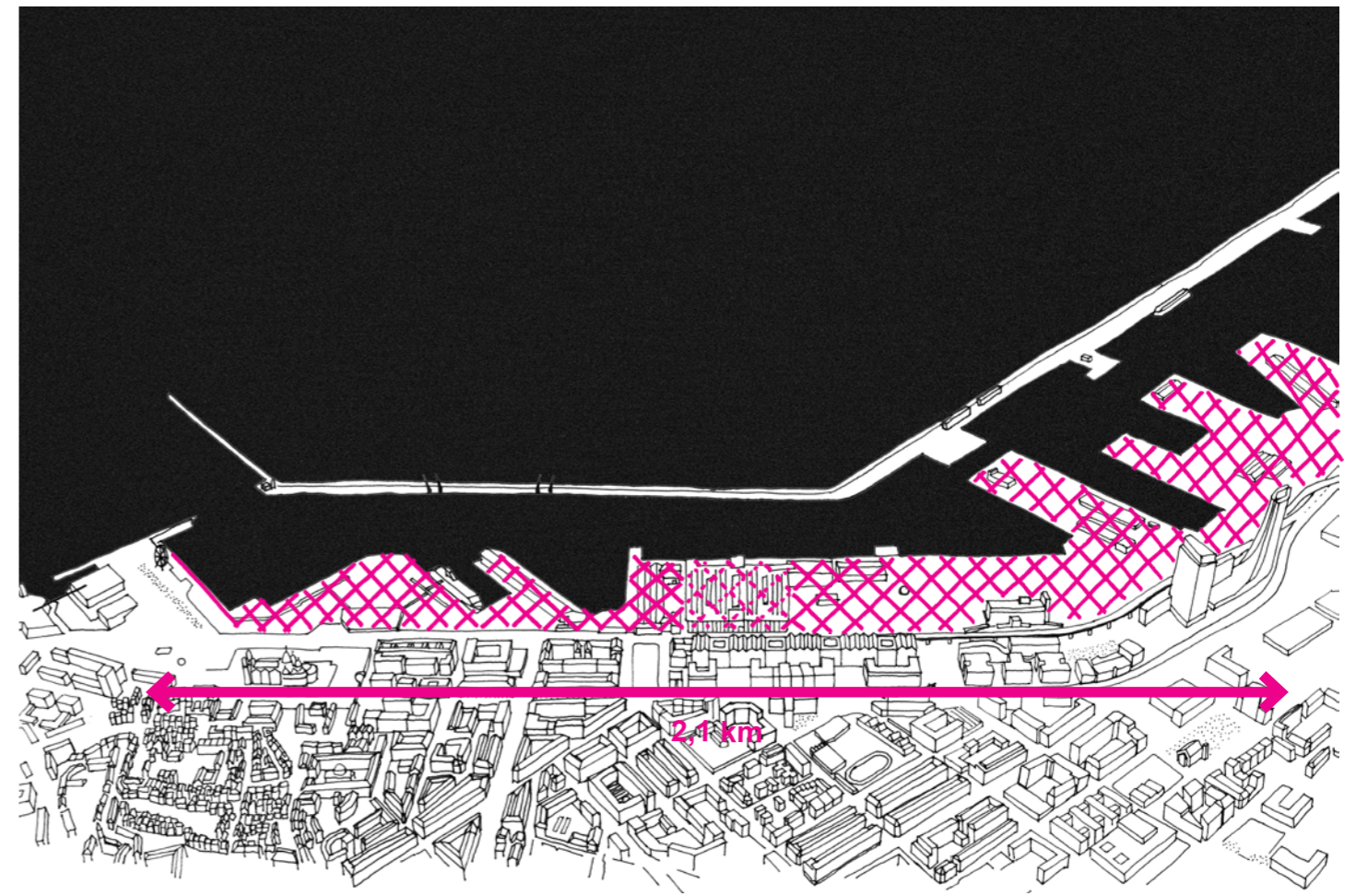

harbour functions take a uniform shape along the edge



# locations

## comparison - accessibility

*Waalhaven*

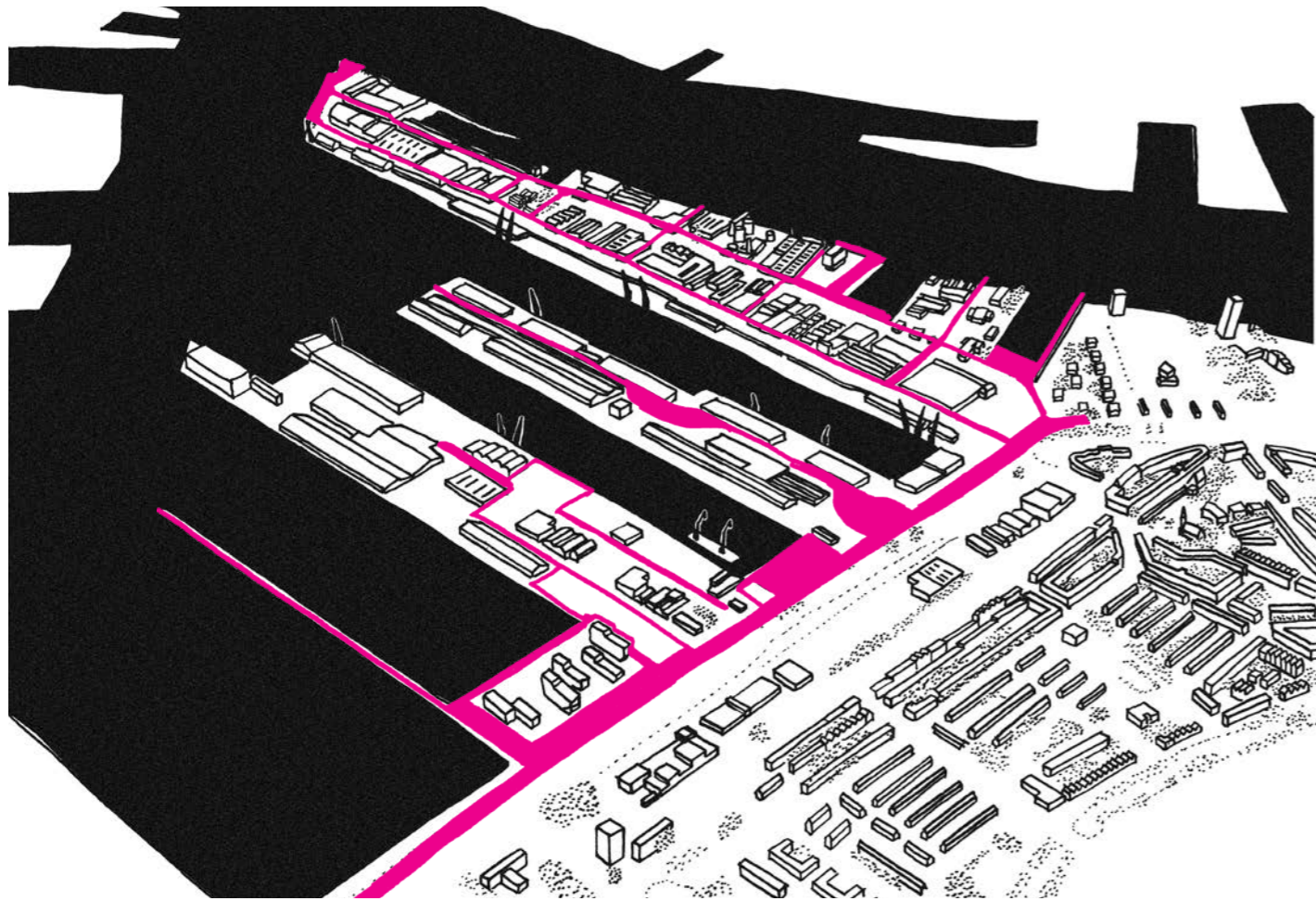

high accessibility in industrial area

*Le Bassin de la Grande Joliette*

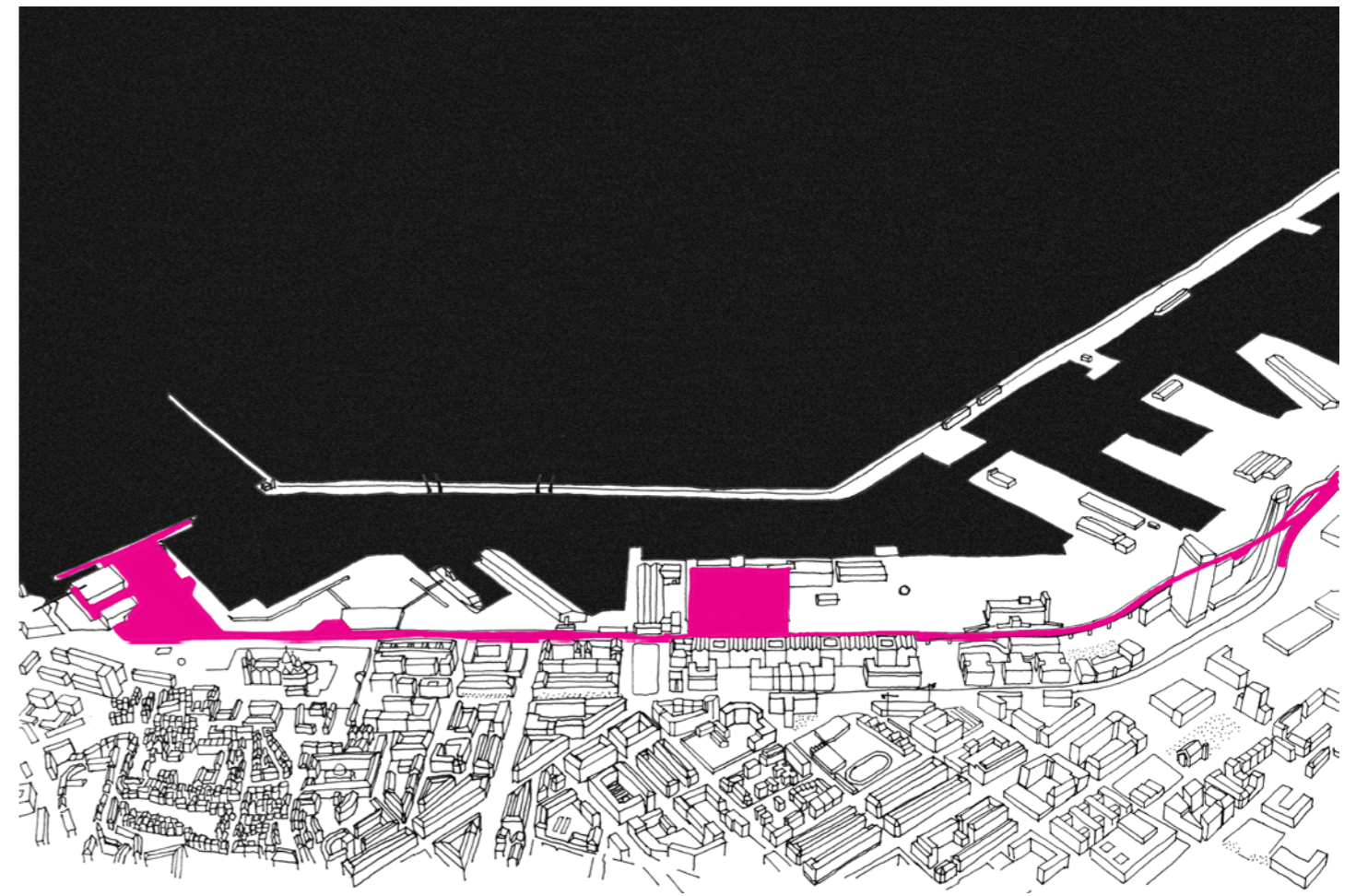

accessibility in harbour area is non-existent



# locations

## comparison - green areas

*Waalhaven*

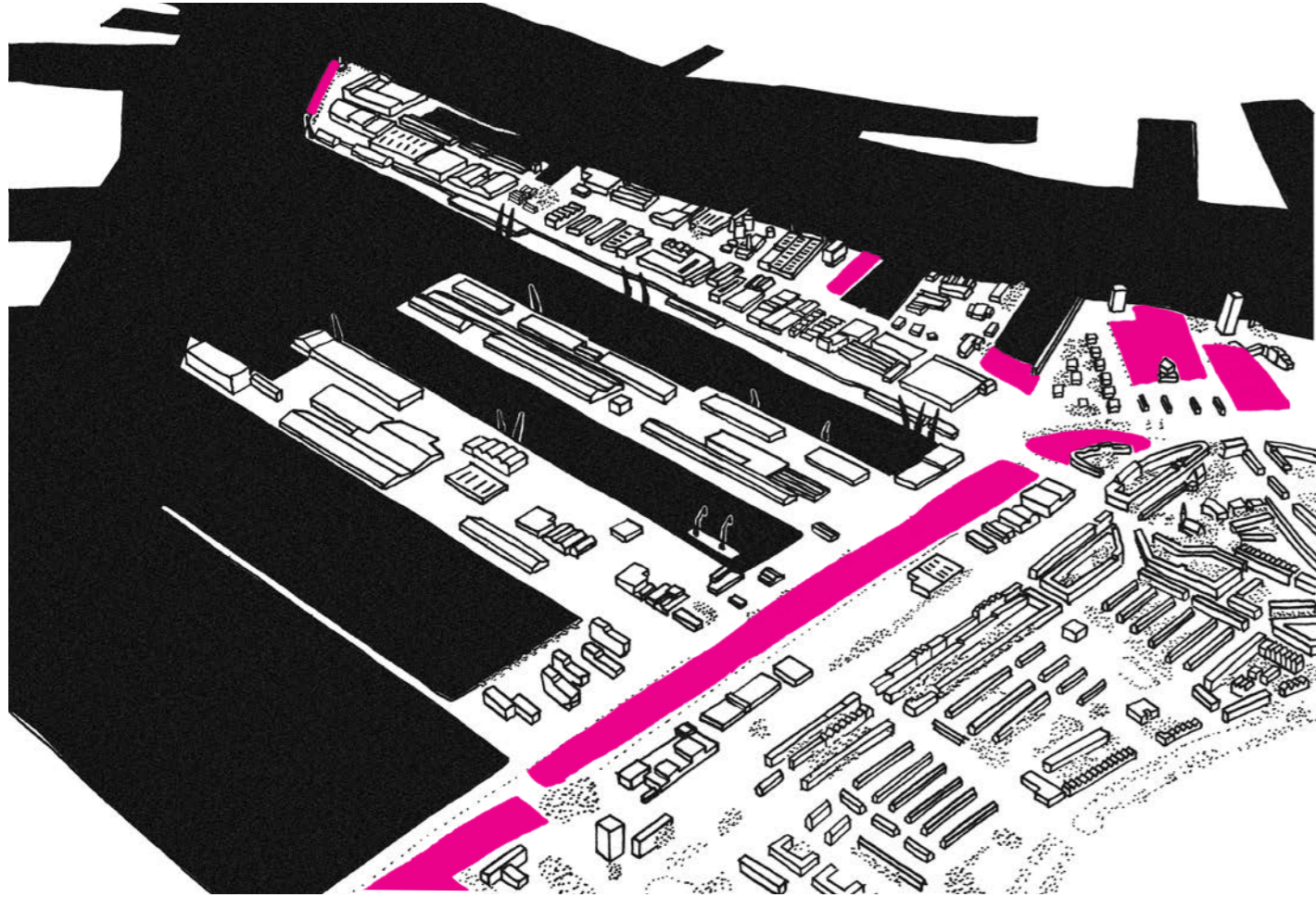

large number of patches of green accomodating leisure

*Le Bassin de la Grande Joliette*

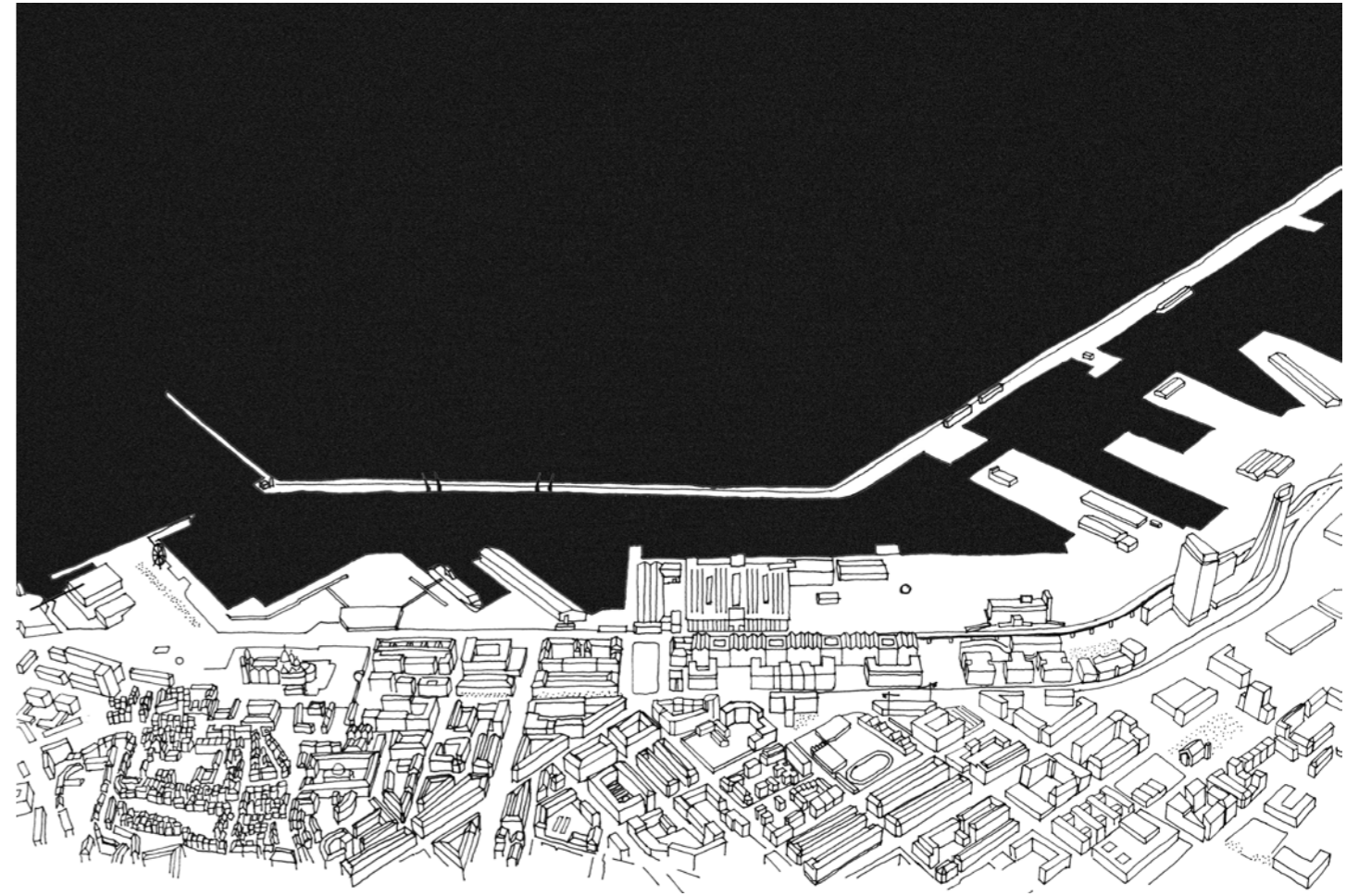

just a small strip of non-usable green



# locations

## comparison - public facilities

*Waalhaven*

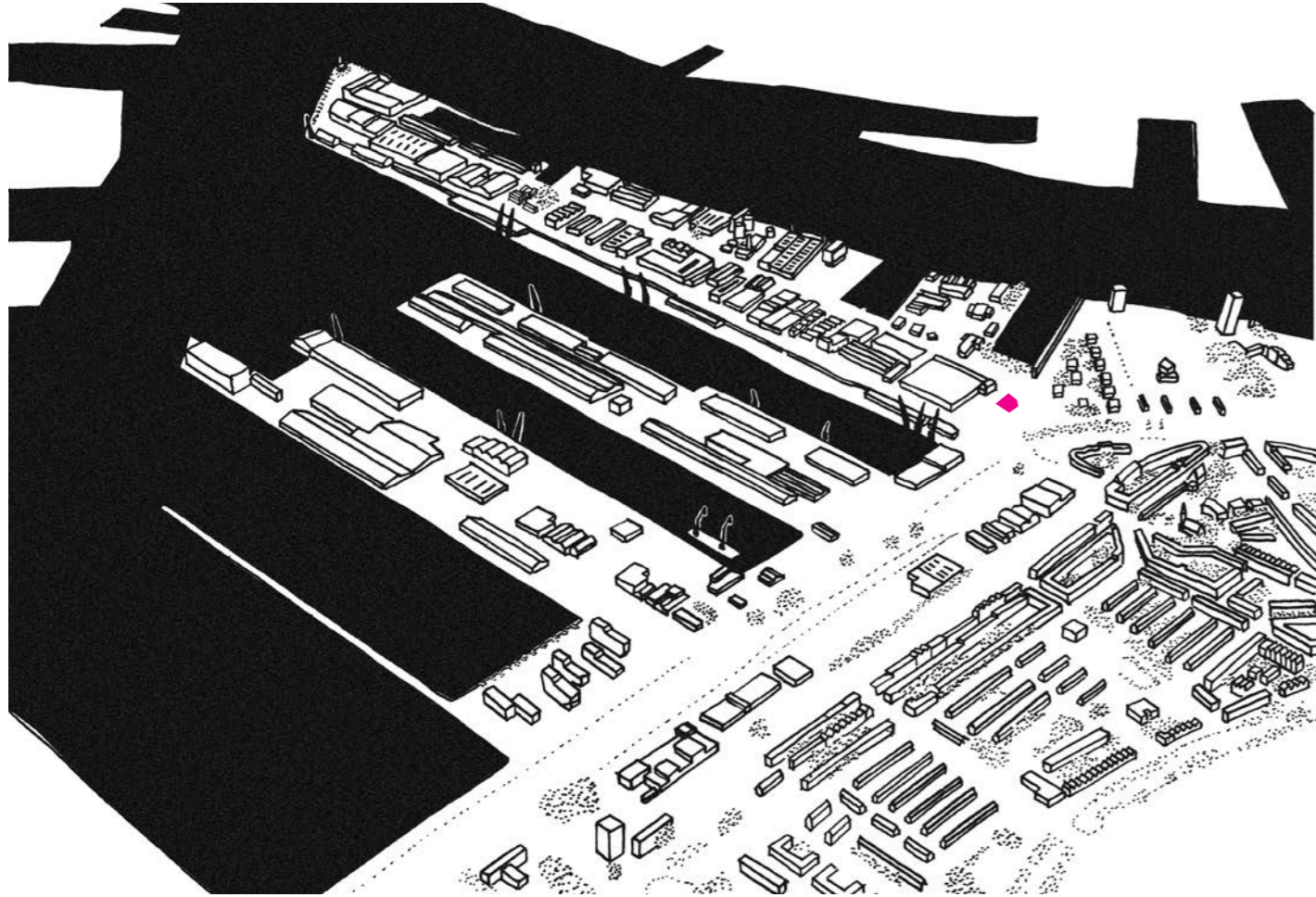

Little to none public facilities in the area

*Le Bassin de la Grande Joliette*

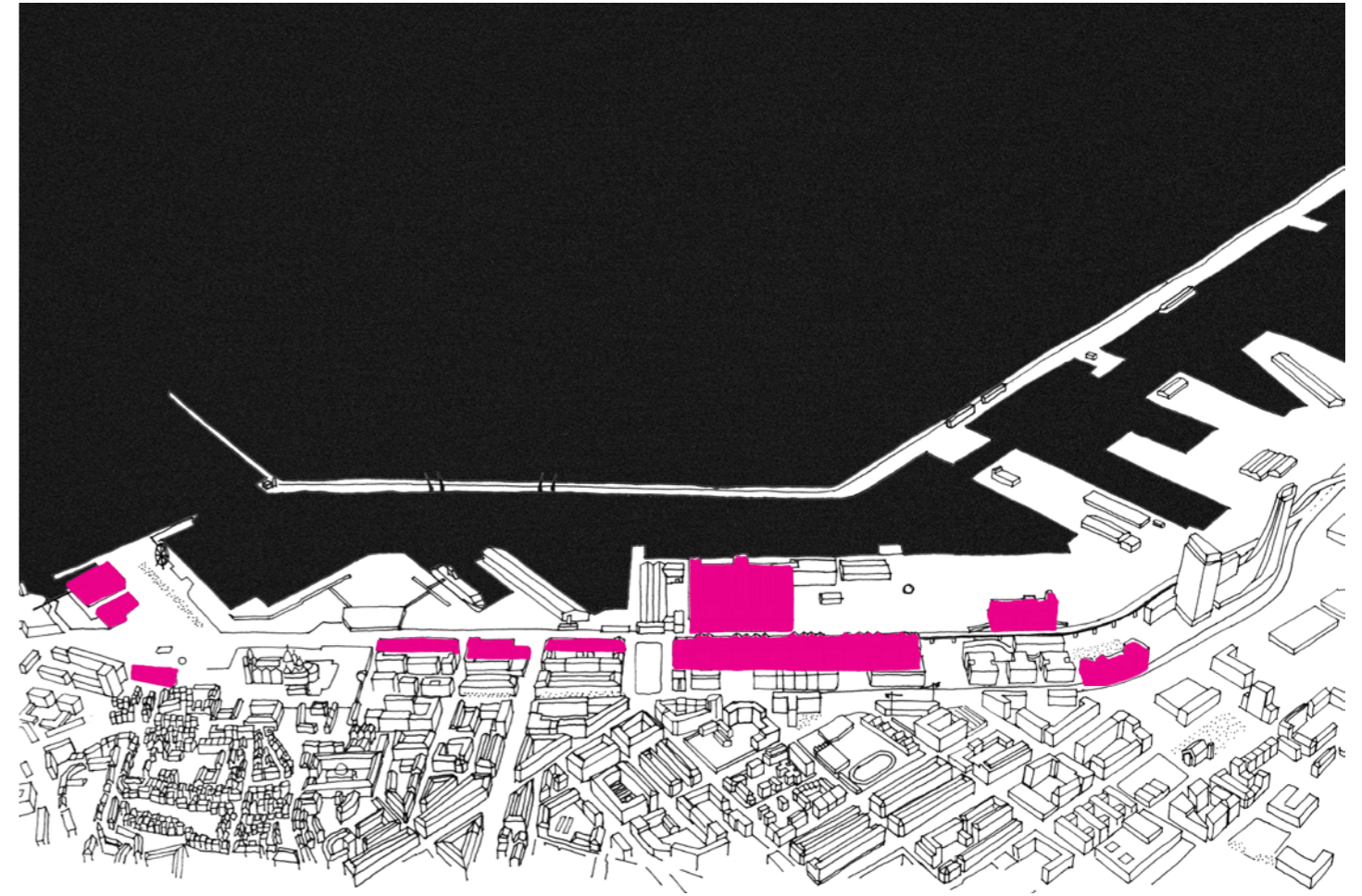



# locations

## actions

### *Waalhaven*

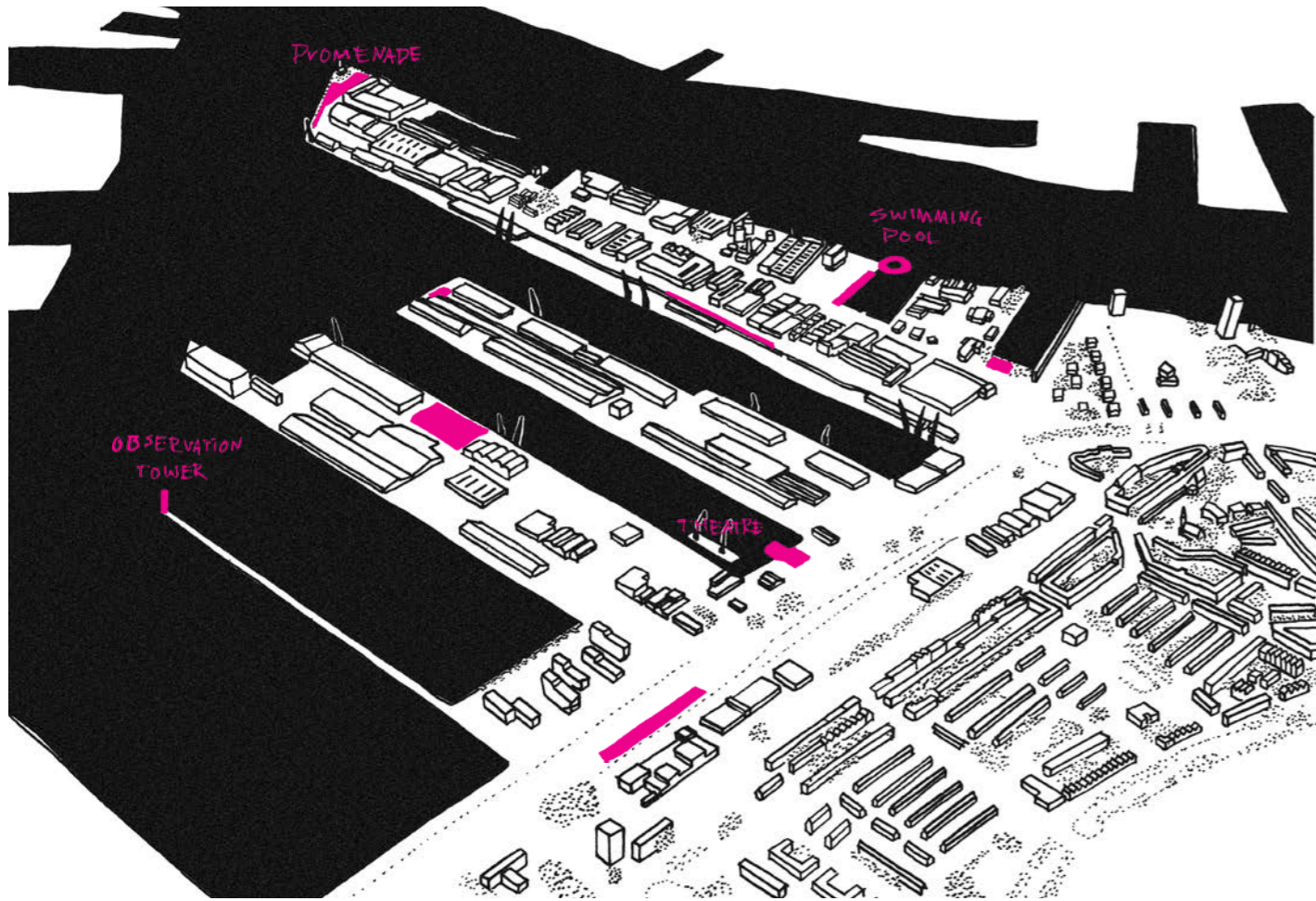

focus on existing spatial elements

add public functions

create motivations to go into the area

### *Le Bassin de la Grande Joliette*

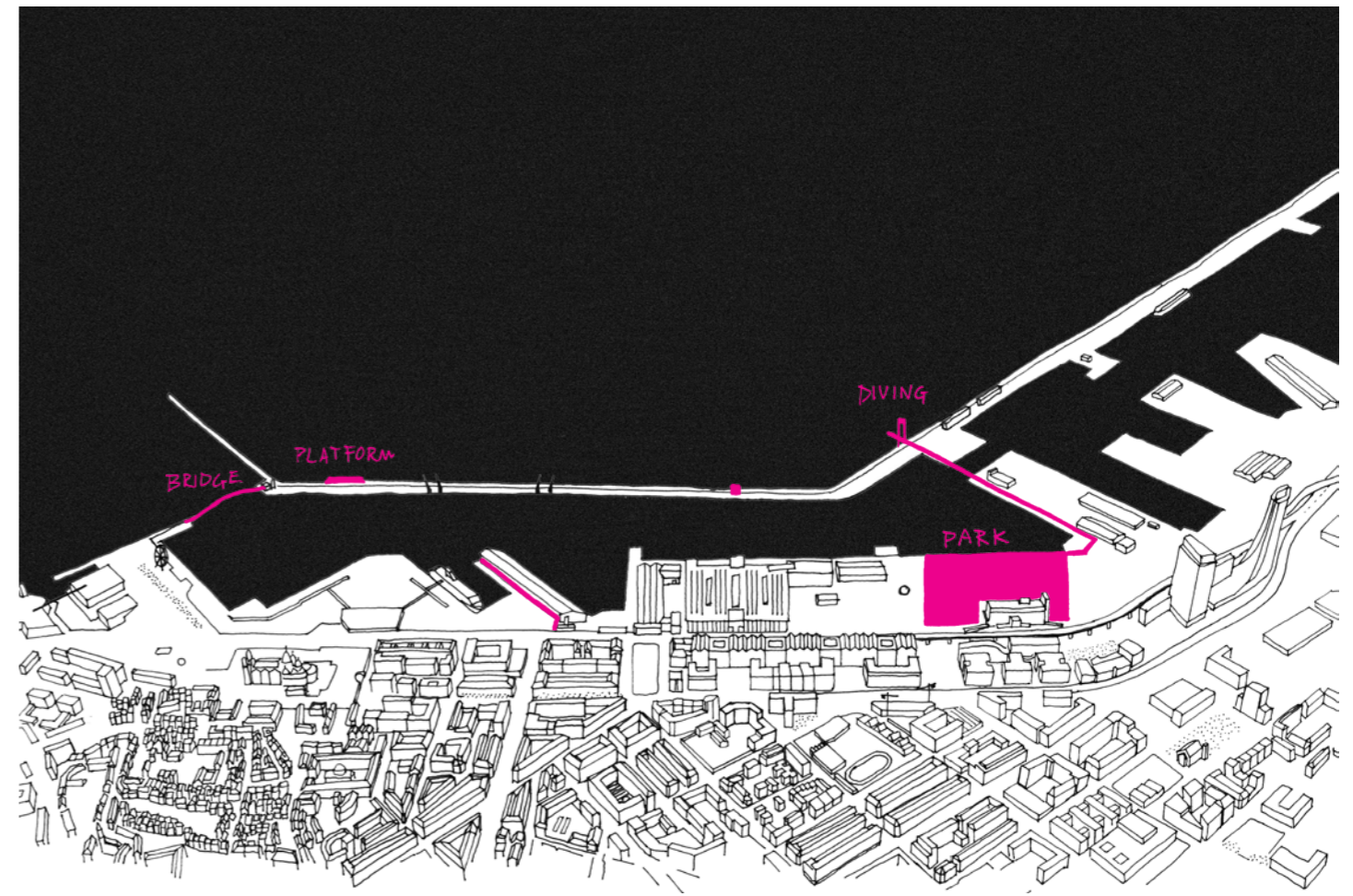

focus on existing spatial elements

open up the area to the shore

add public green areas



# locations

## actions

*Waalhaven*

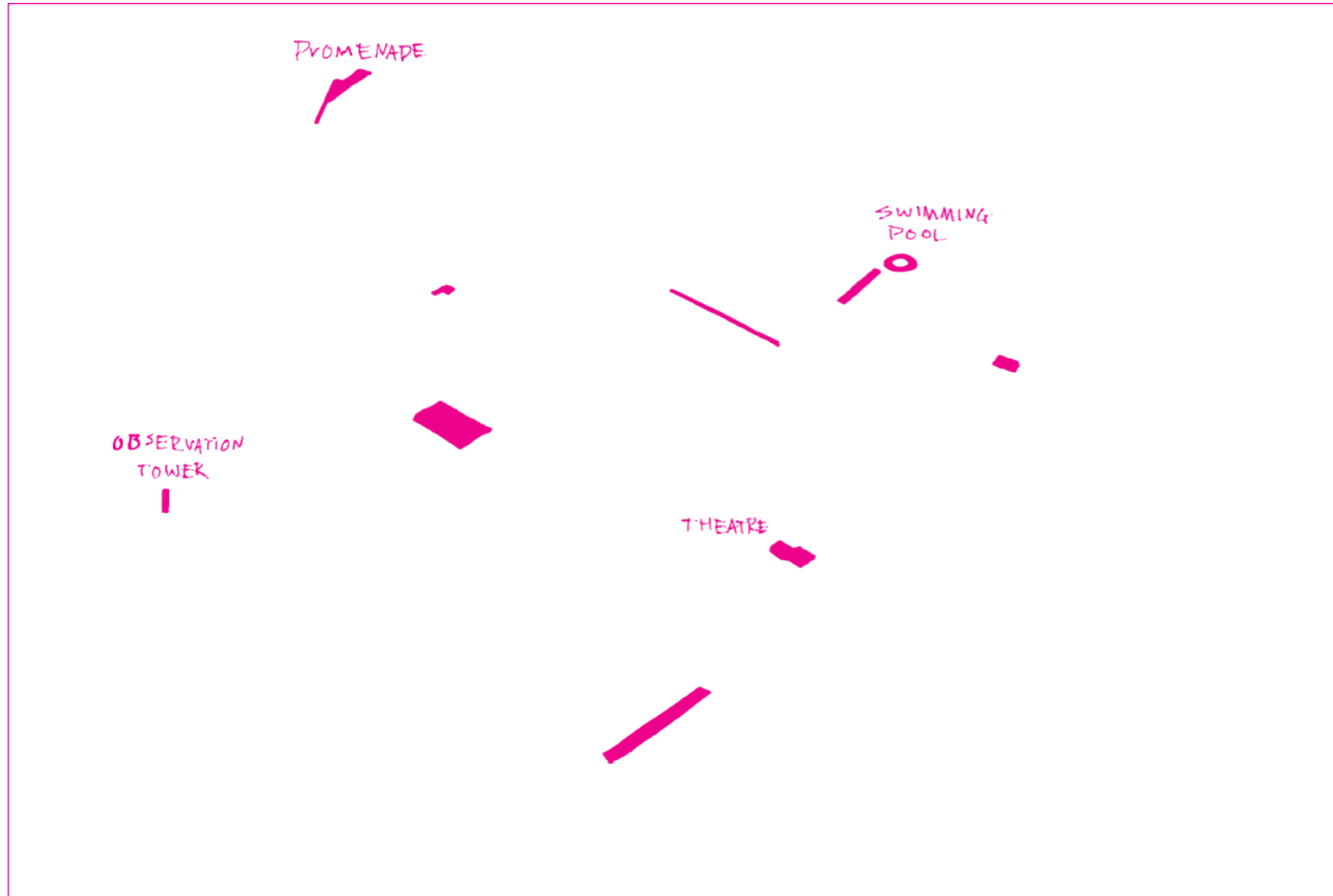

*Le Bassin de la Grande Joliette*

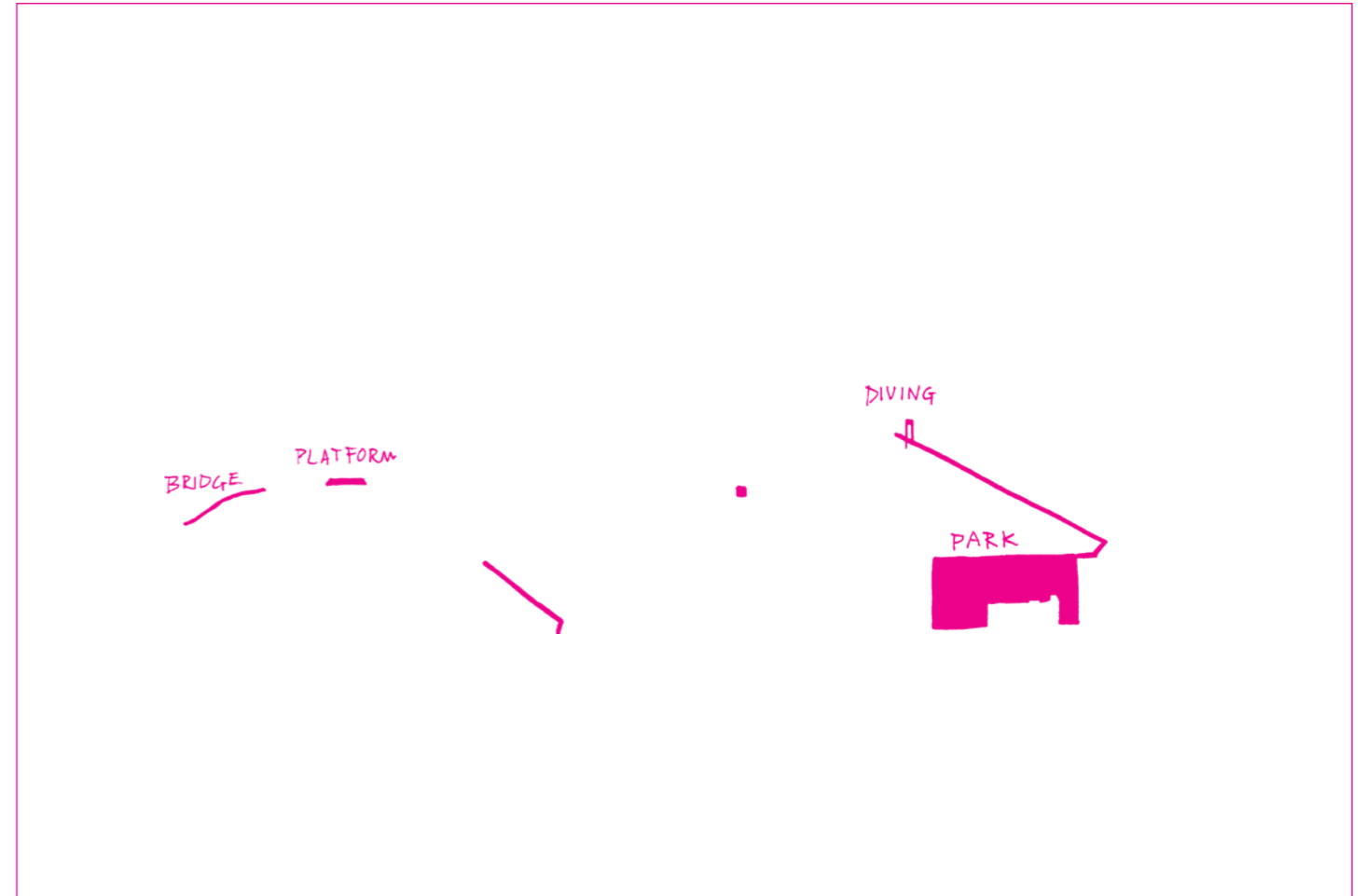

similarities in typology  
differences through contextuality



**interventions**



# interventions

## materials

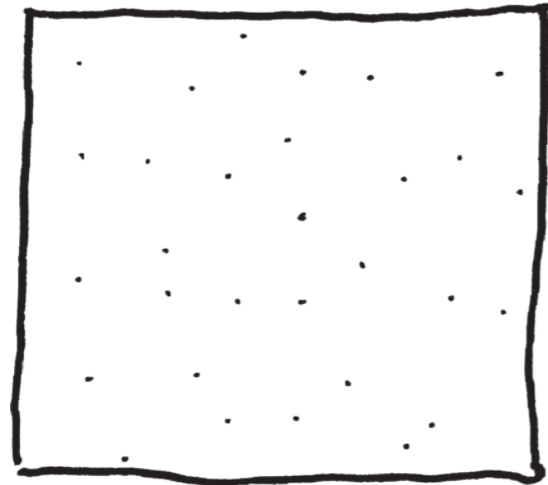

concrete

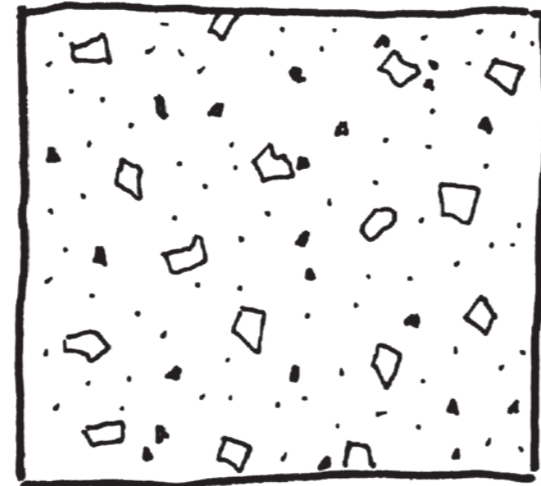

terrazzo

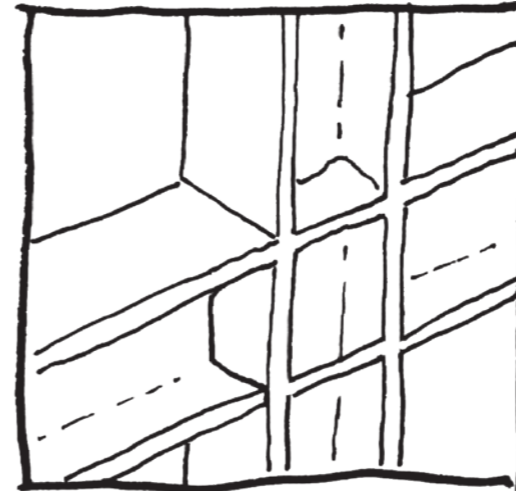

steel

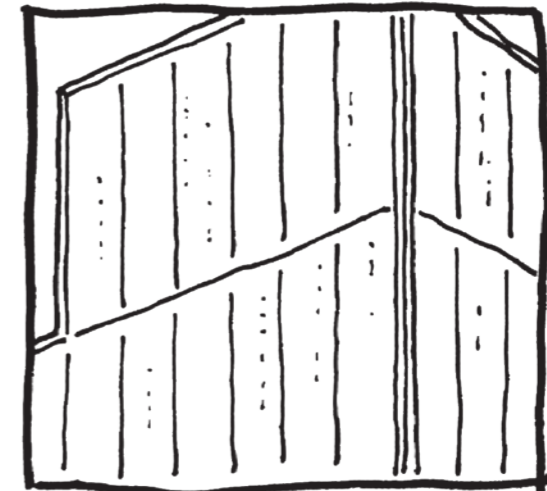

polycarbonate



# Rotterdam

interventions

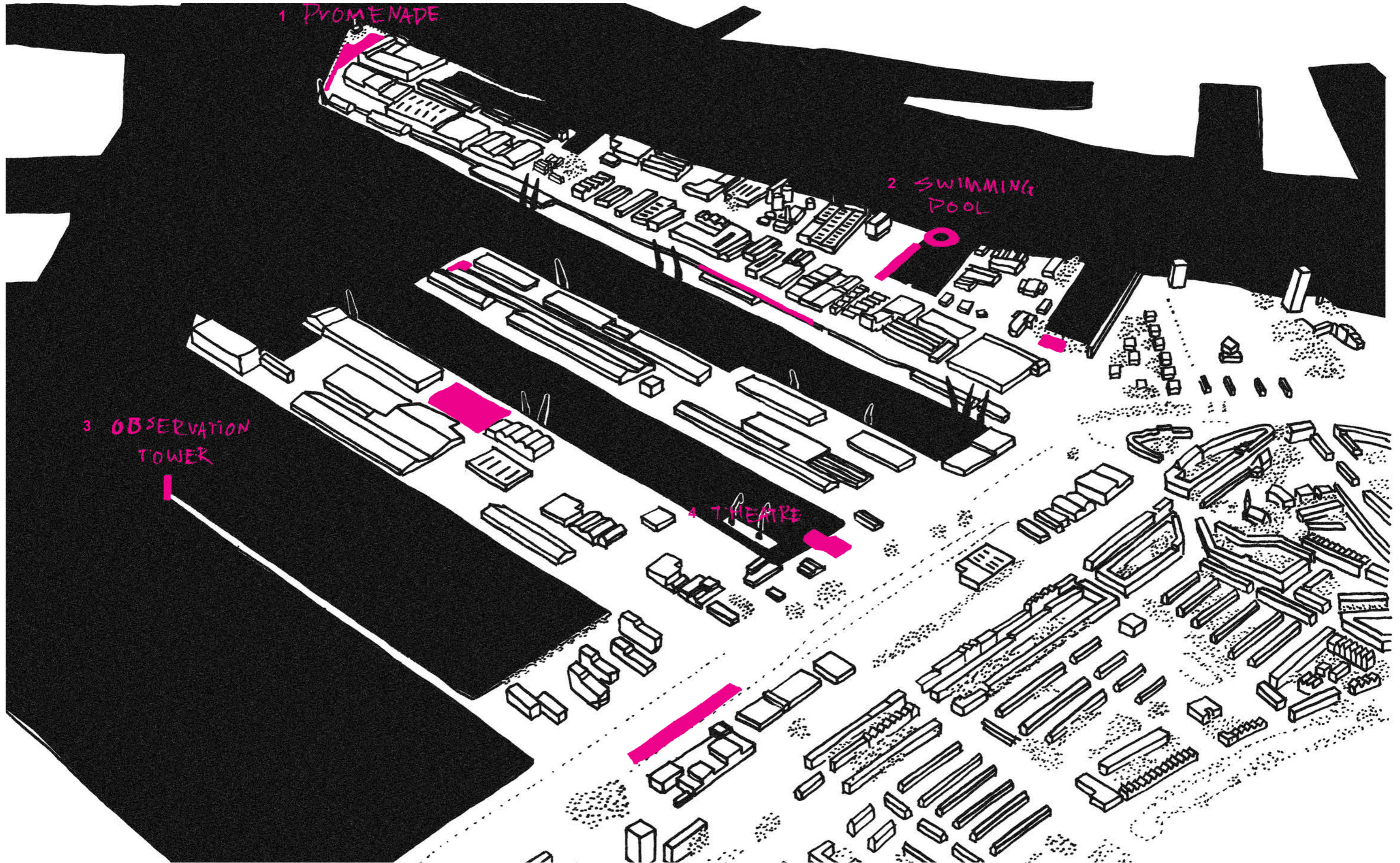



# Rotterdam

promenade

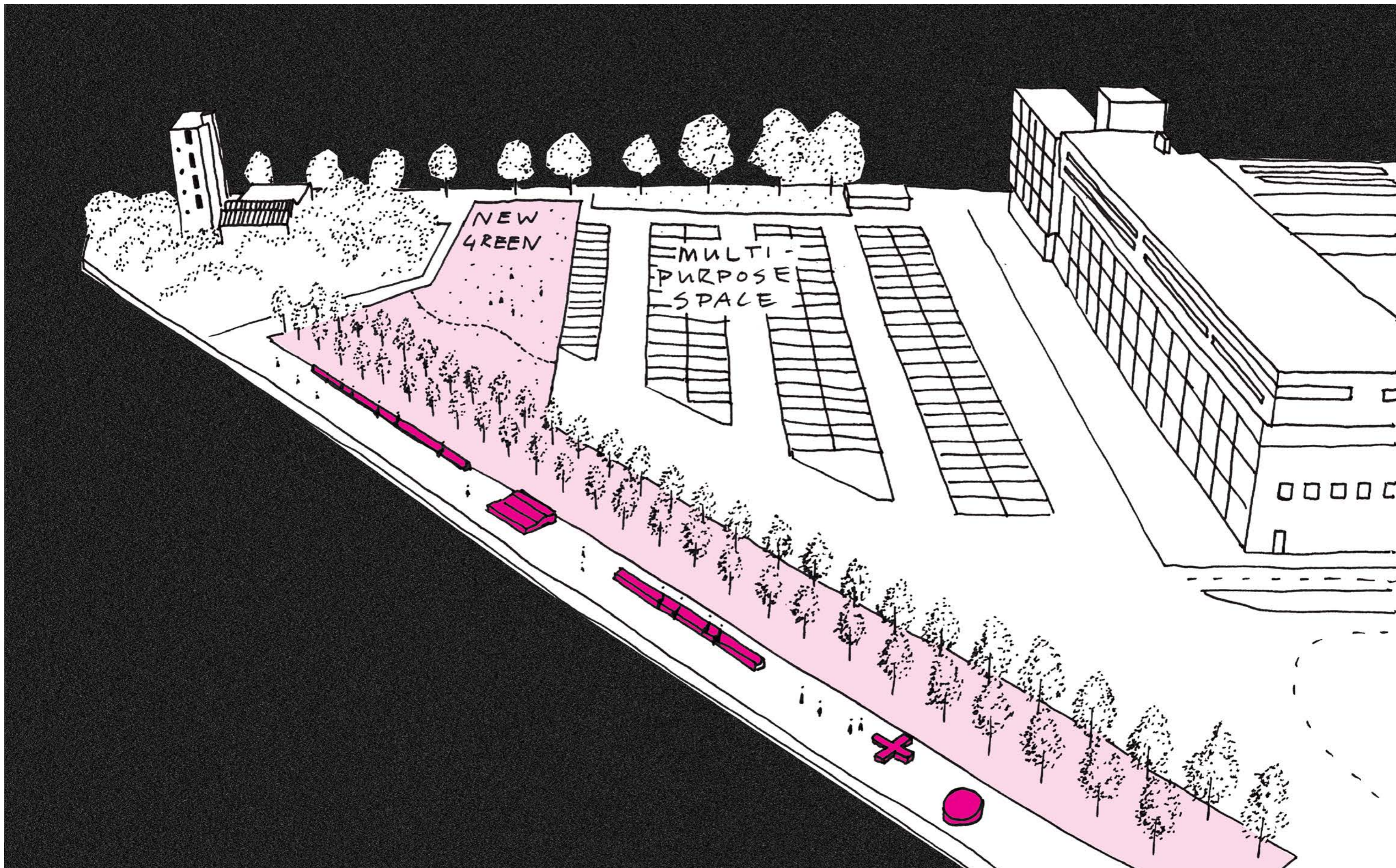



# Rotterdam promenade

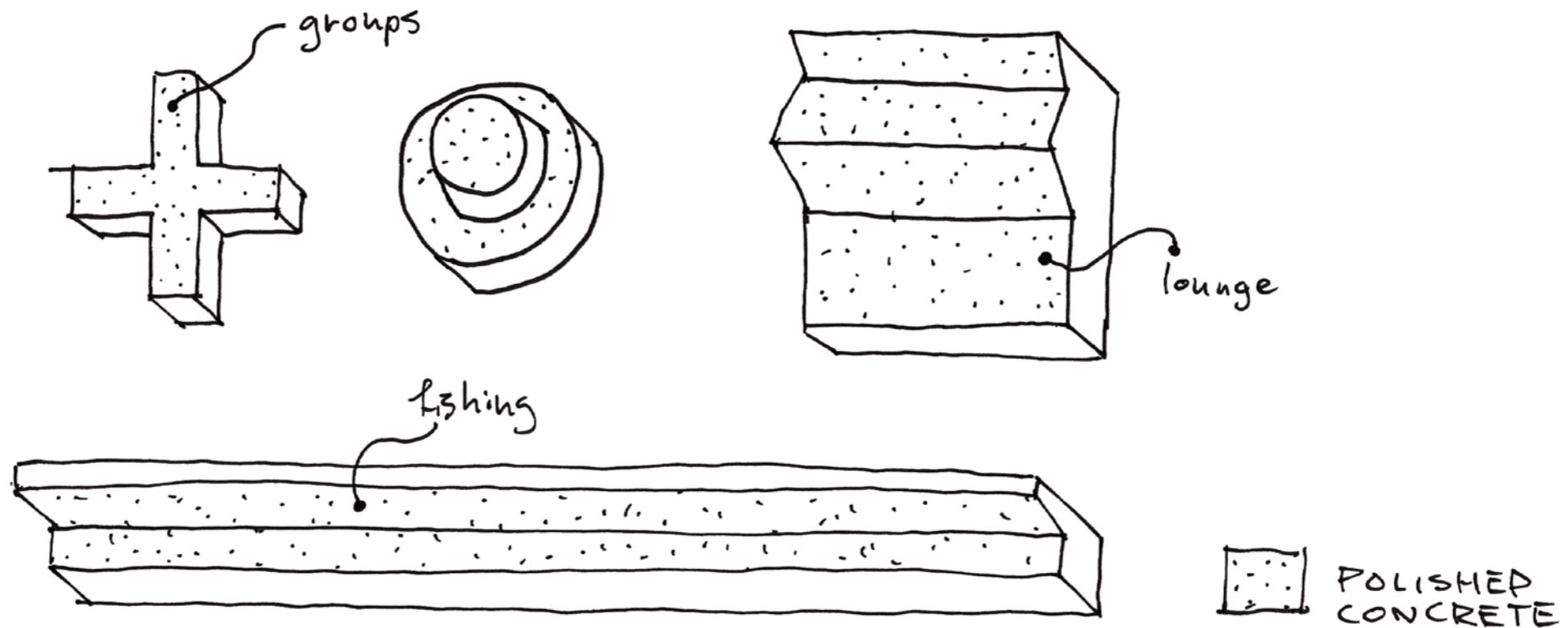

DIFFERENT ELEMENTS

\*marking the boulevard.

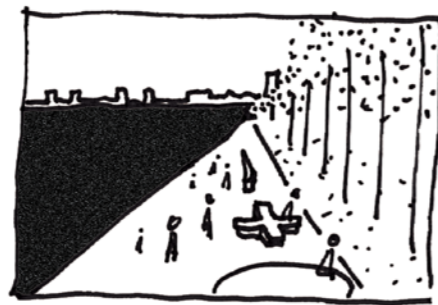

1 STROLLING

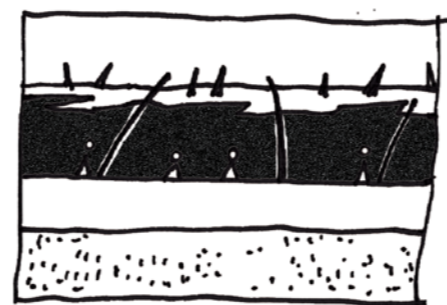

2 FISHING

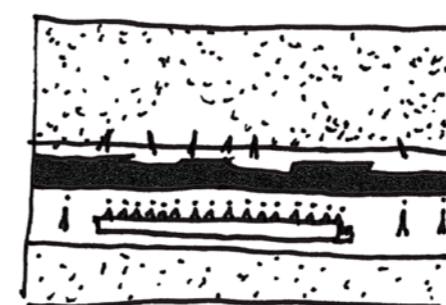

3 FASHION SHOW?







# Rotterdam

swimming pool

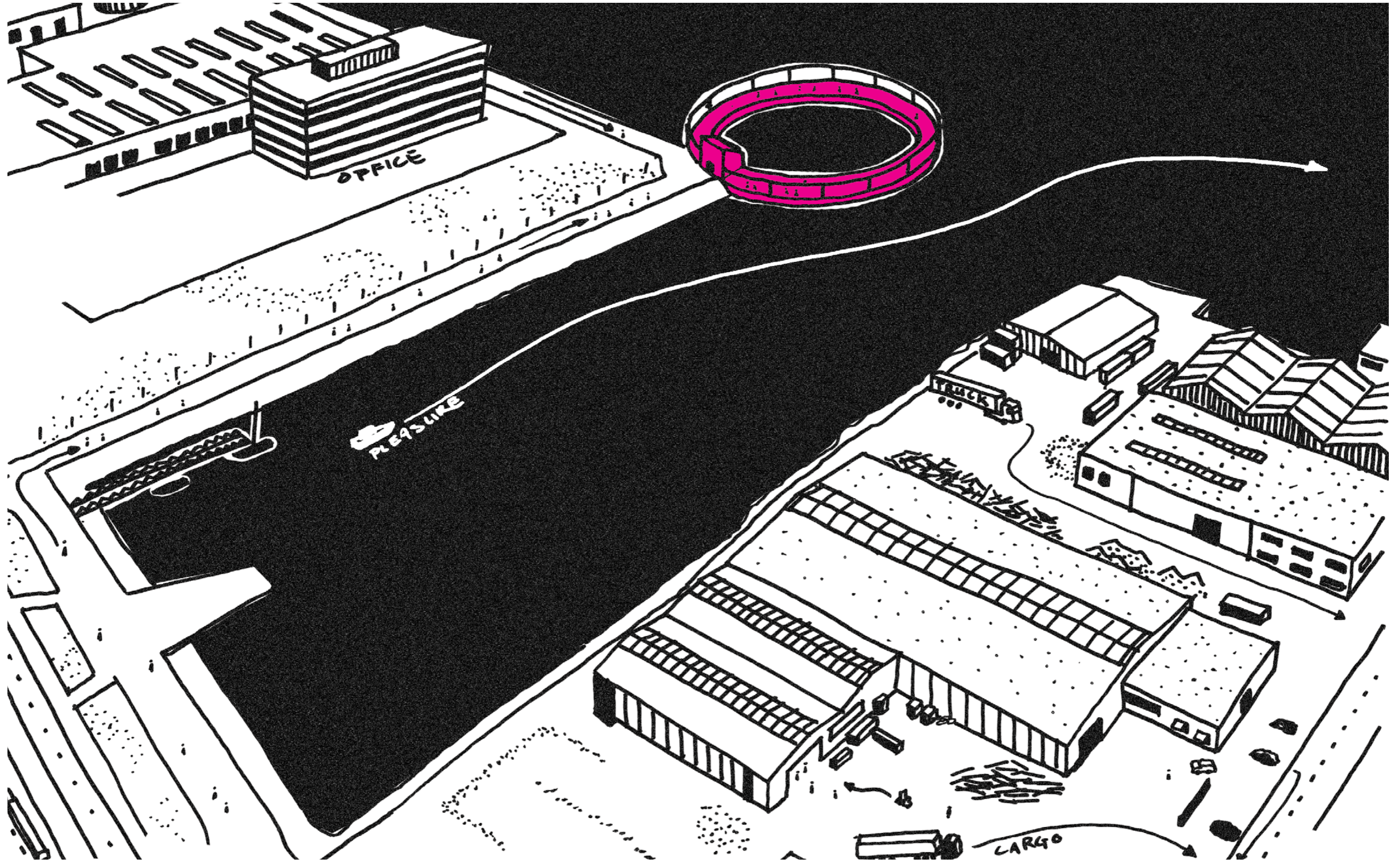



# Rotterdam swimming pool

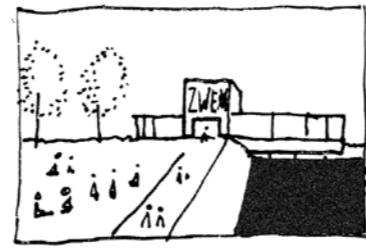
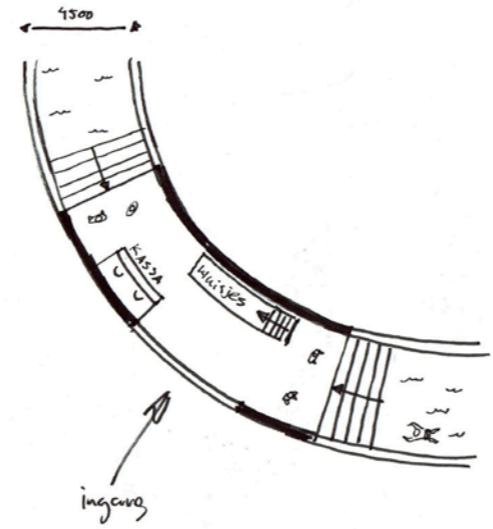
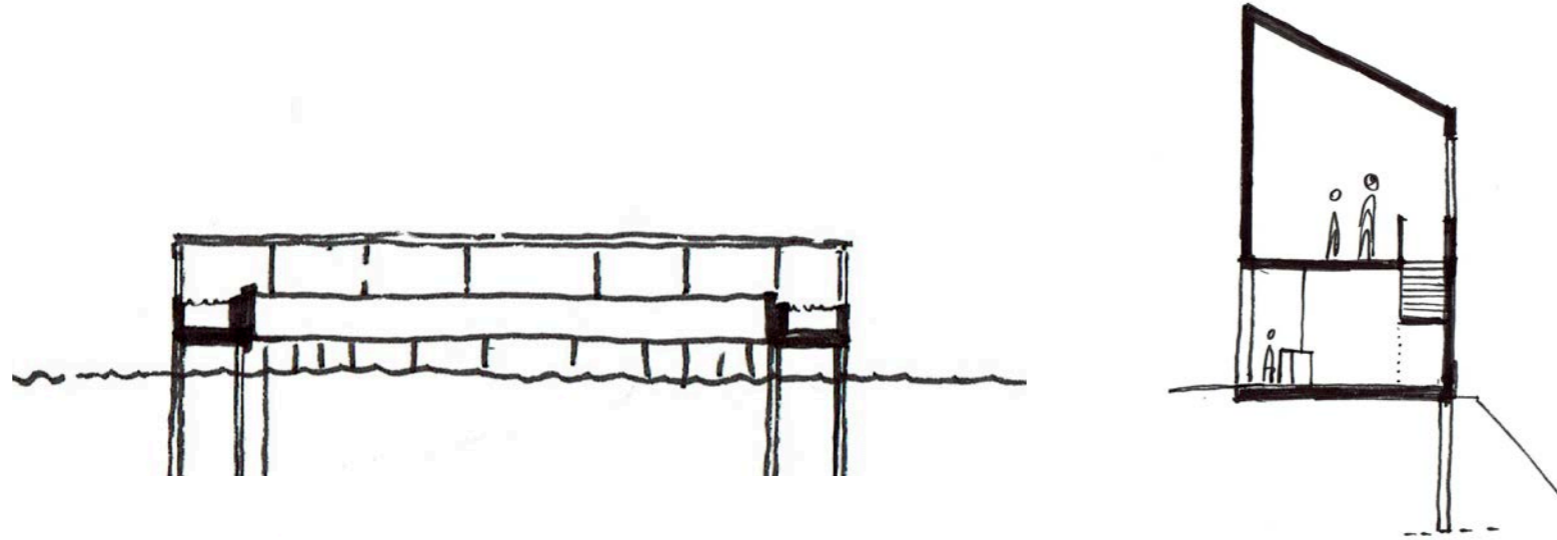

1 SUN BATHING

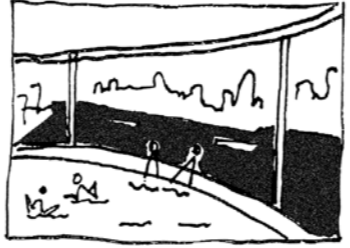

2 SWIMMING  
WITH SHIPS

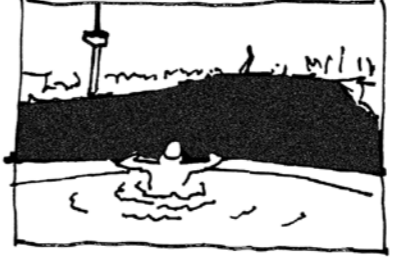

3 SWEEPING  
VIEWS







# Rotterdam

observation tower

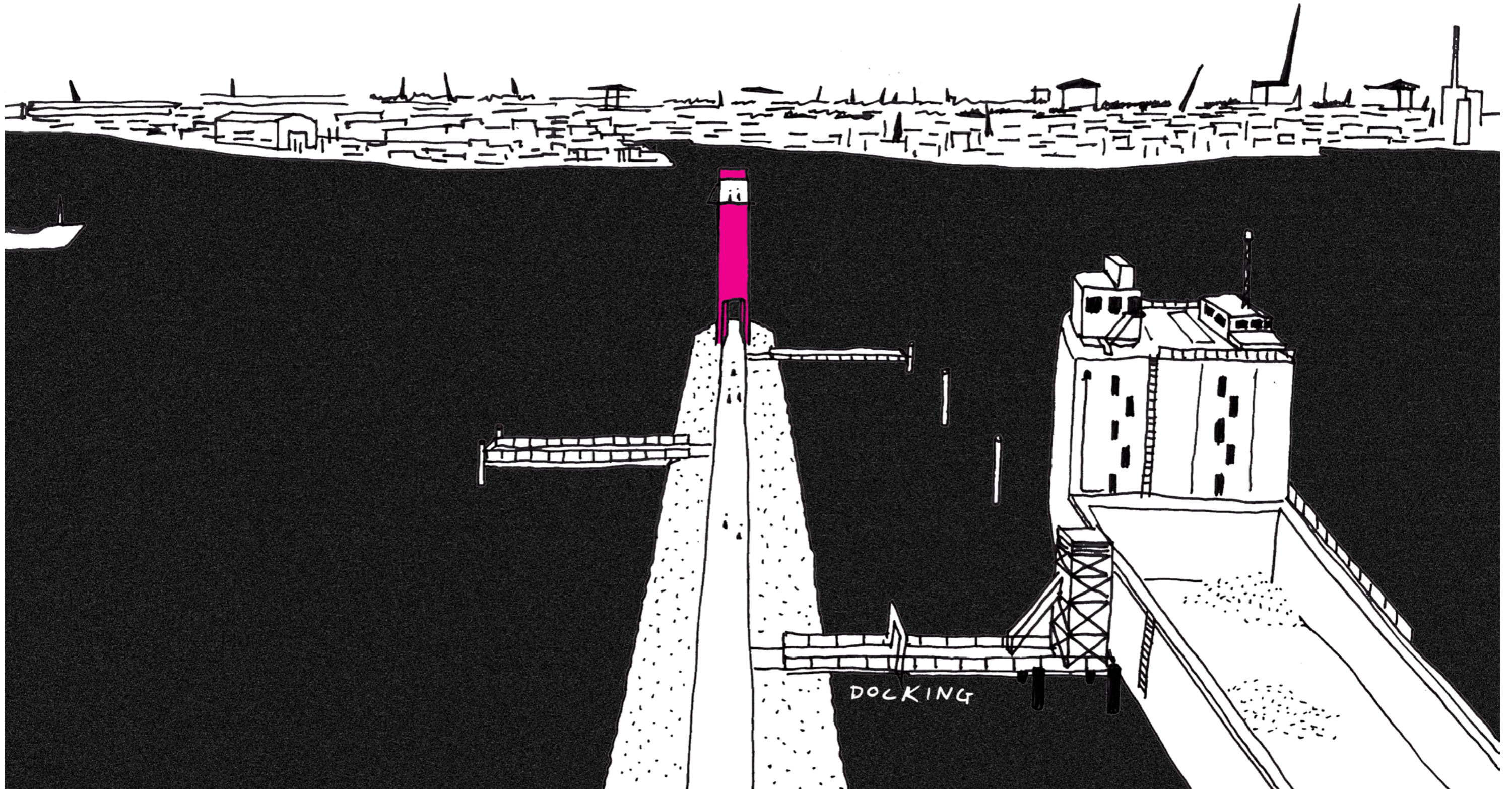



# Rotterdam

observation tower

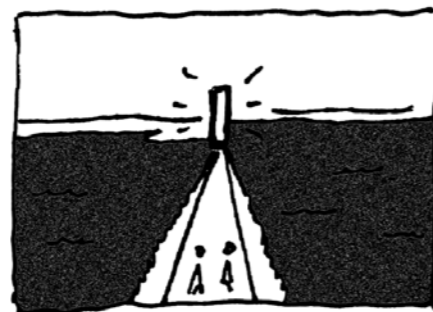
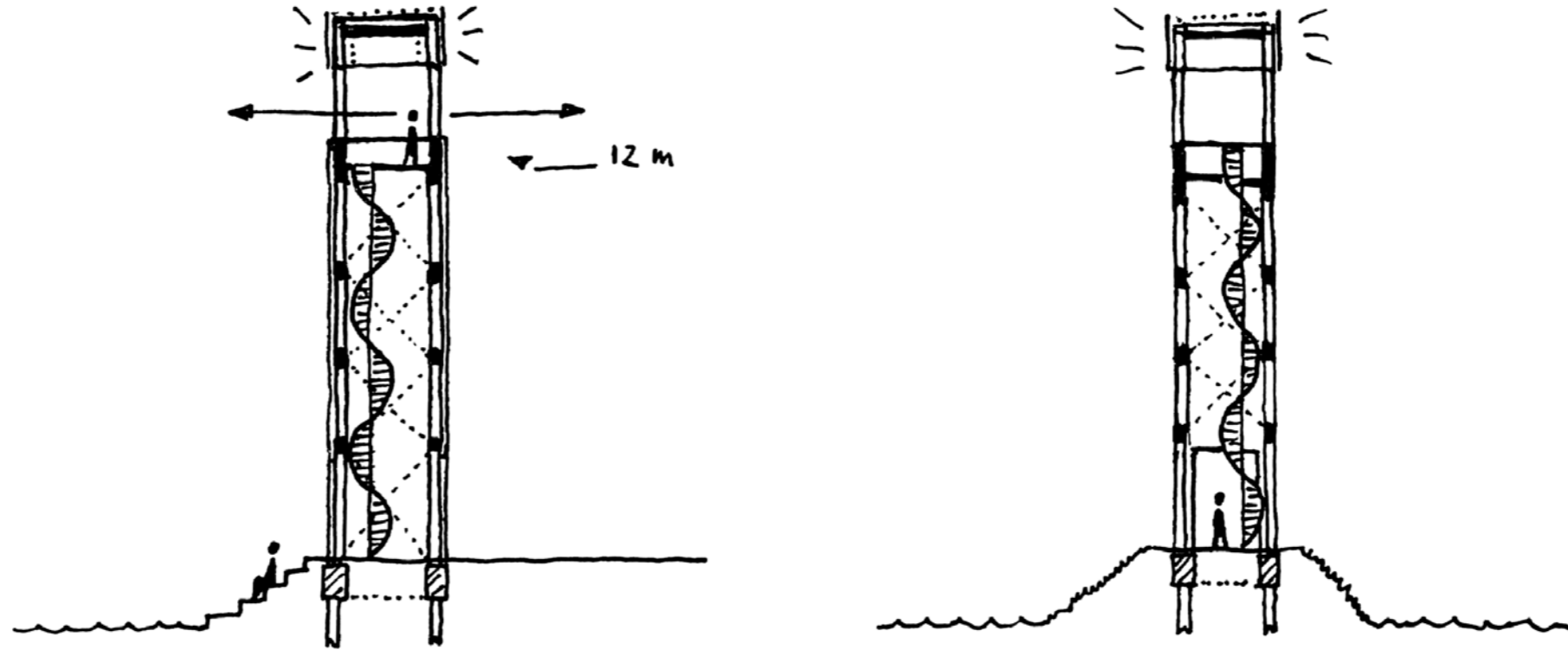

1 BEACON



2 ENTRANCE

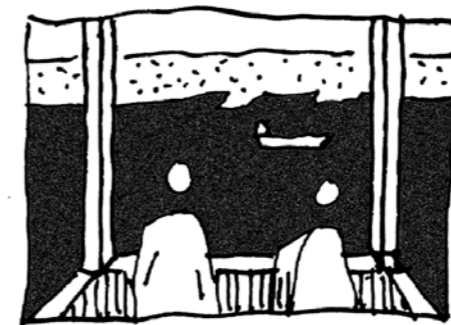

3 HARBOUR  
VIEWS



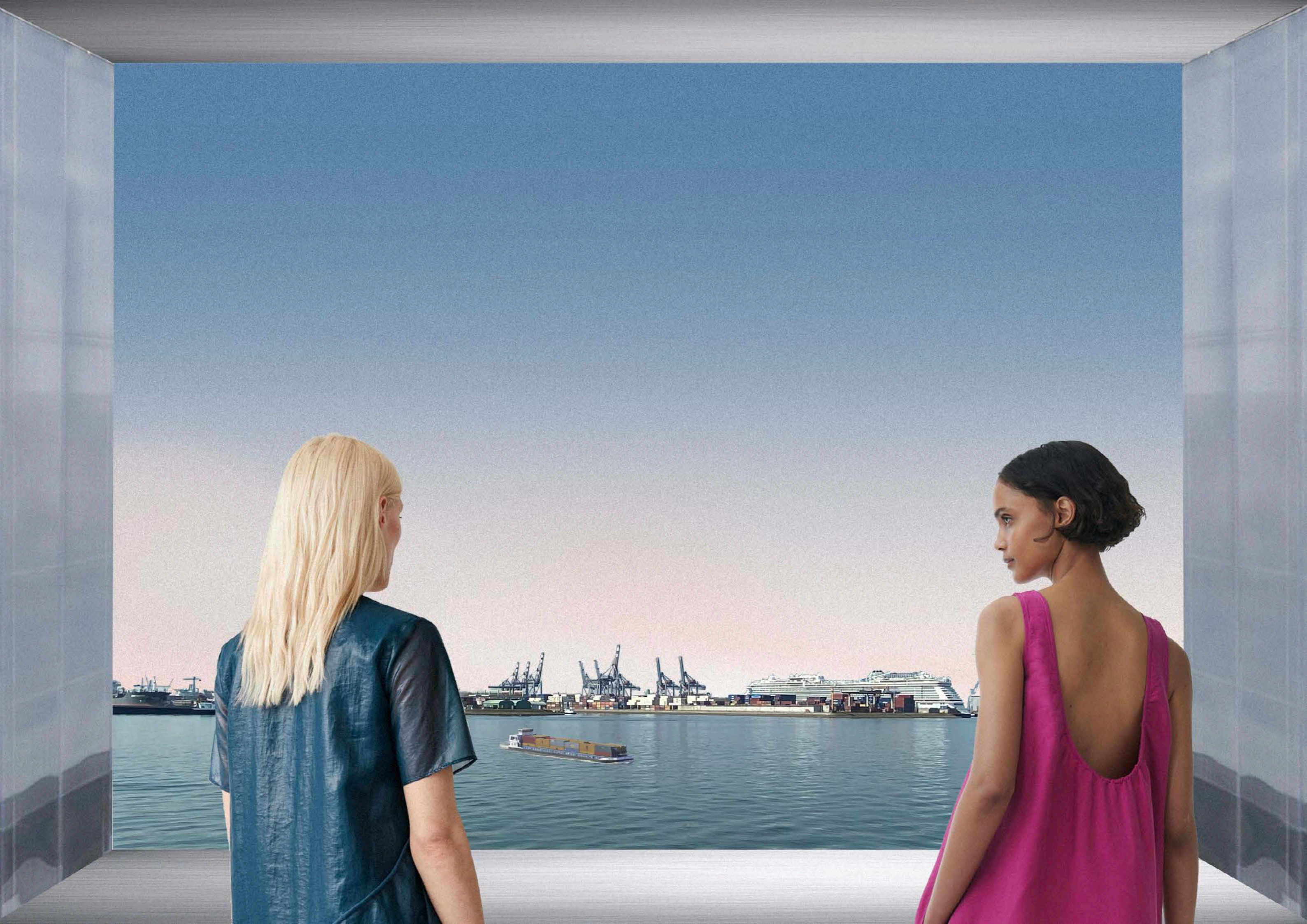



# Rotterdam theatre

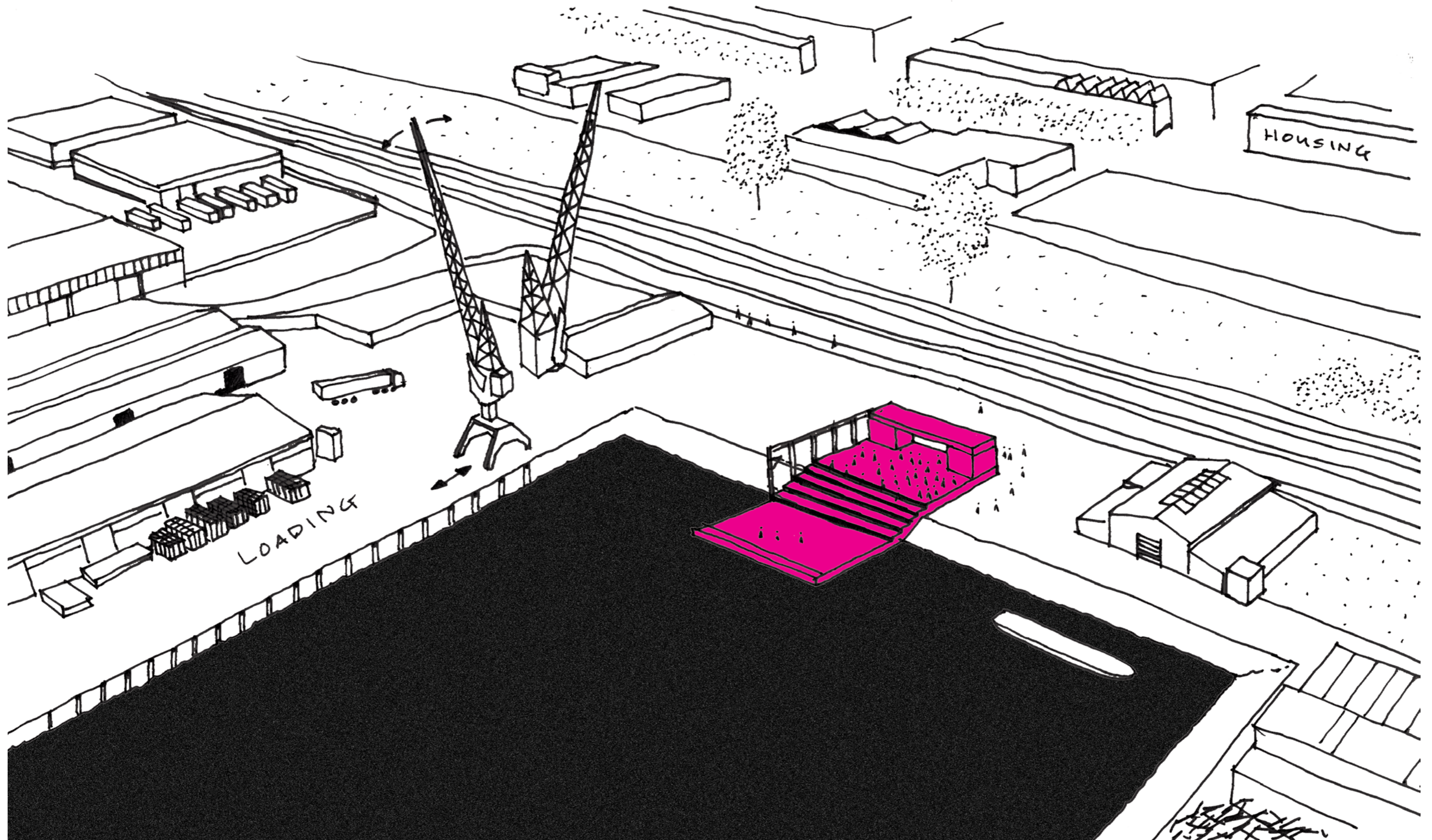



# Rotterdam theatre

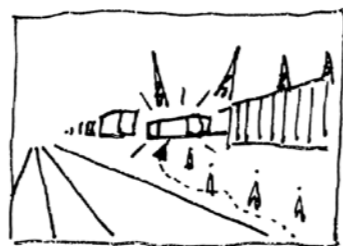
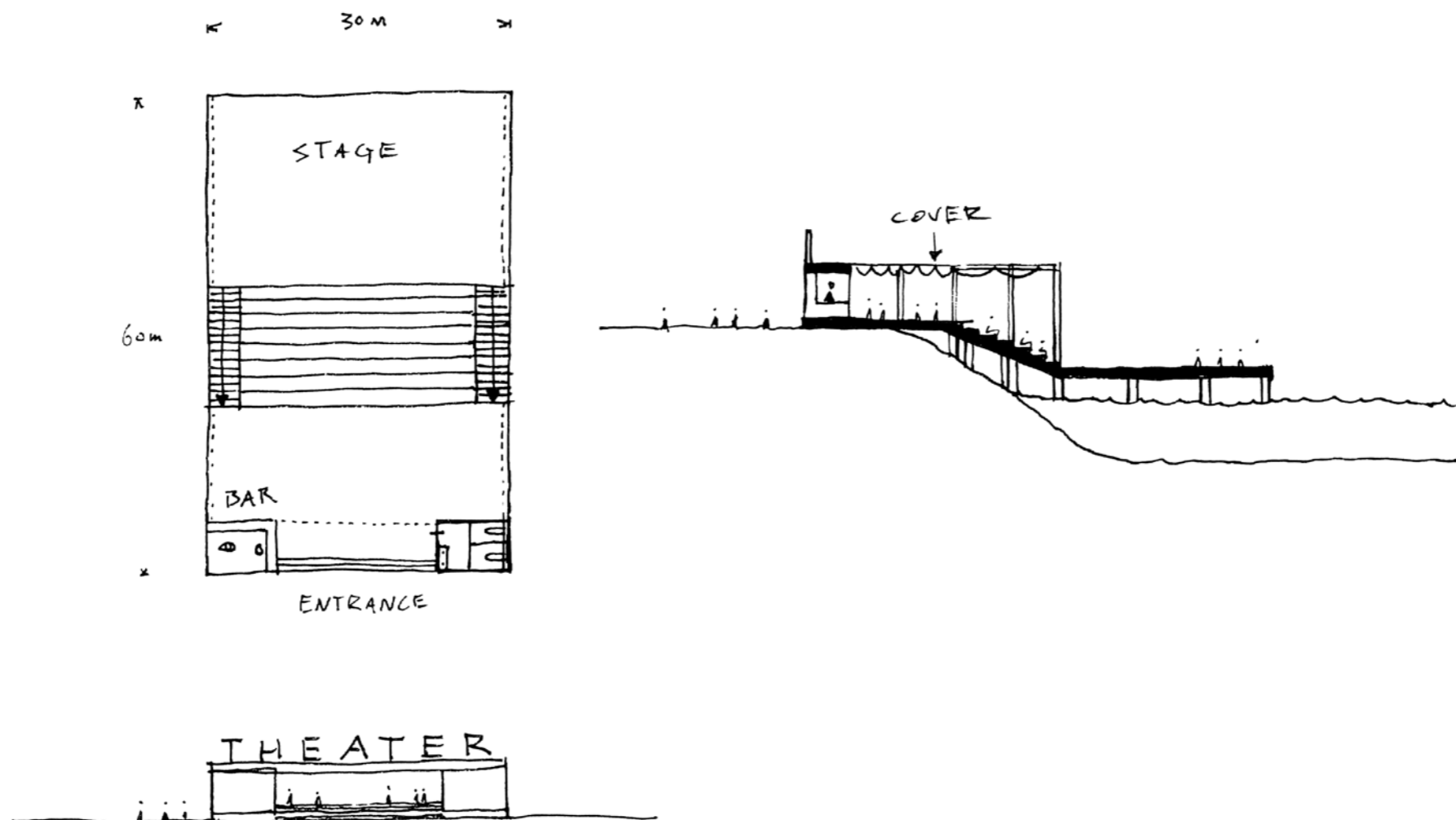

1 INDUSTRIAL SURROUNDINGS

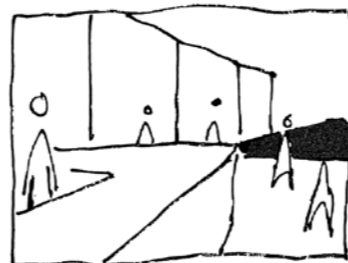

2 ENTRANCE

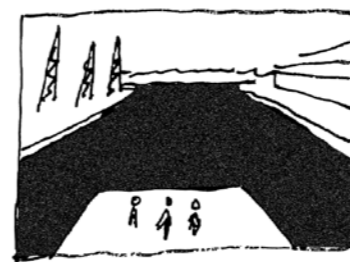

3 CHANGE OF SCENERY







# Marseille

interventions

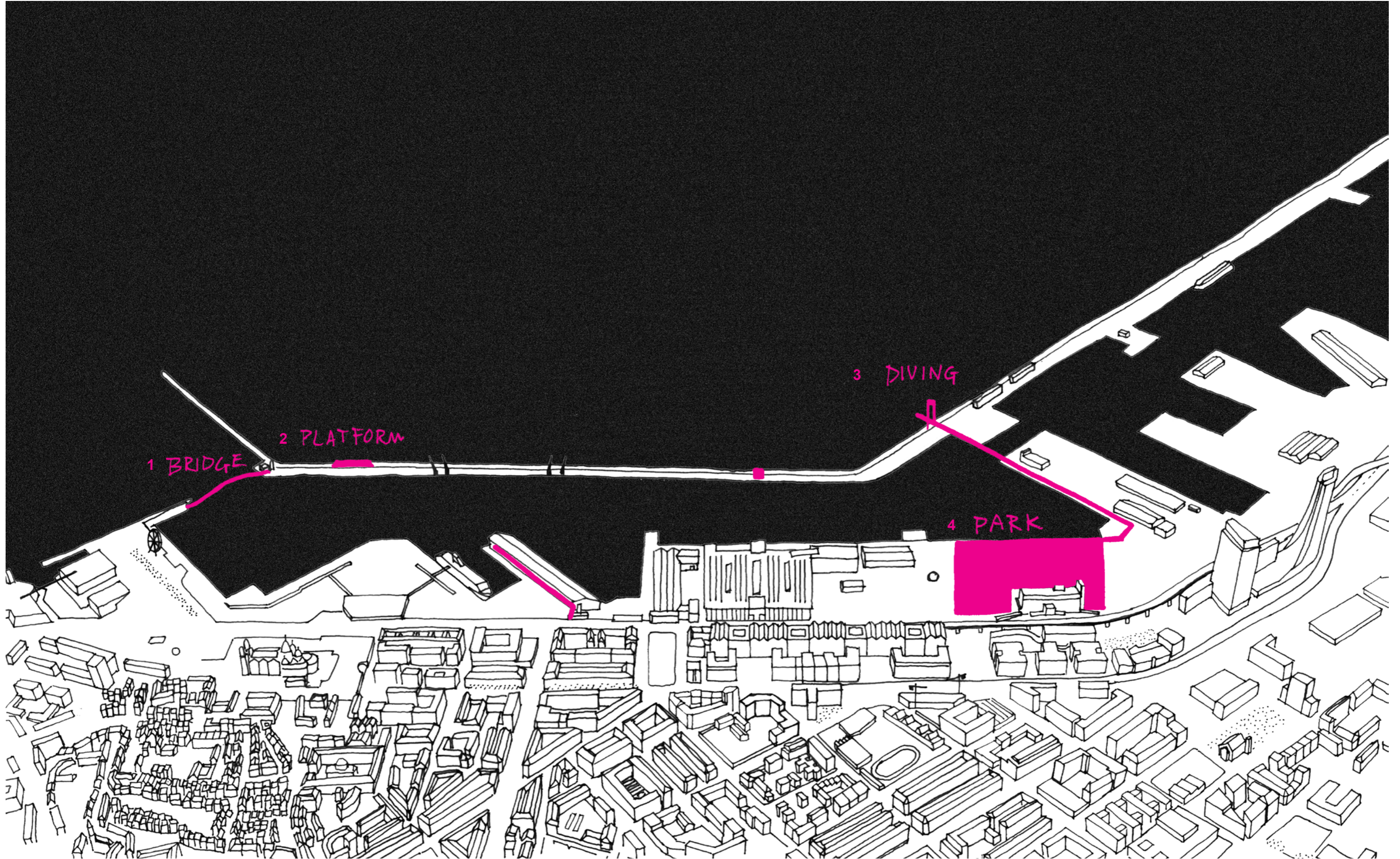



# Marseille

bridge

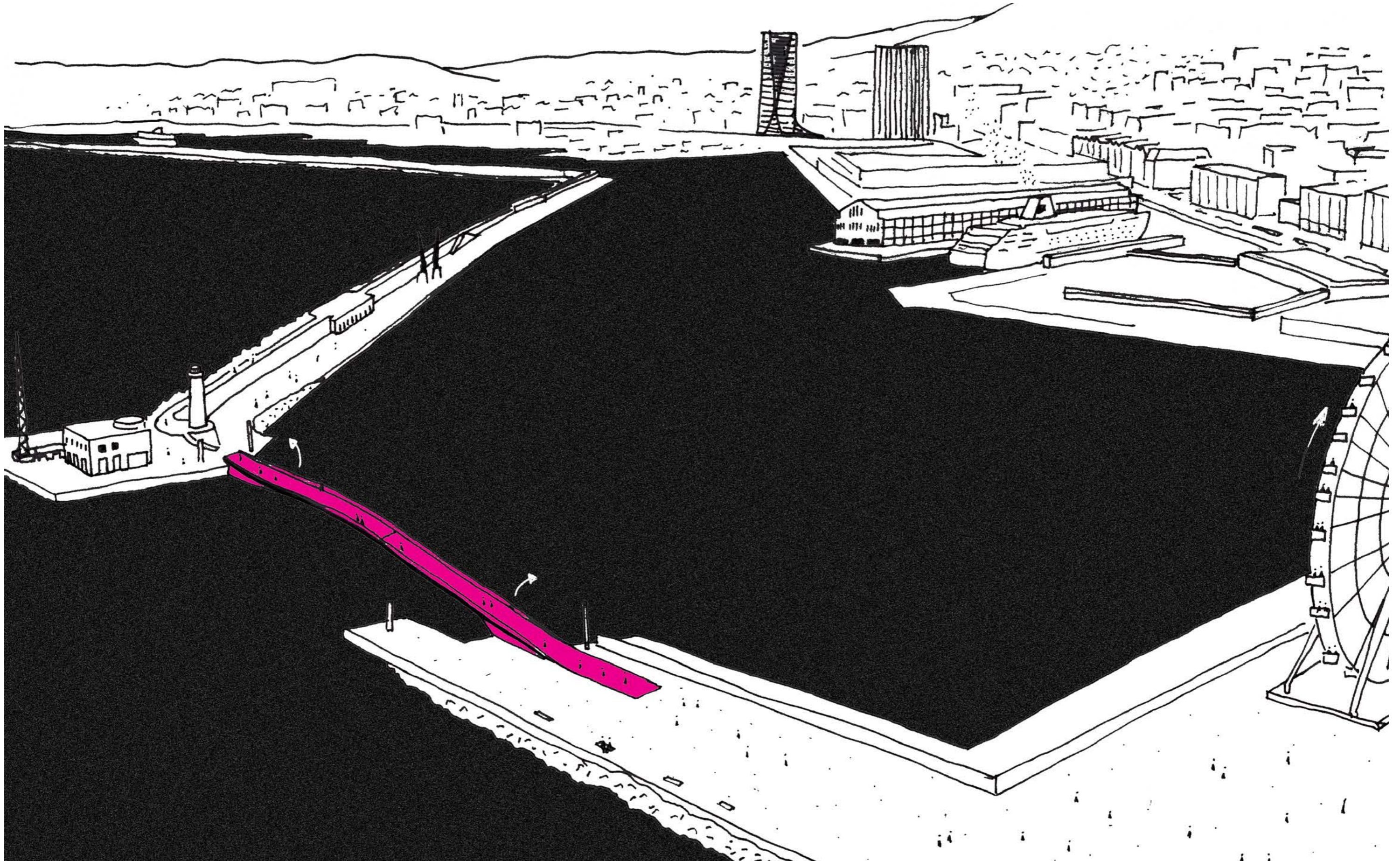



# Marseille

bridge

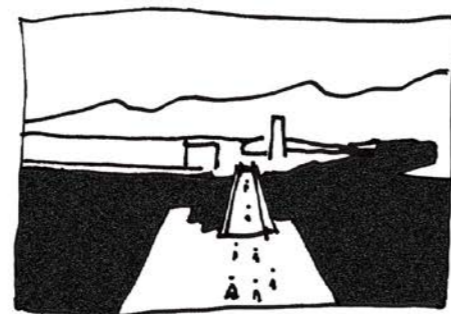
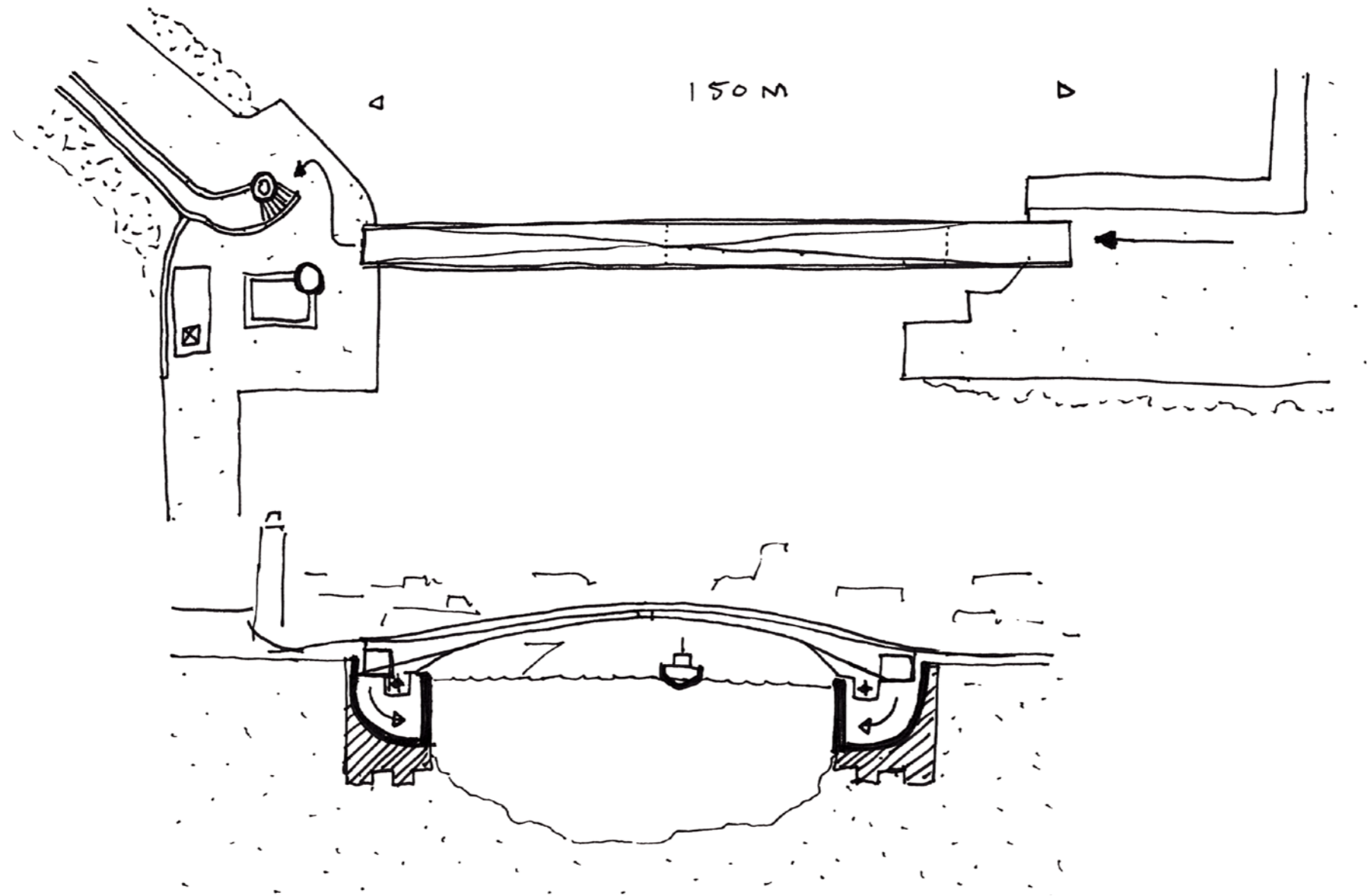

1 CONNECTION

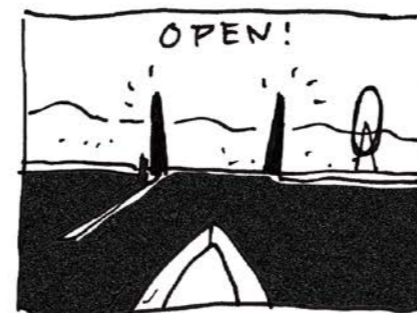

2 OPEN

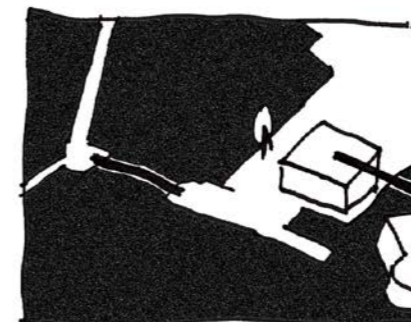

3 NEW CITY ROUTES







# Marseille

platform

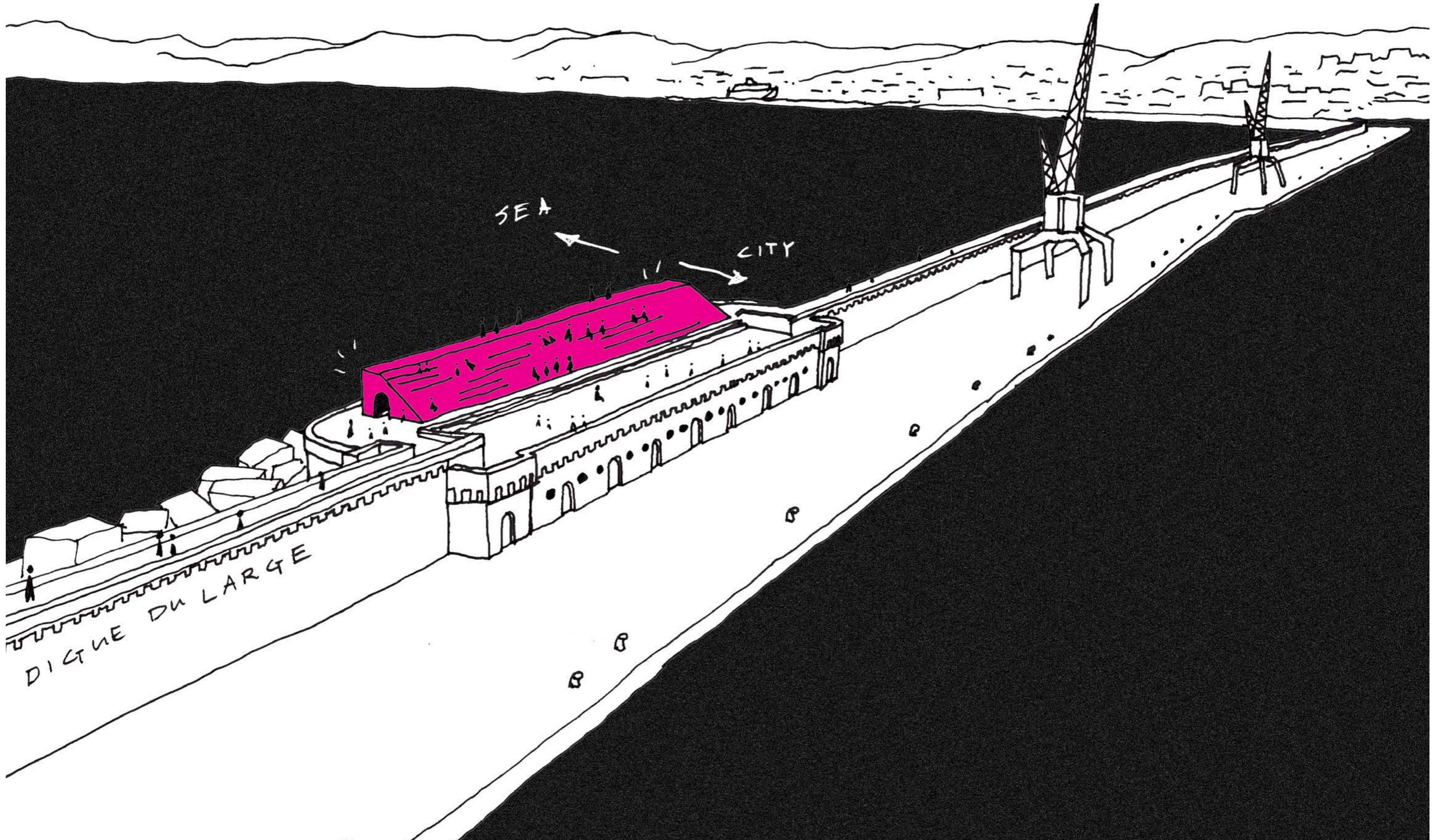



# Marseille

platform

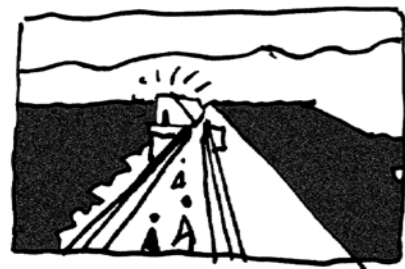
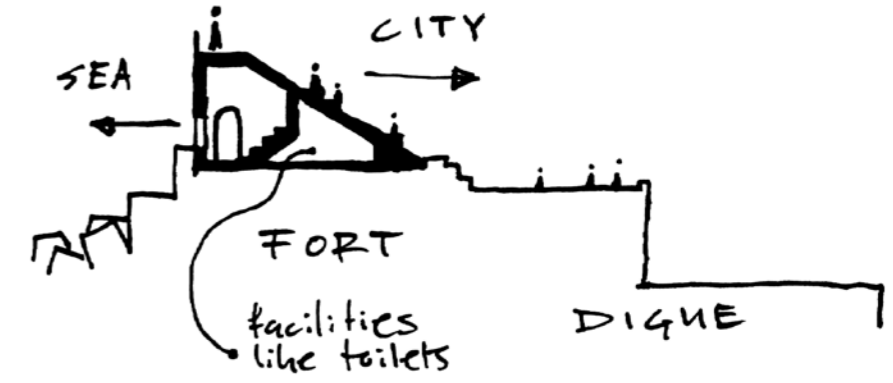
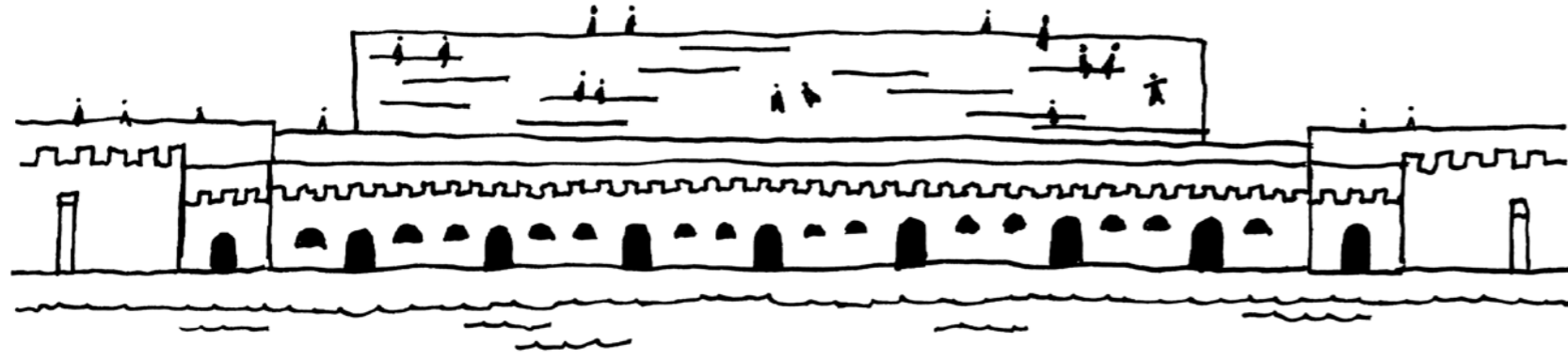

1 APPROACH

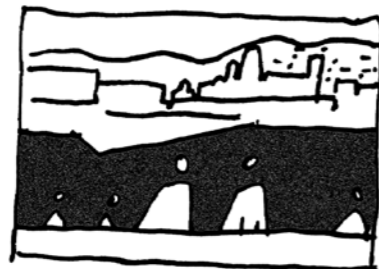

2 CITY VIEW

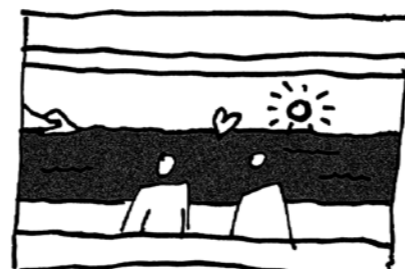

3 SUNSET



love the city ♥ embrace the port

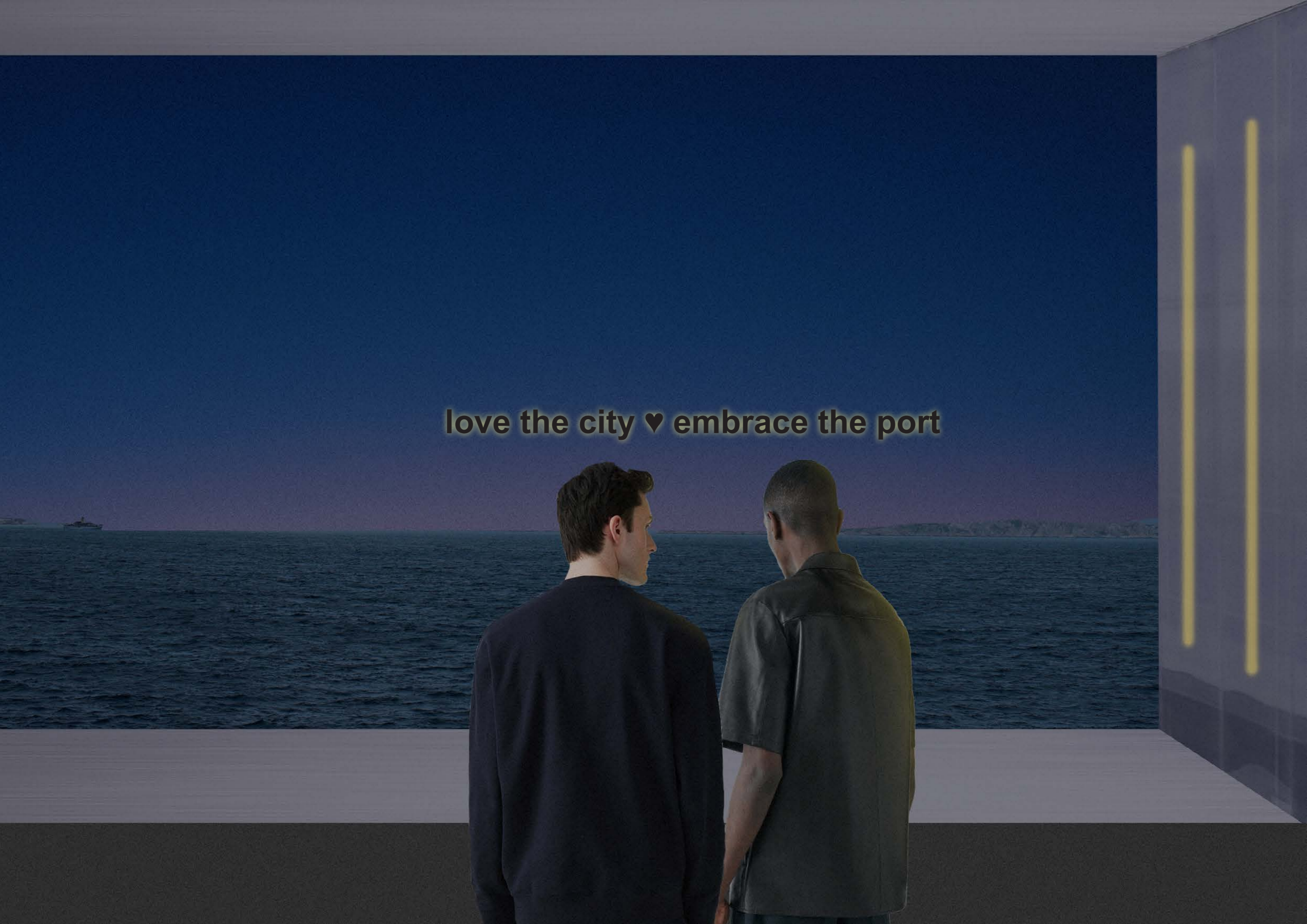



# Marseille

diving walkway

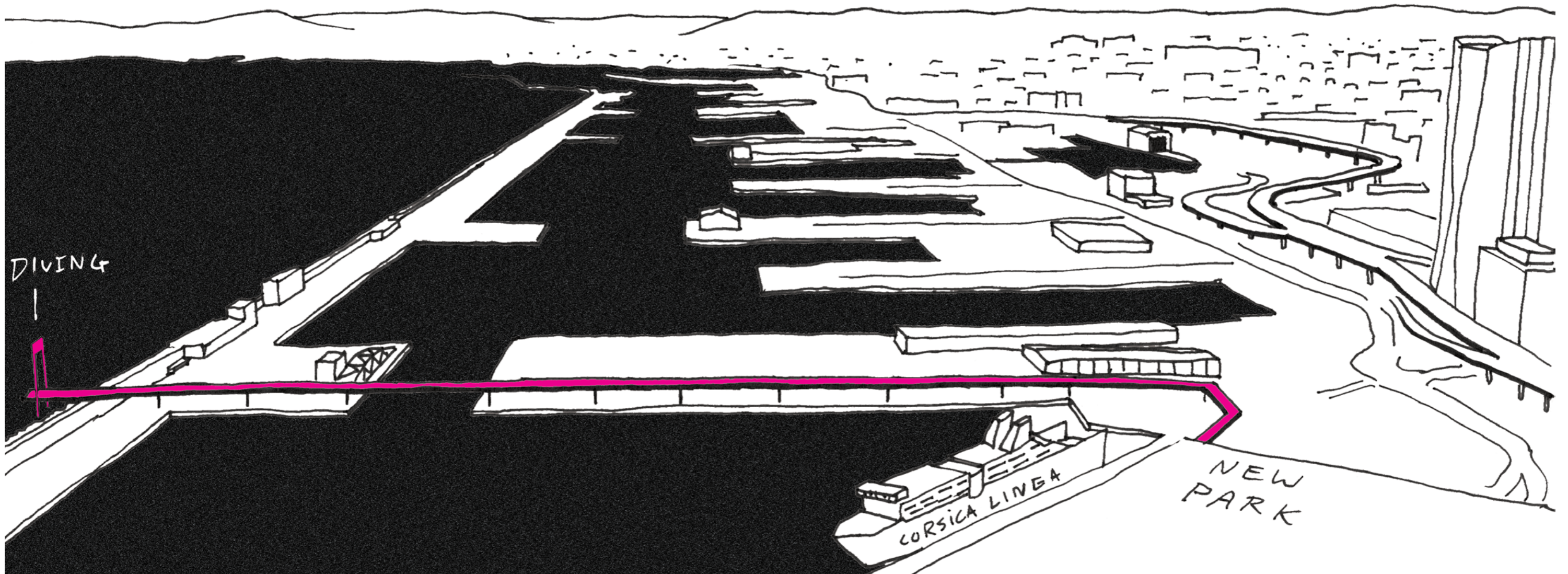



# Marseille

diving walkway

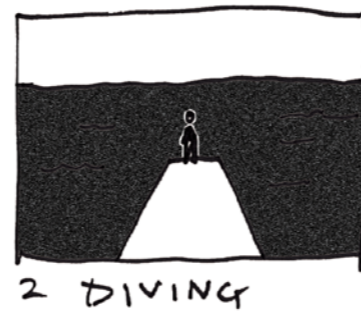
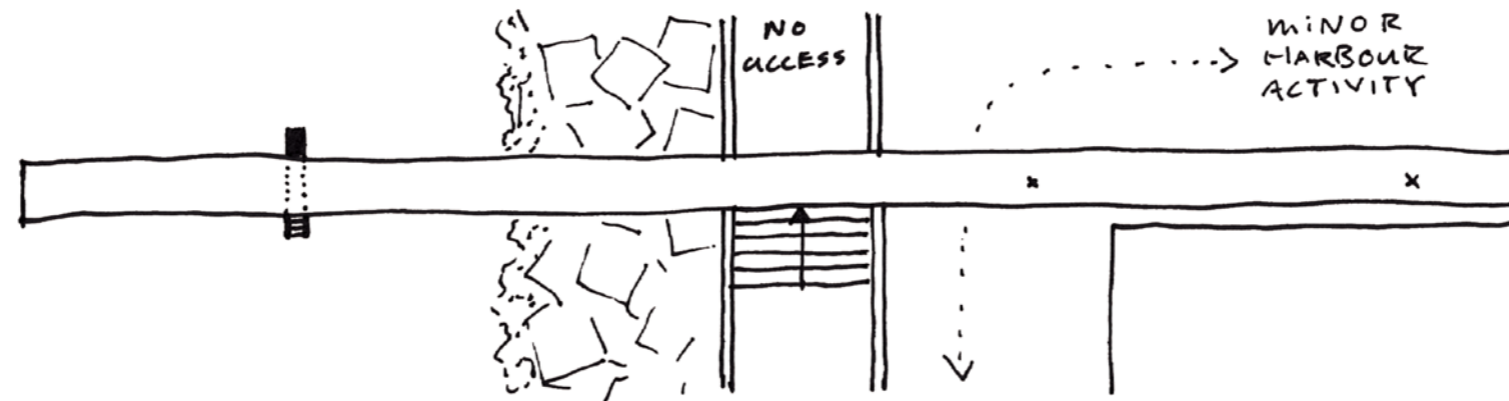
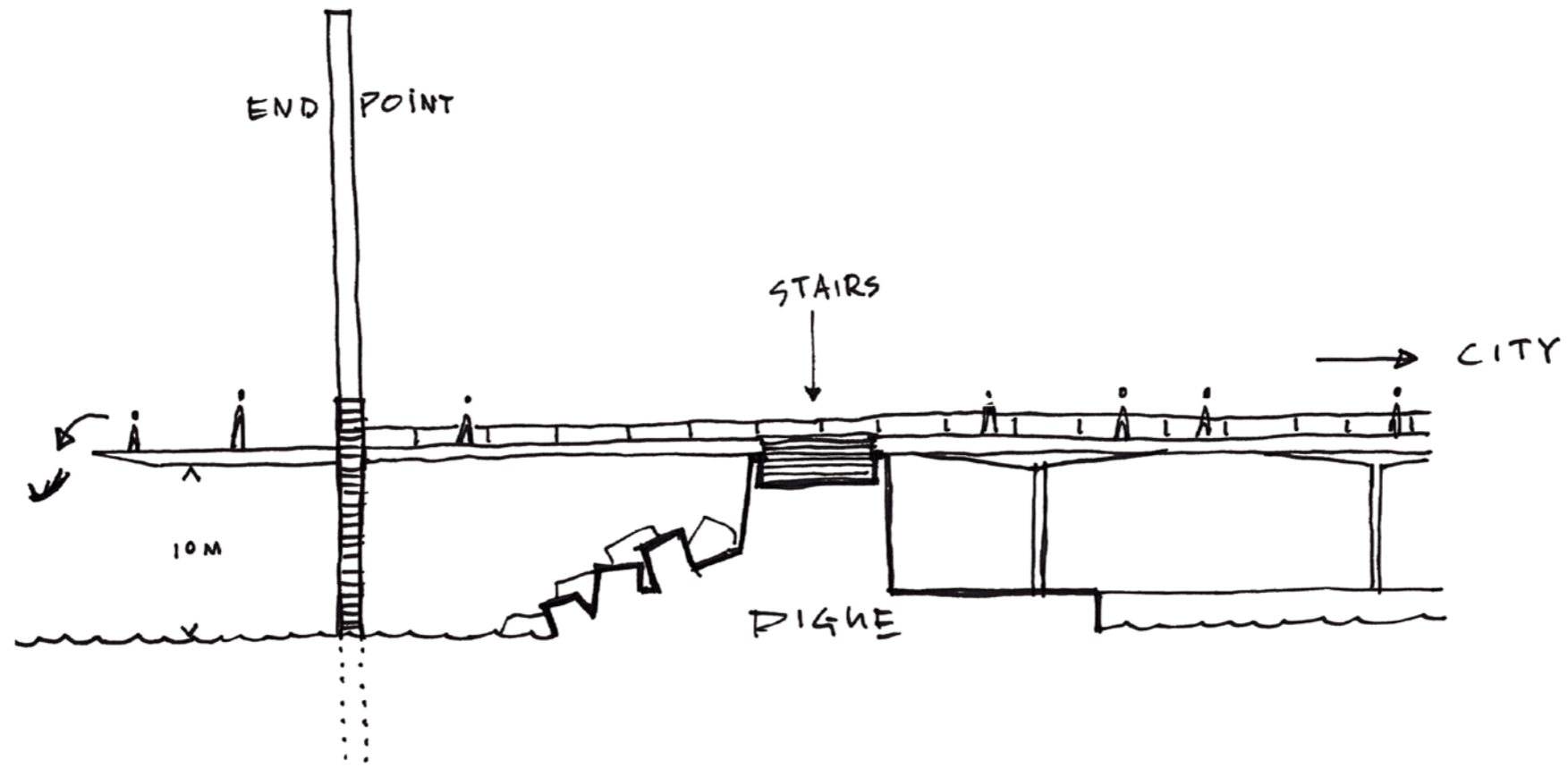







# Marseille

park

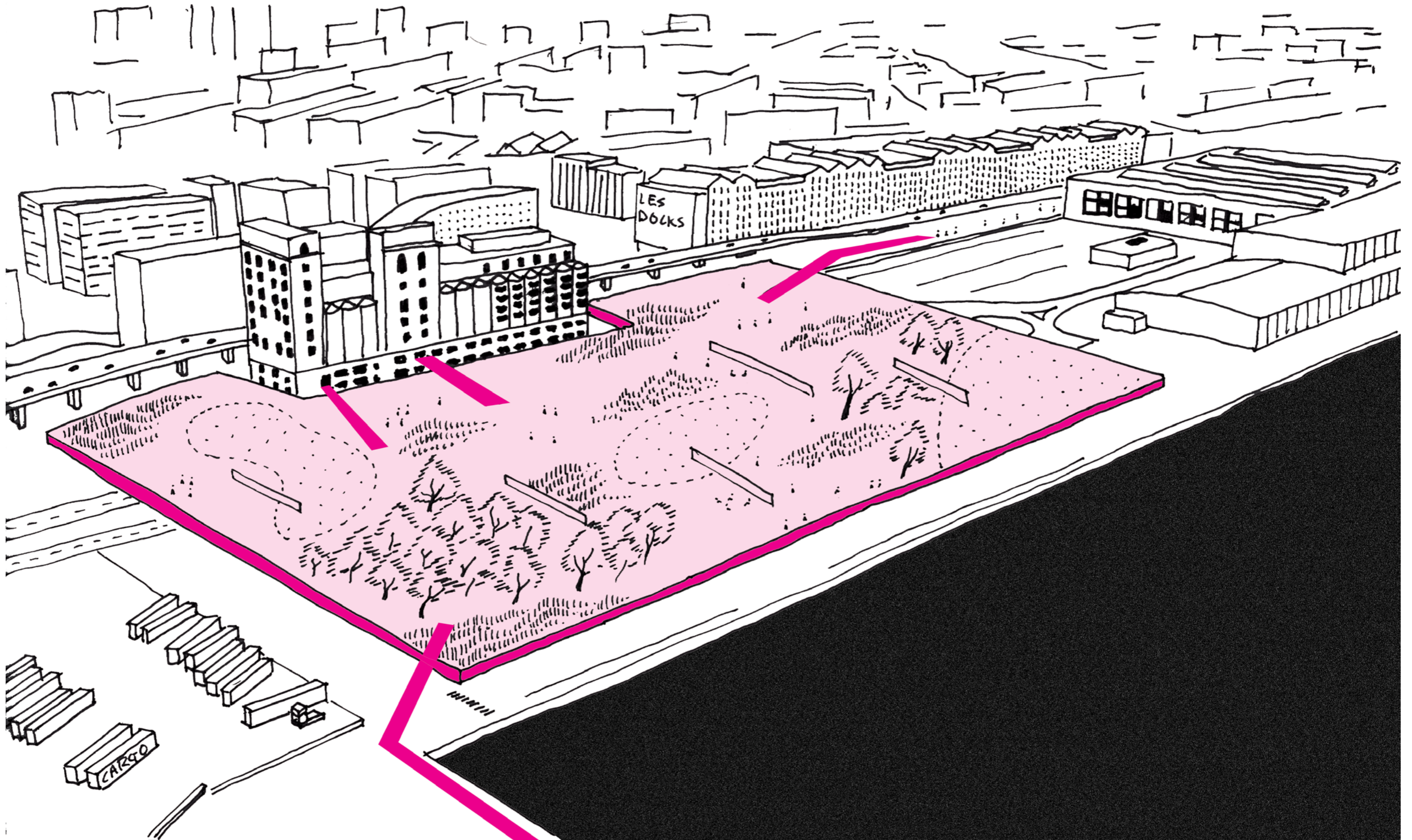



# Marseille

park

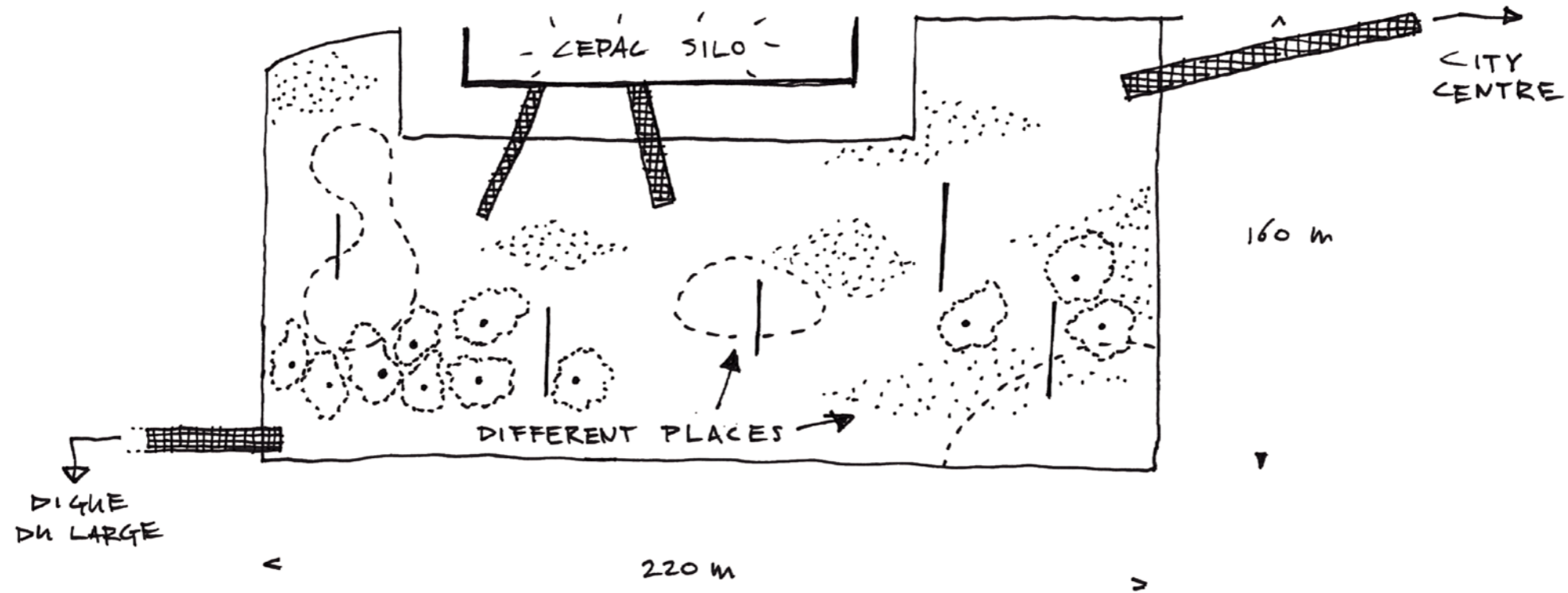
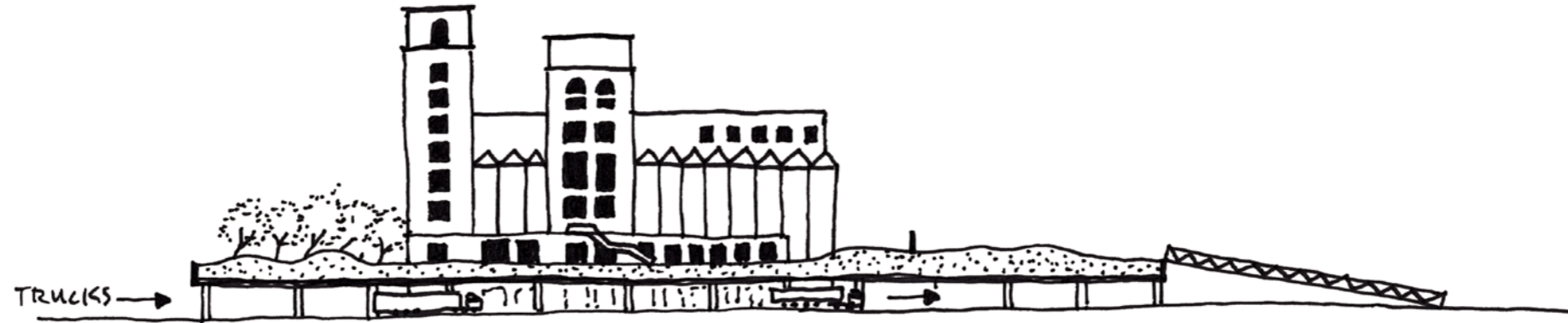

1 ENTRANCE

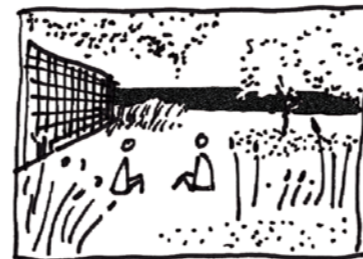

2 LOOSE THE CITY



3 SCENERY





MONTE D'ORO  
RASTIA



**a stroll in two cities**



# a stroll in two cities

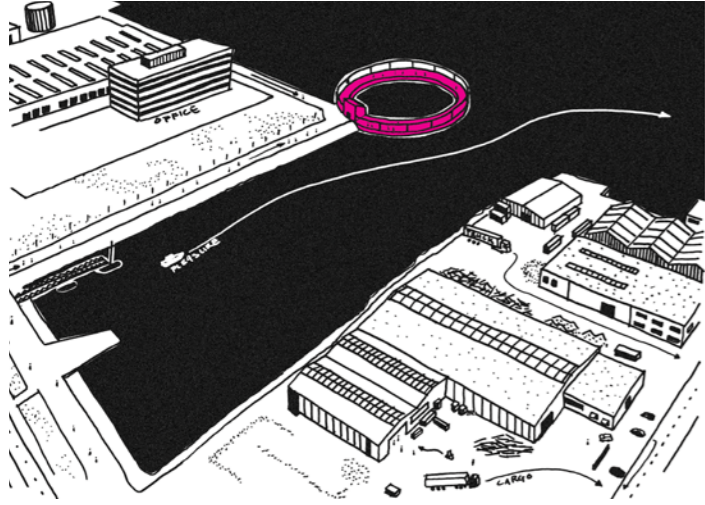

11:00h

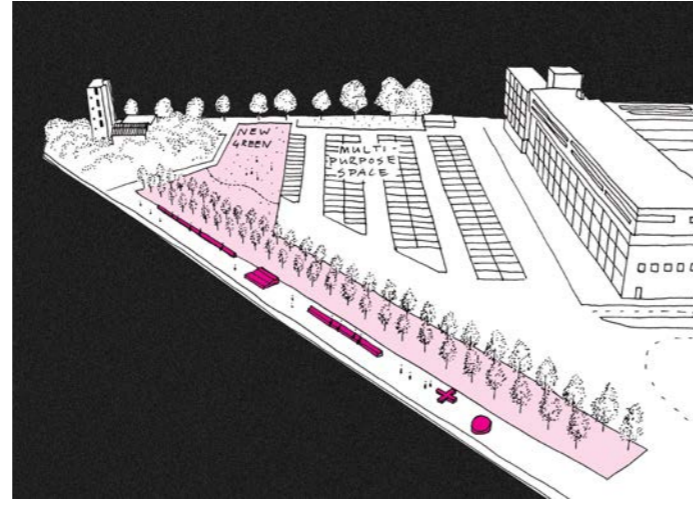

14:00h

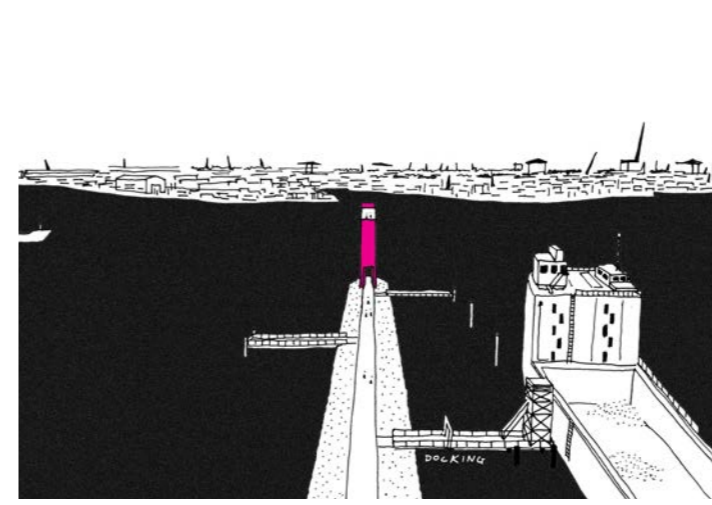

19:00h

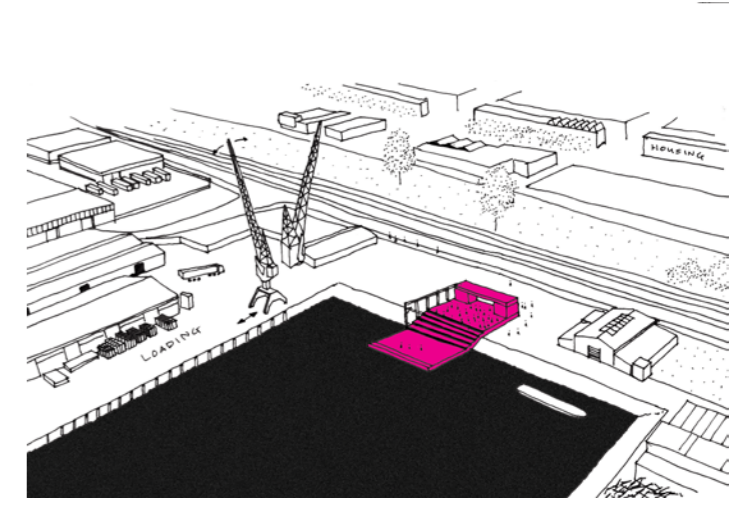

21:30h

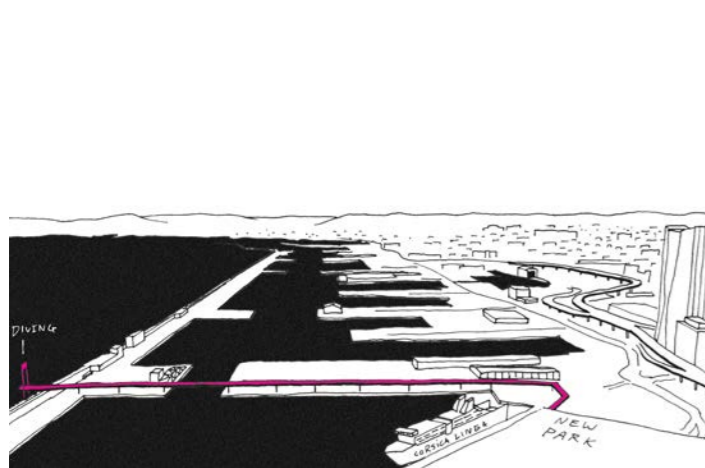

11:00h

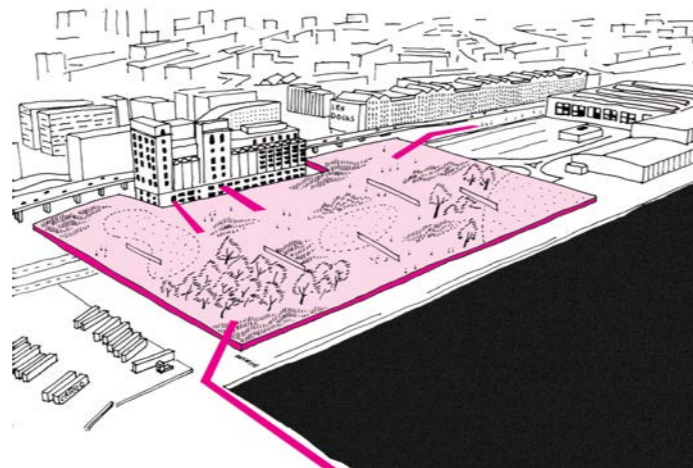

14:00h

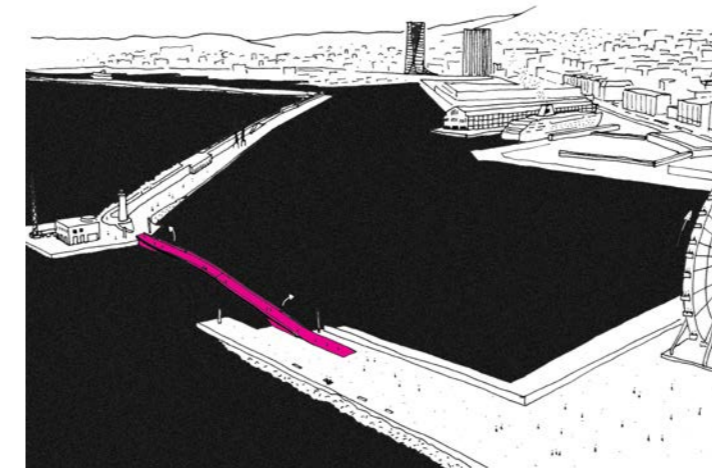

19:00h

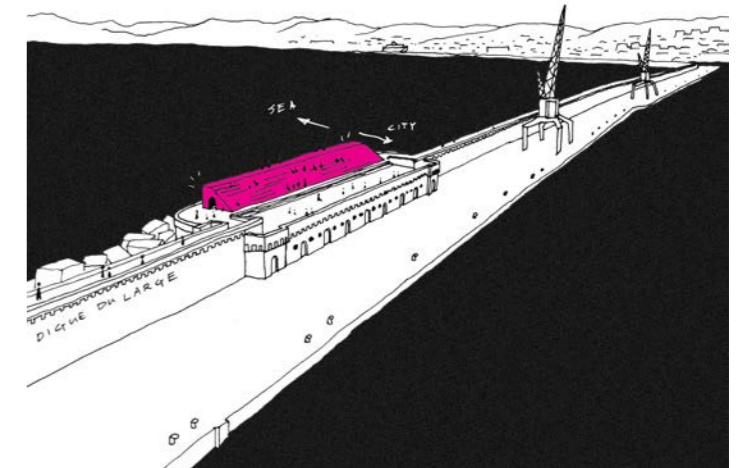

21:30h



# a stroll in two cities



11:00h



14:00h

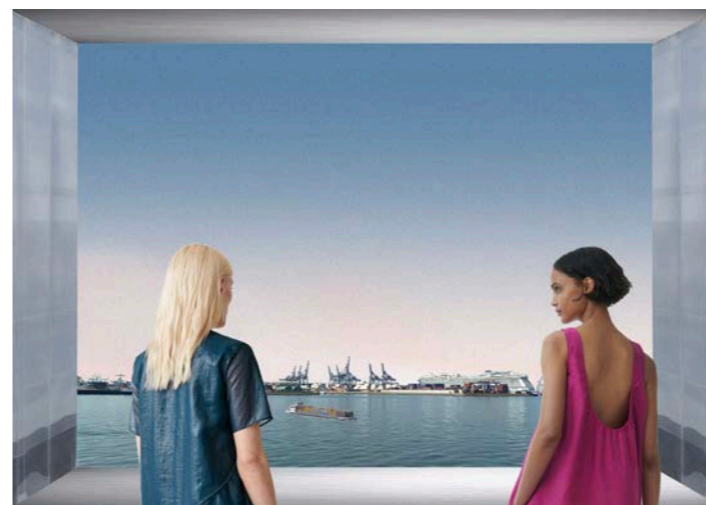

19:00h



21:30h



11:00h



14:00h



19:00h

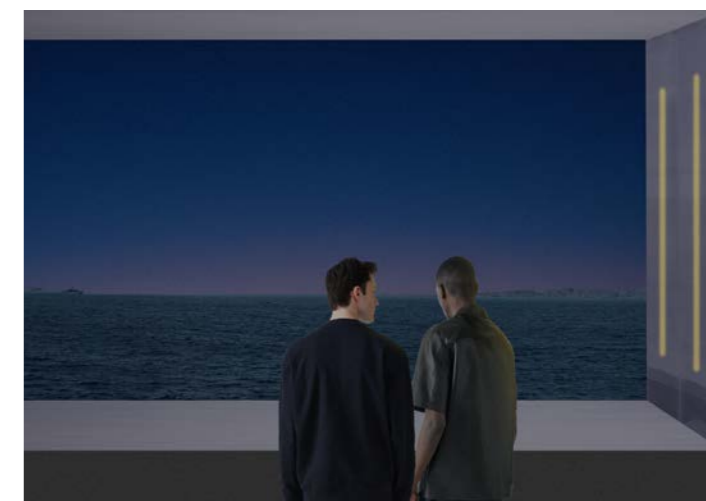

21:30h



**love the city ♥ embrace the port**