

HUIS I 10x10x10

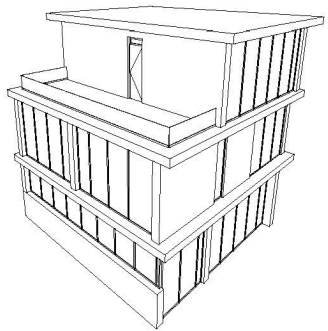

HUIS II zonder ramen

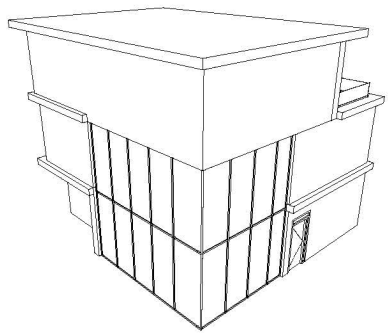
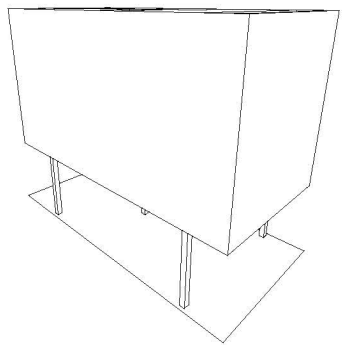
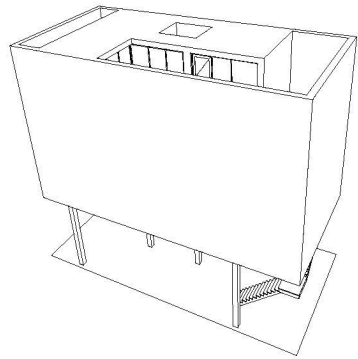

HUIS III Zwembad

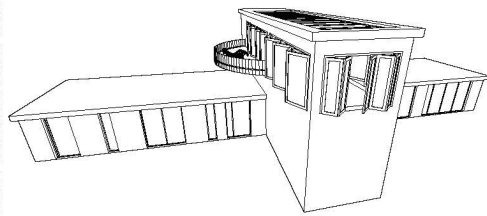
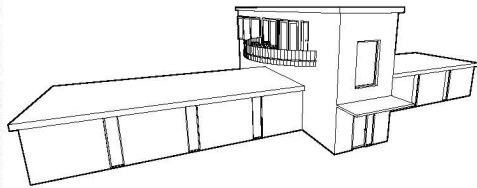

HUIS IV Boekenkast

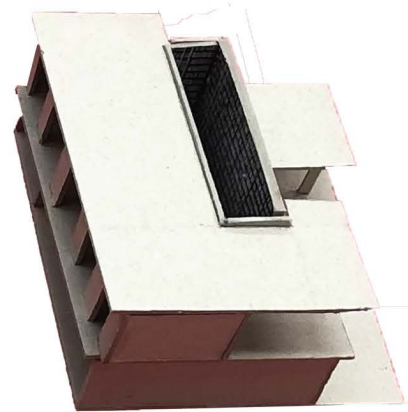
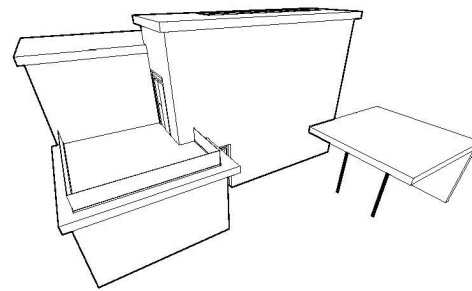
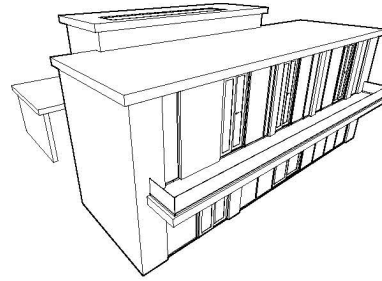

HUIS V Zonder gang

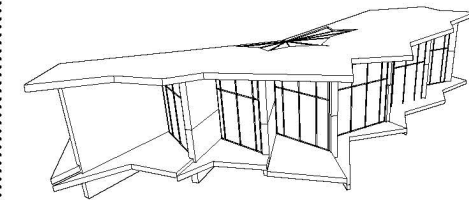
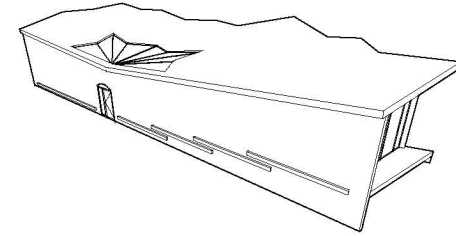

HUIS VI StoryBoard.

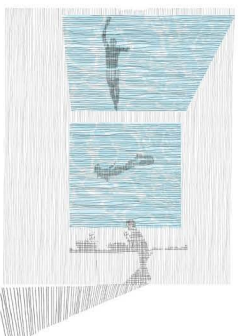
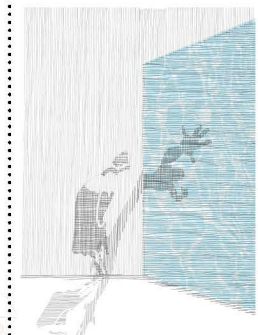
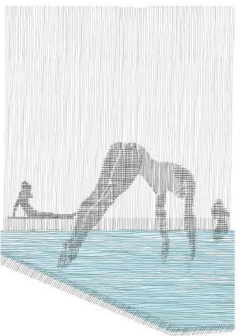

Elementair ontwerpen

1e opgave:

Het huis past in een kubus van 10 m x 10 m x 10 m en raakt tenminste éénmaal aan alle vlakken van die kubus.

Concept: Buiten is Binnen

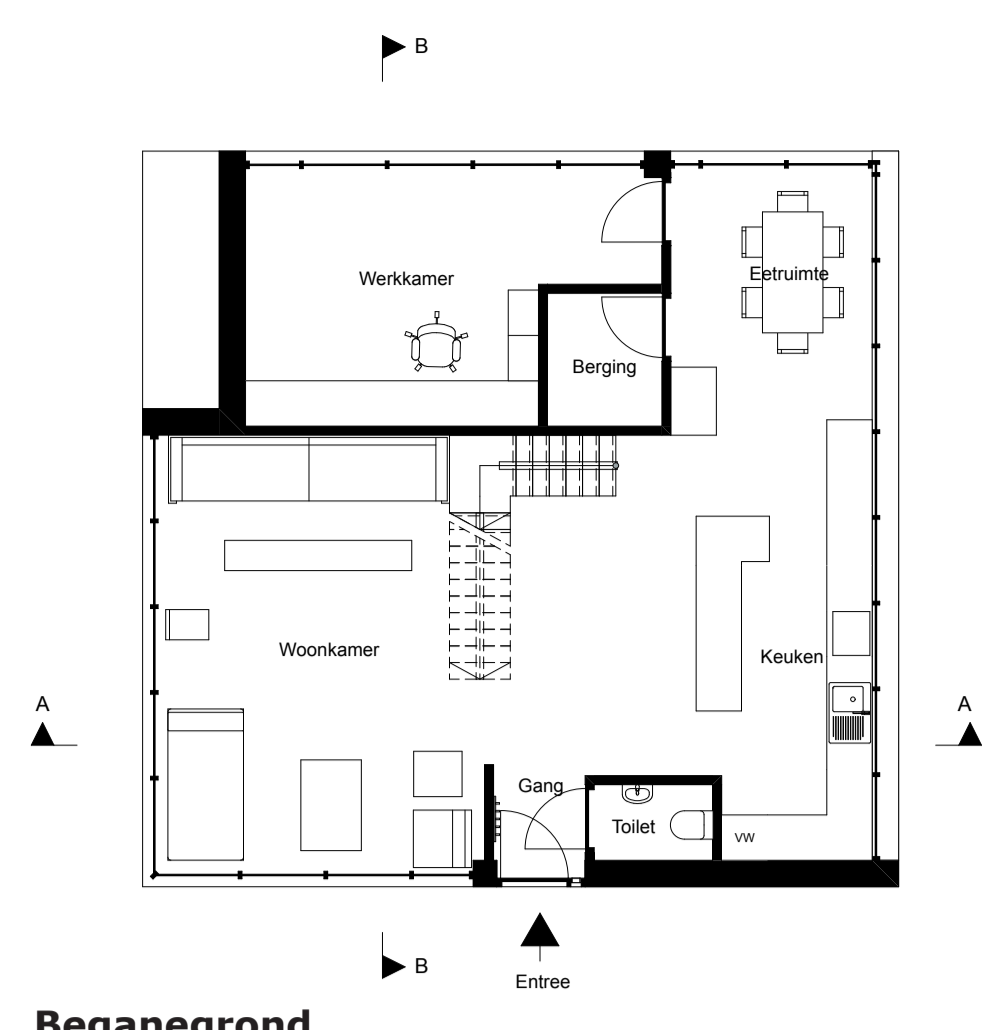

Beganegrond

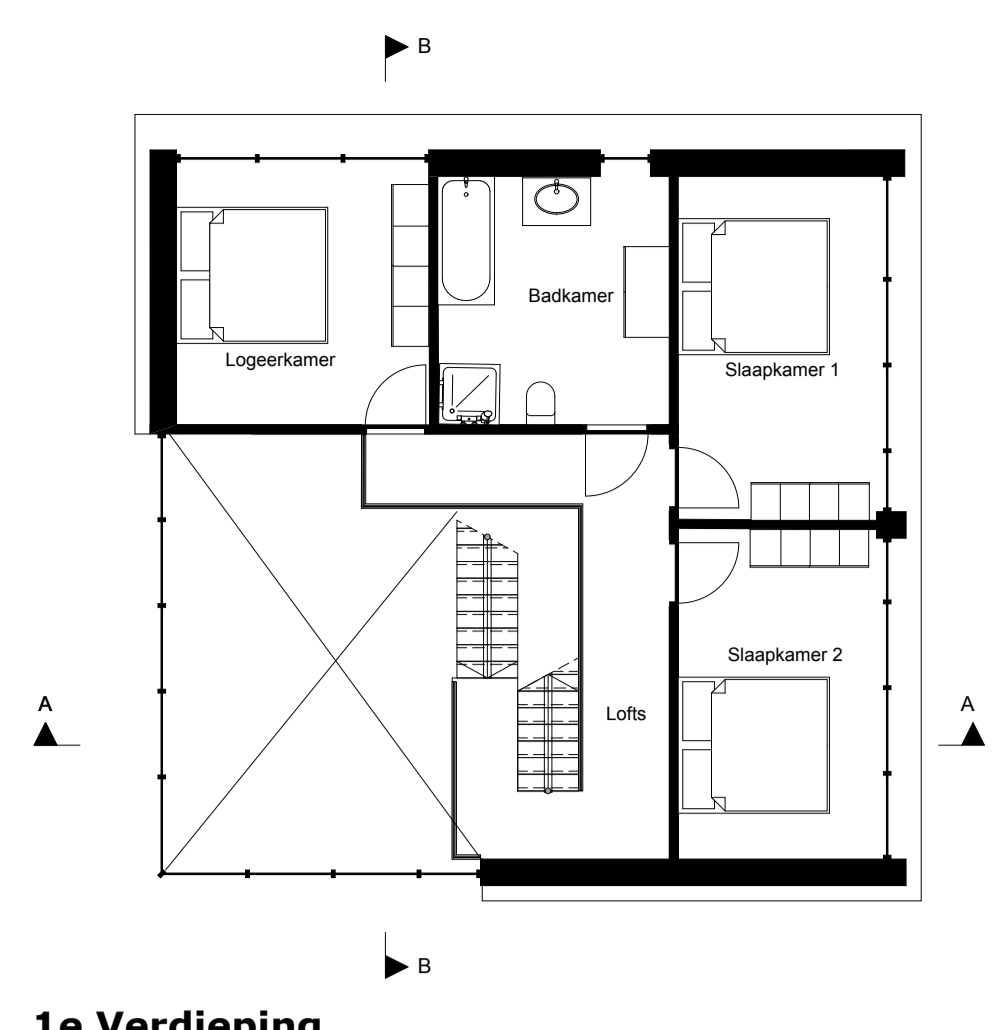

1e Verdieping

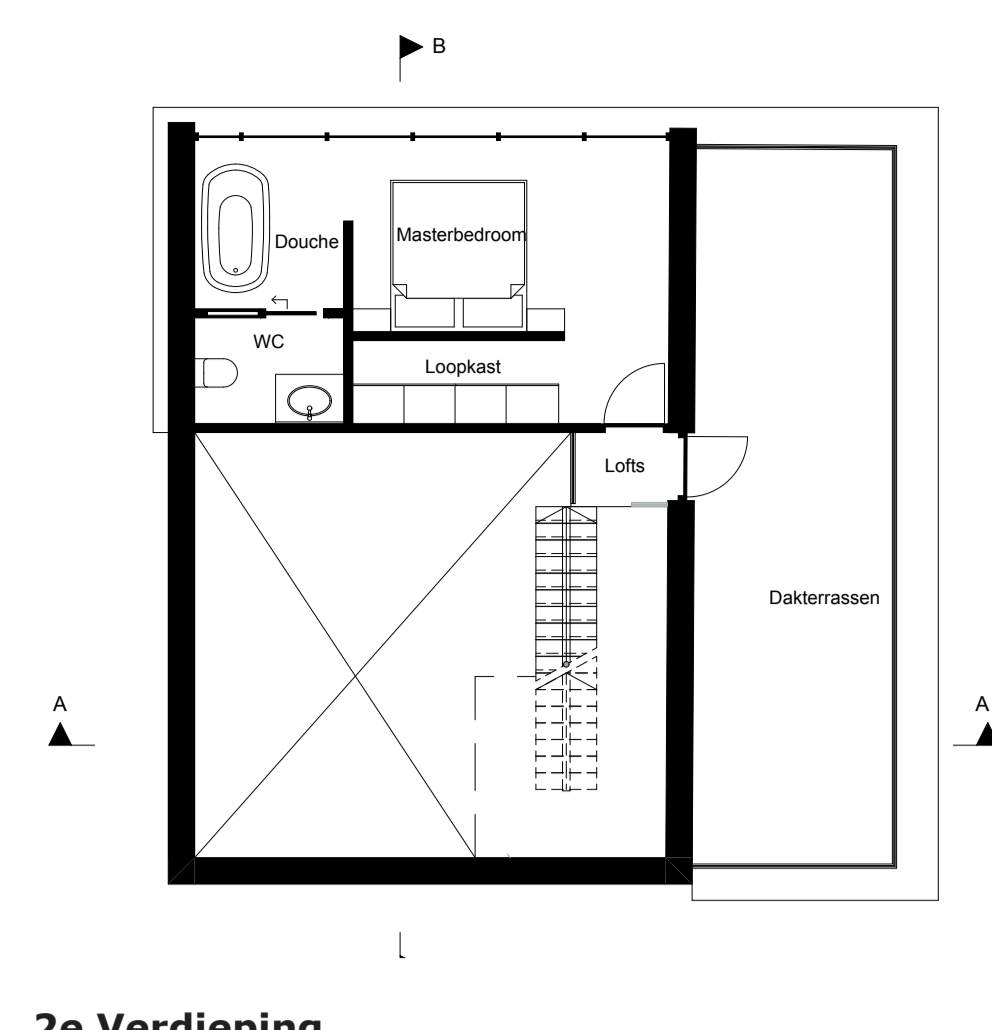

2e Verdieping

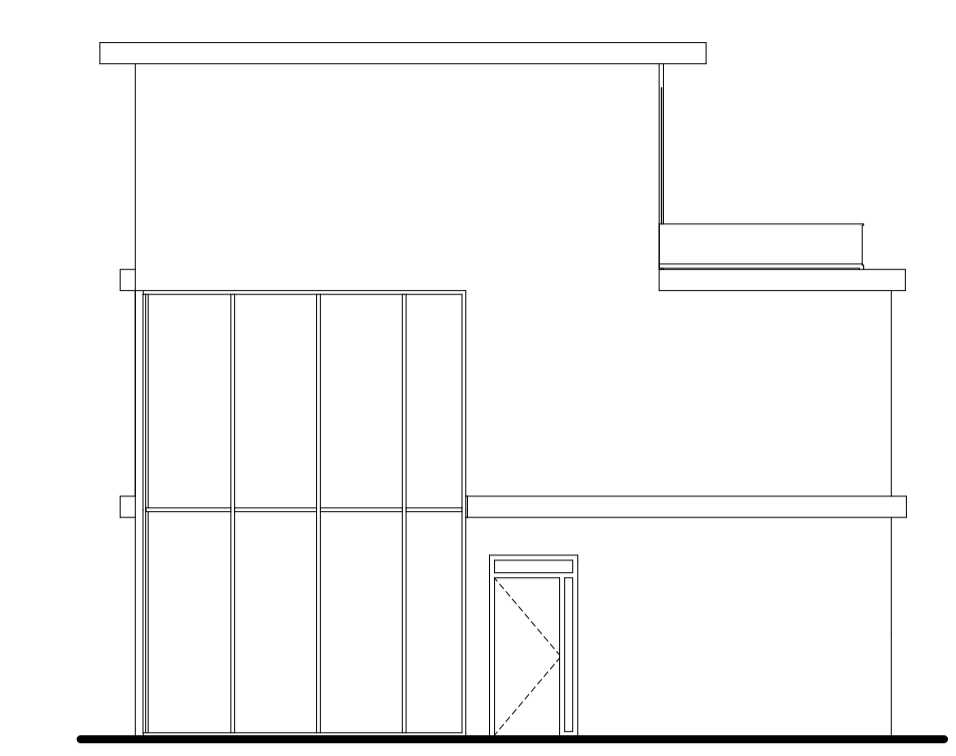

Voorgevel

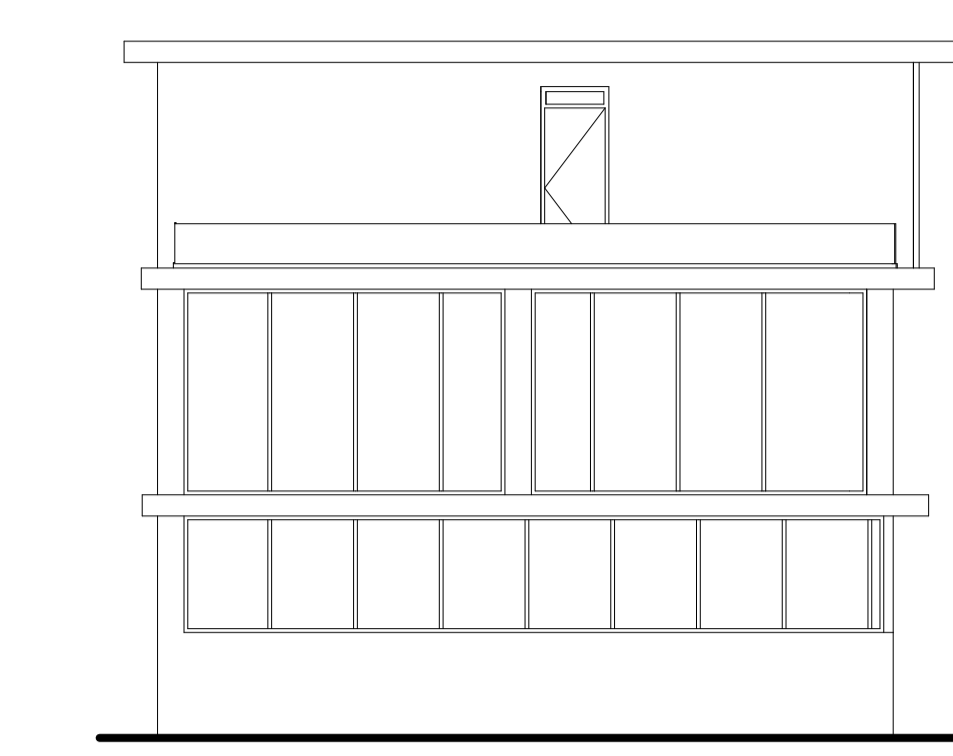

Rechter zijgevel

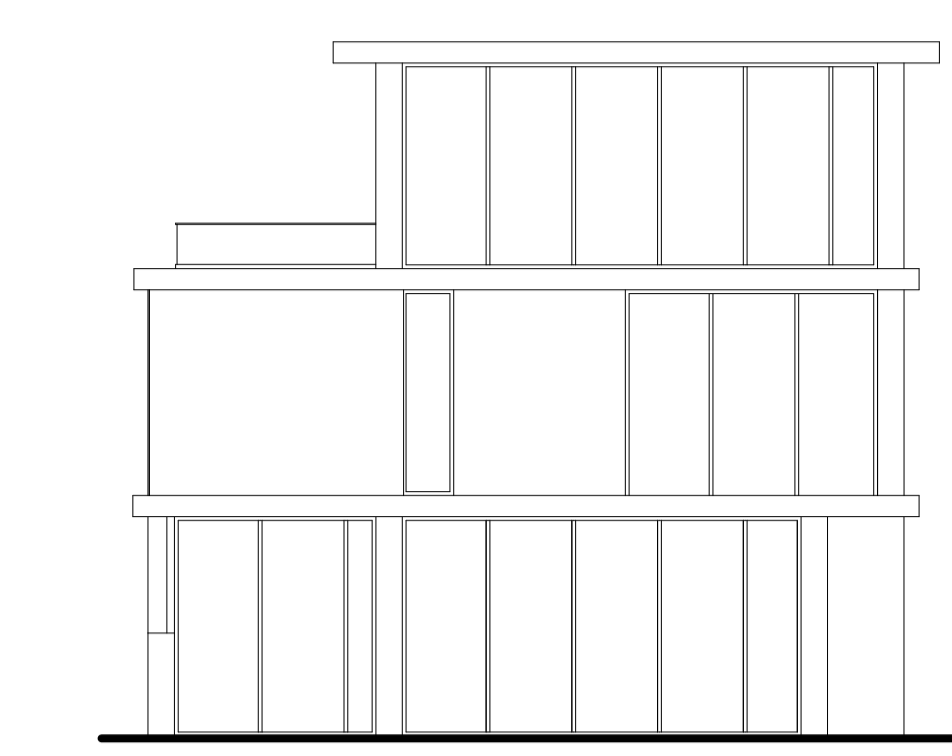

Achtergevel

2e opgave:

Het huis heeft geen openingen aan de buitenkant, op de voordeur na, die zich op 4,75 meter boven het maaiveld bevindt.

Concept: Patio huis

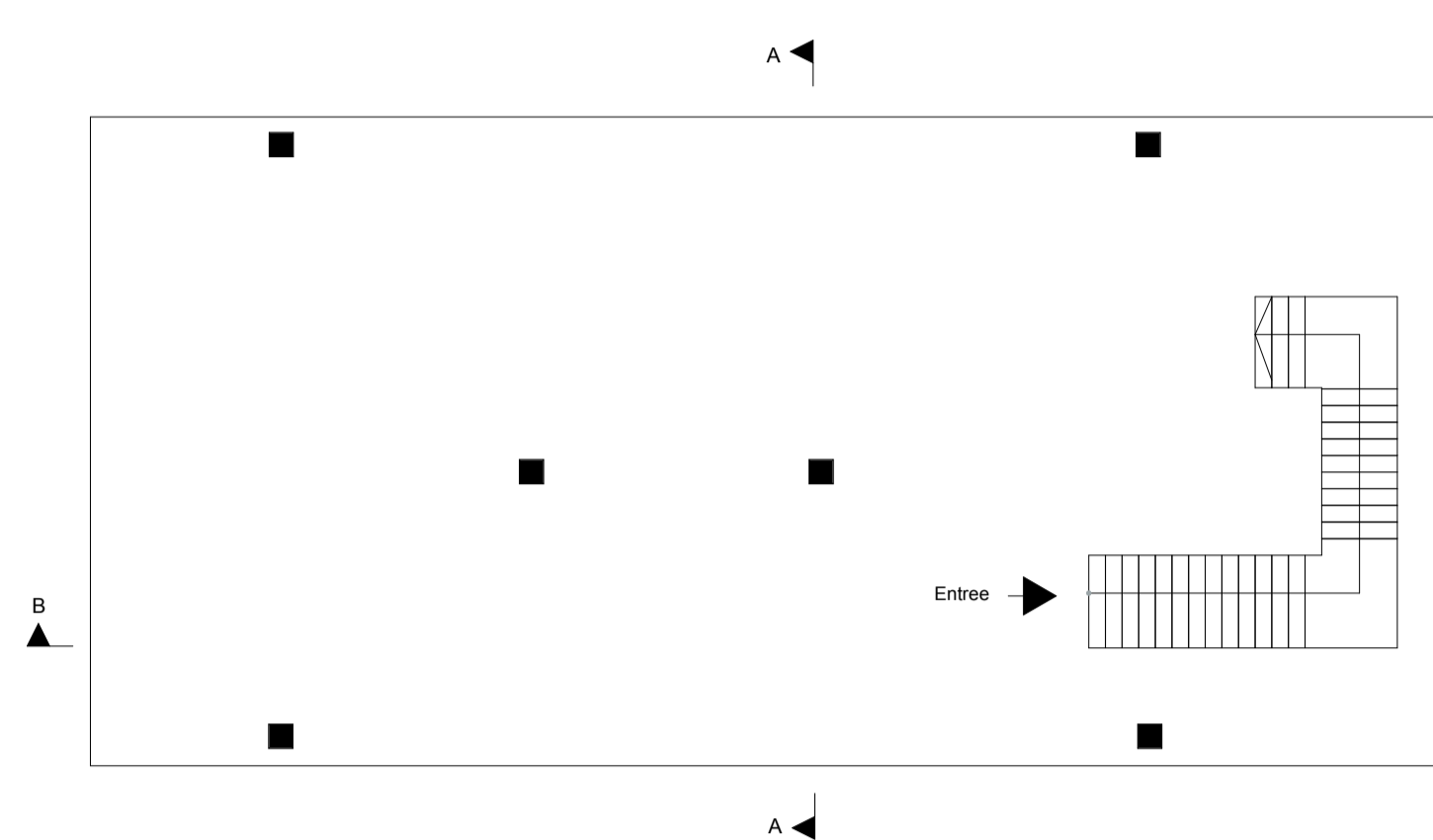

Beganegrond

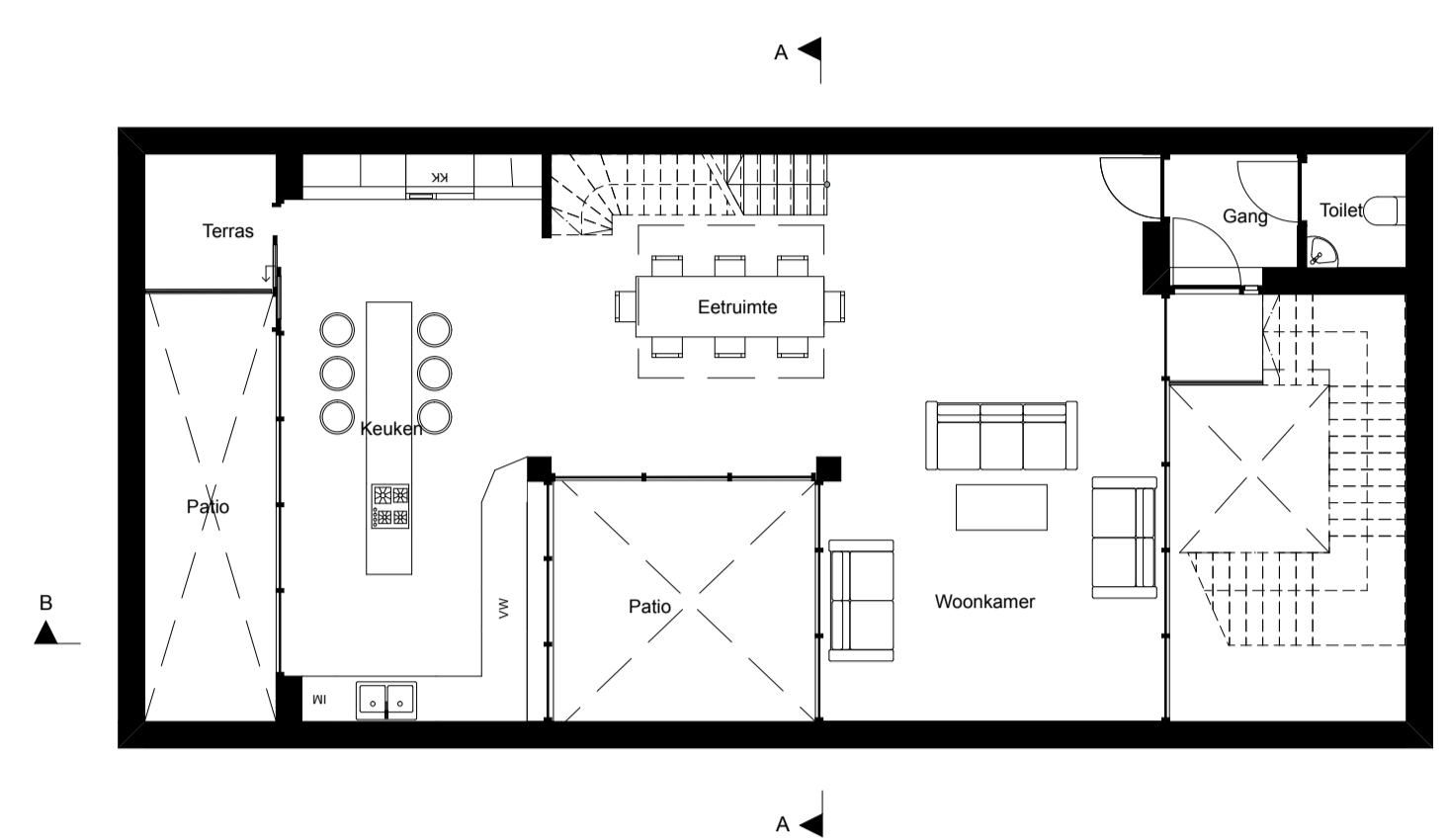

1e Verdieping

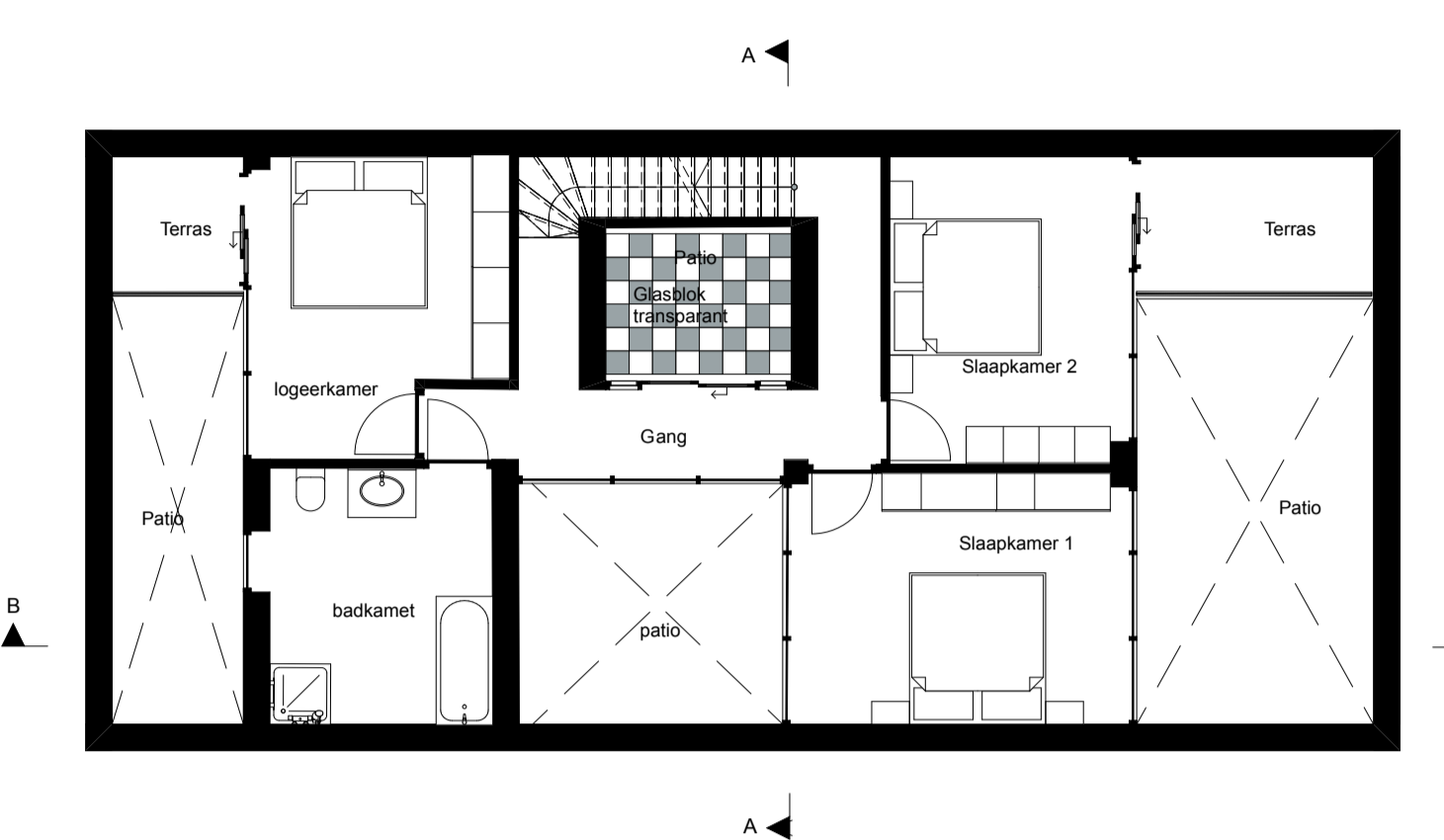

2e Verdieping

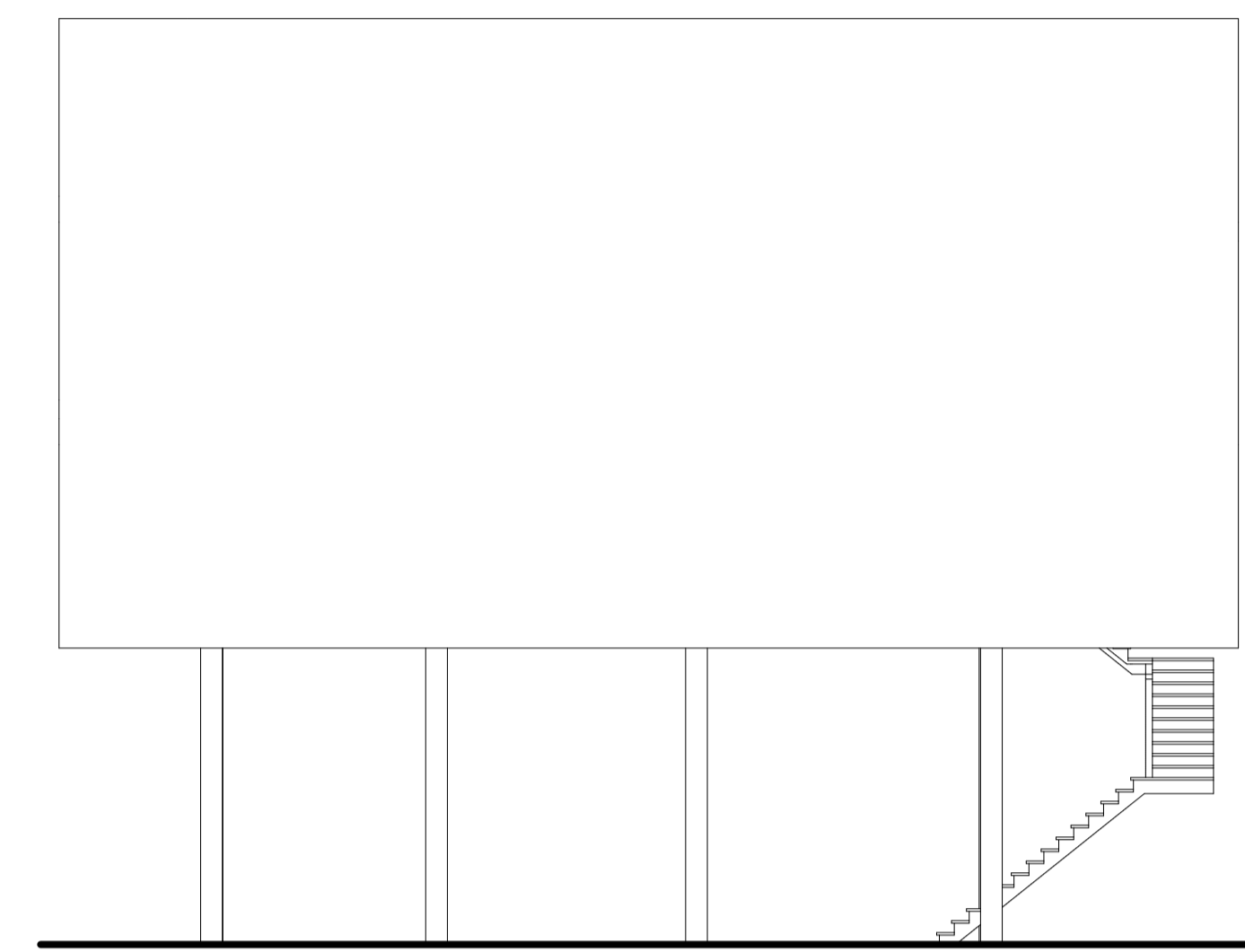

Voorgevel

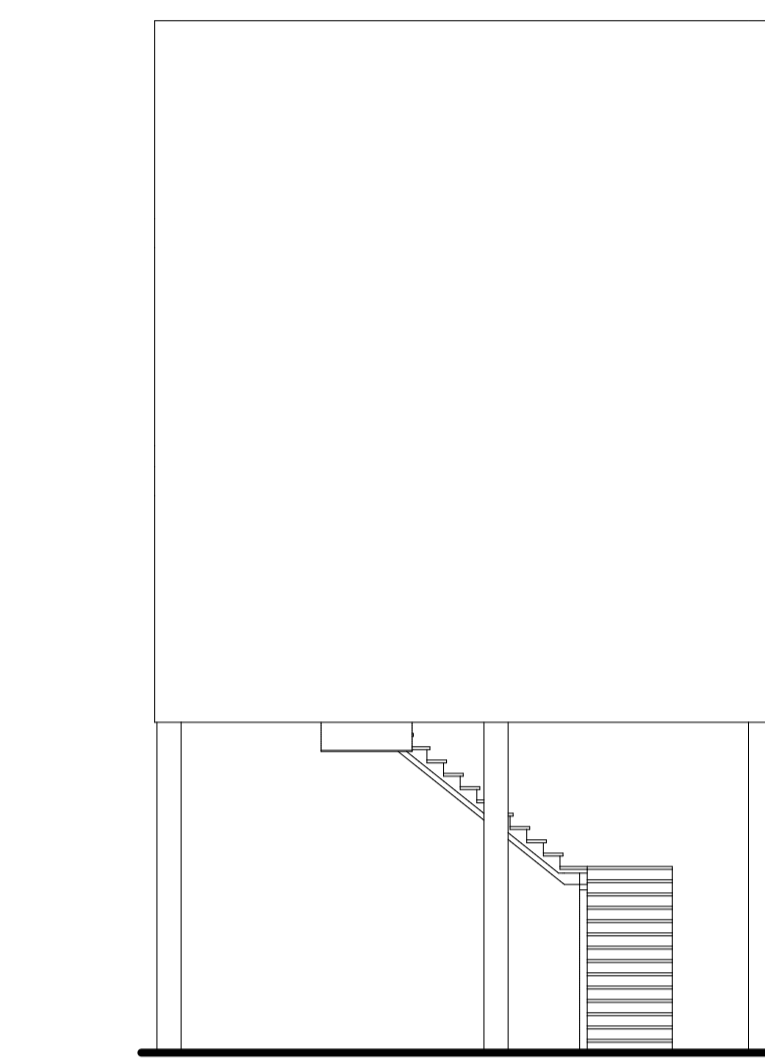

Rechter zijgevel

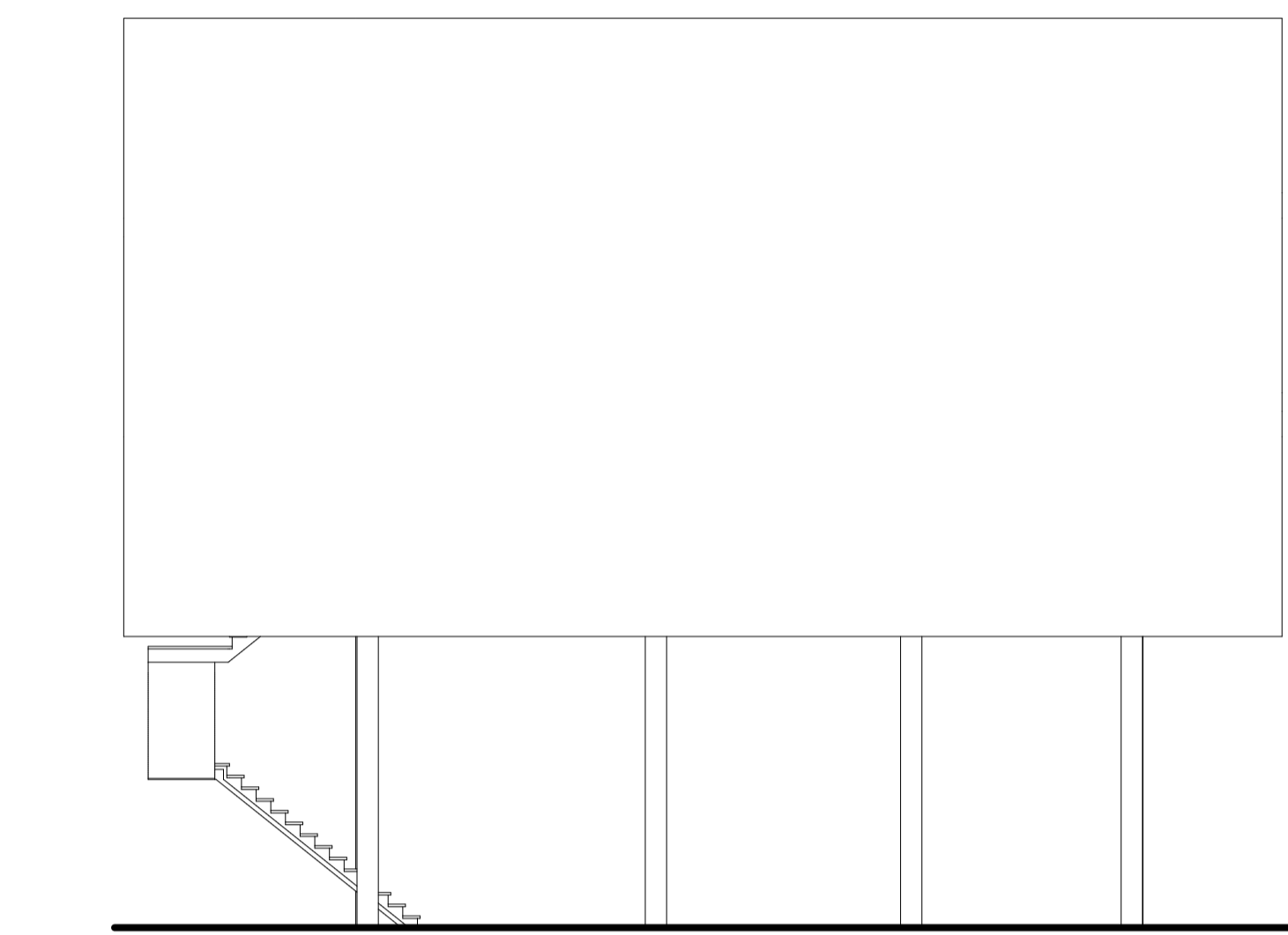

Achterevel

3e opgave:

Het huis heeft een zwembad van 12,5 x 3 meter.

Concept: Blauwe wereld

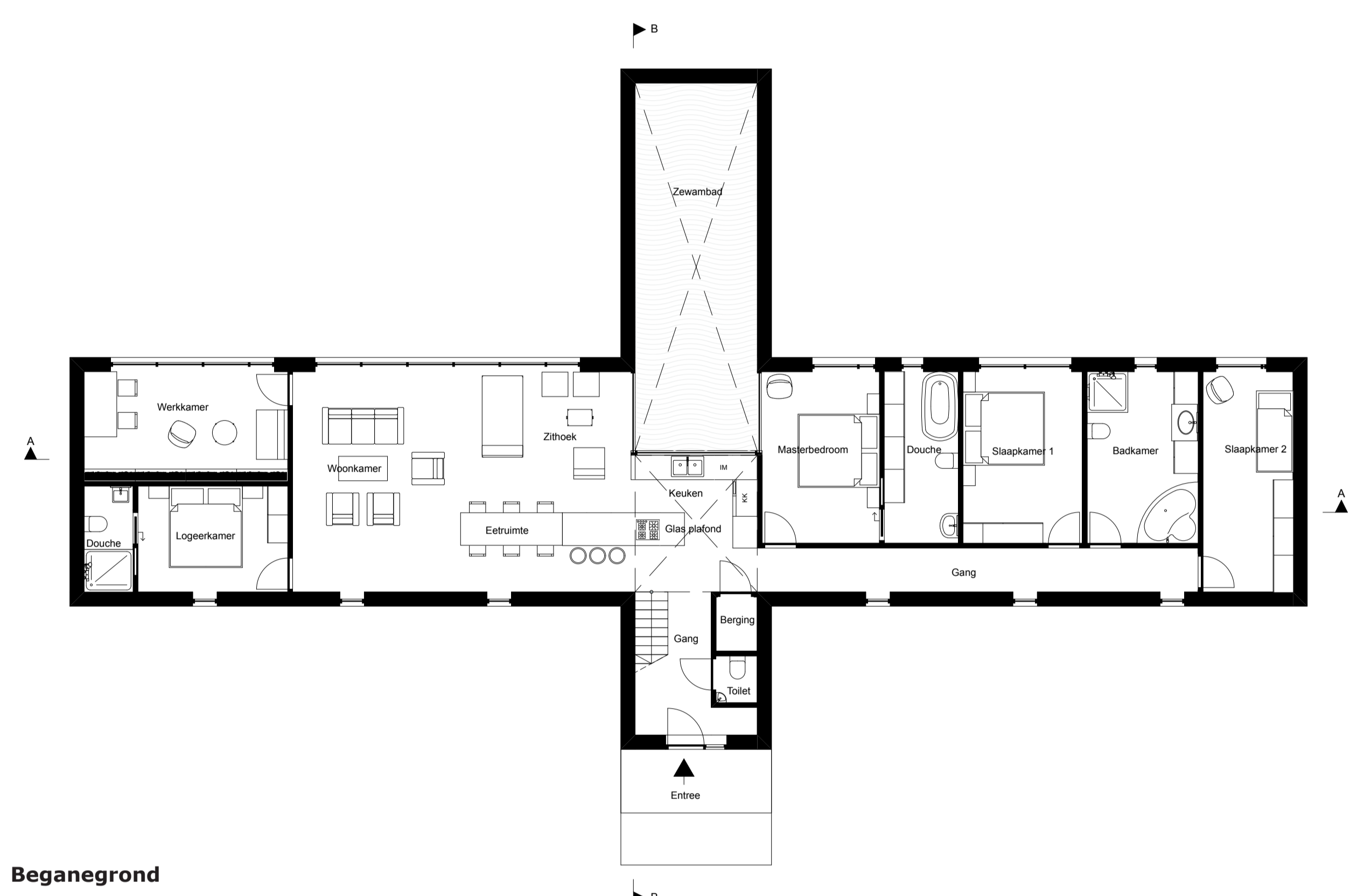

Beganegrond

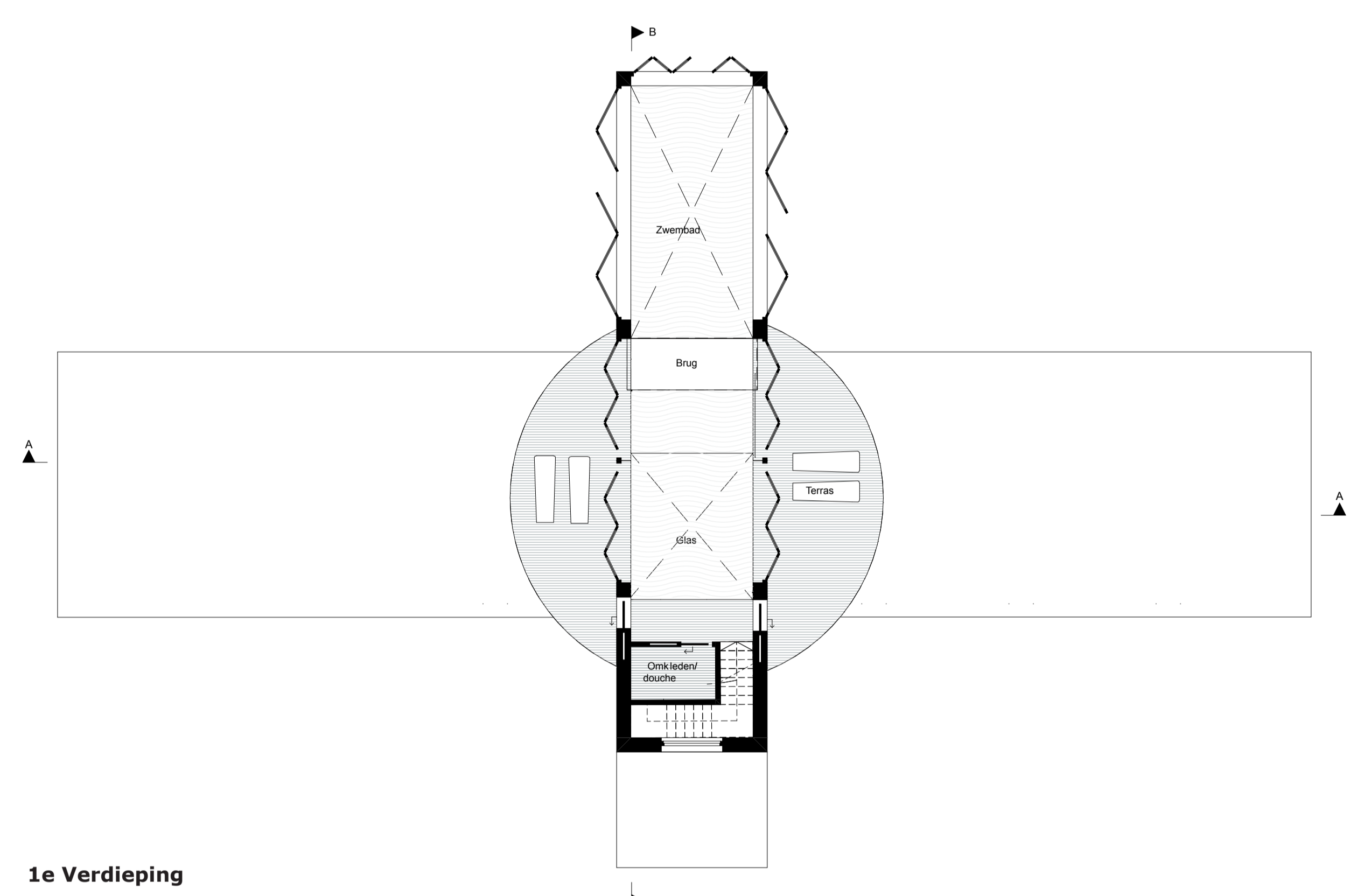

1e Verdieping

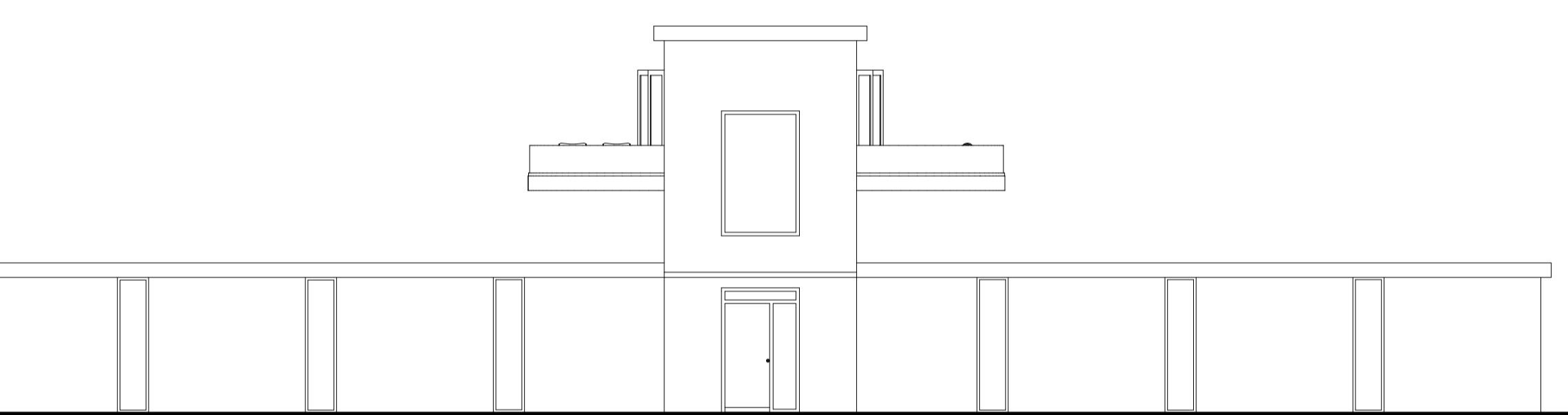

Voorgevel

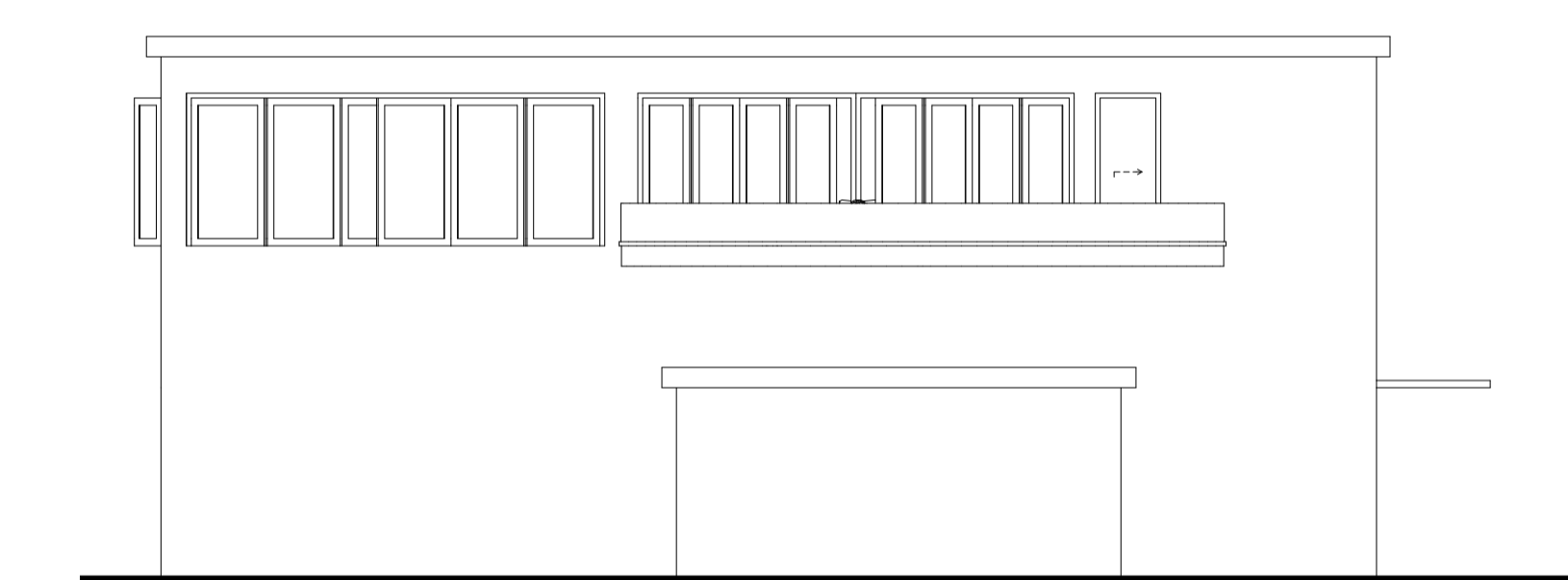

Linker zijgevel

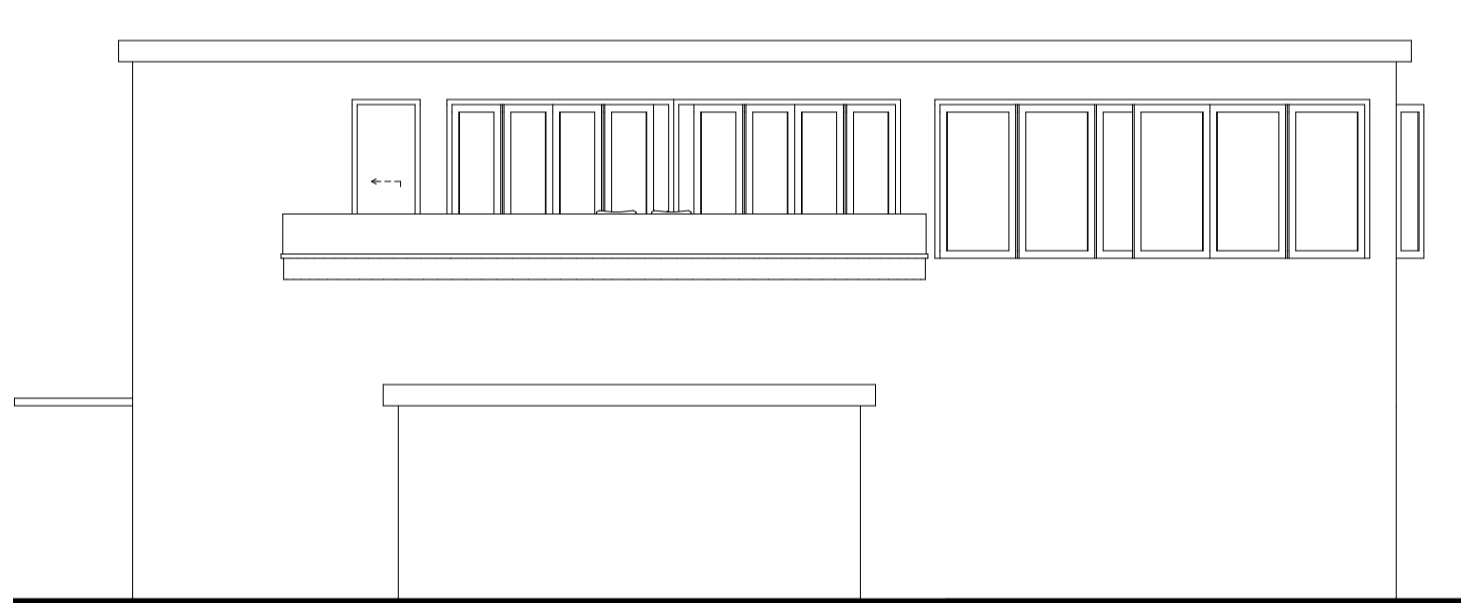

Rechter zijgevel

4e opgave:

In het huis is plek voor 250 strekkende meter boeken, die toegankelijk moeten zijn.

Concept: Huisbibliotheek

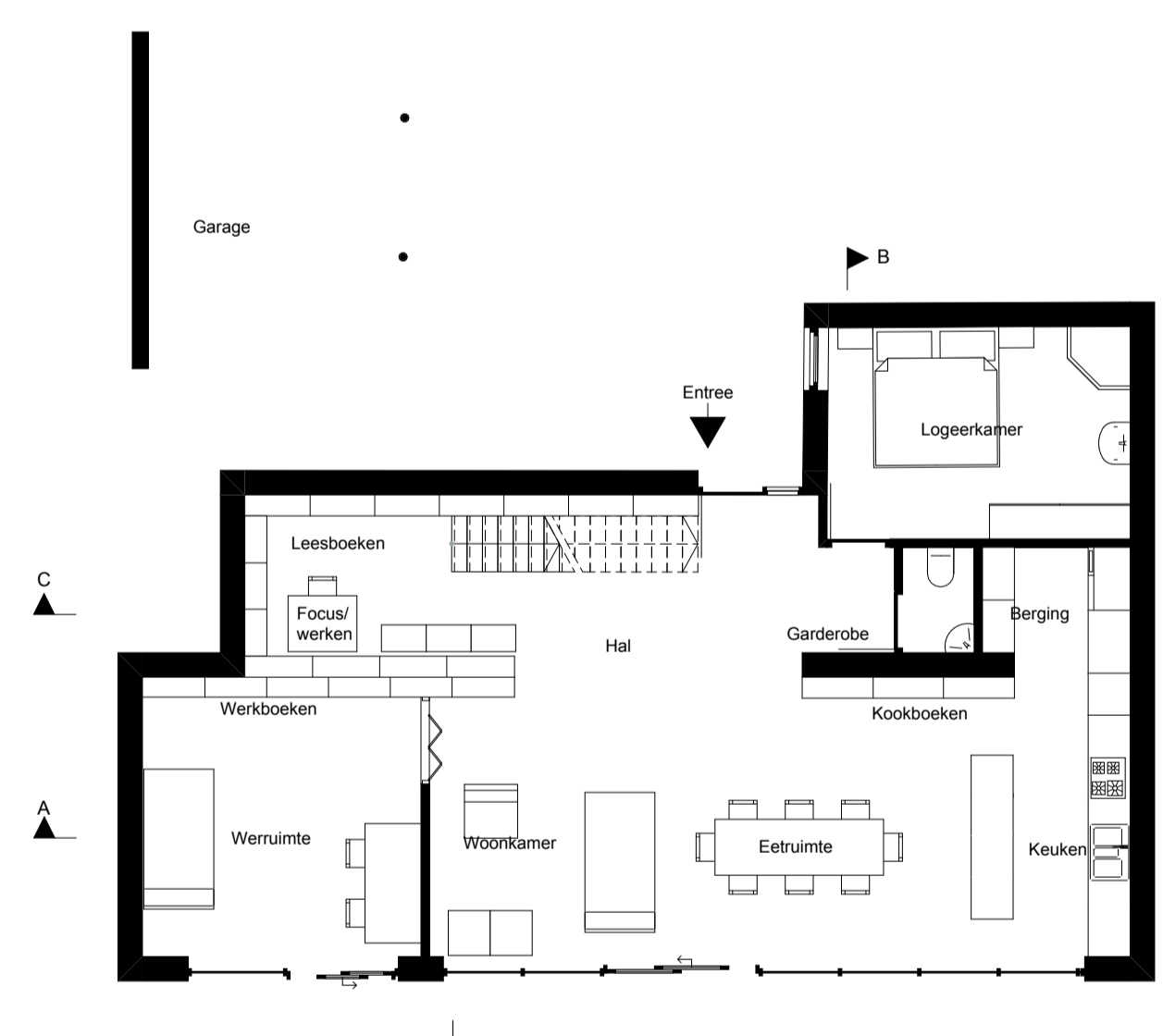

Beganegrond

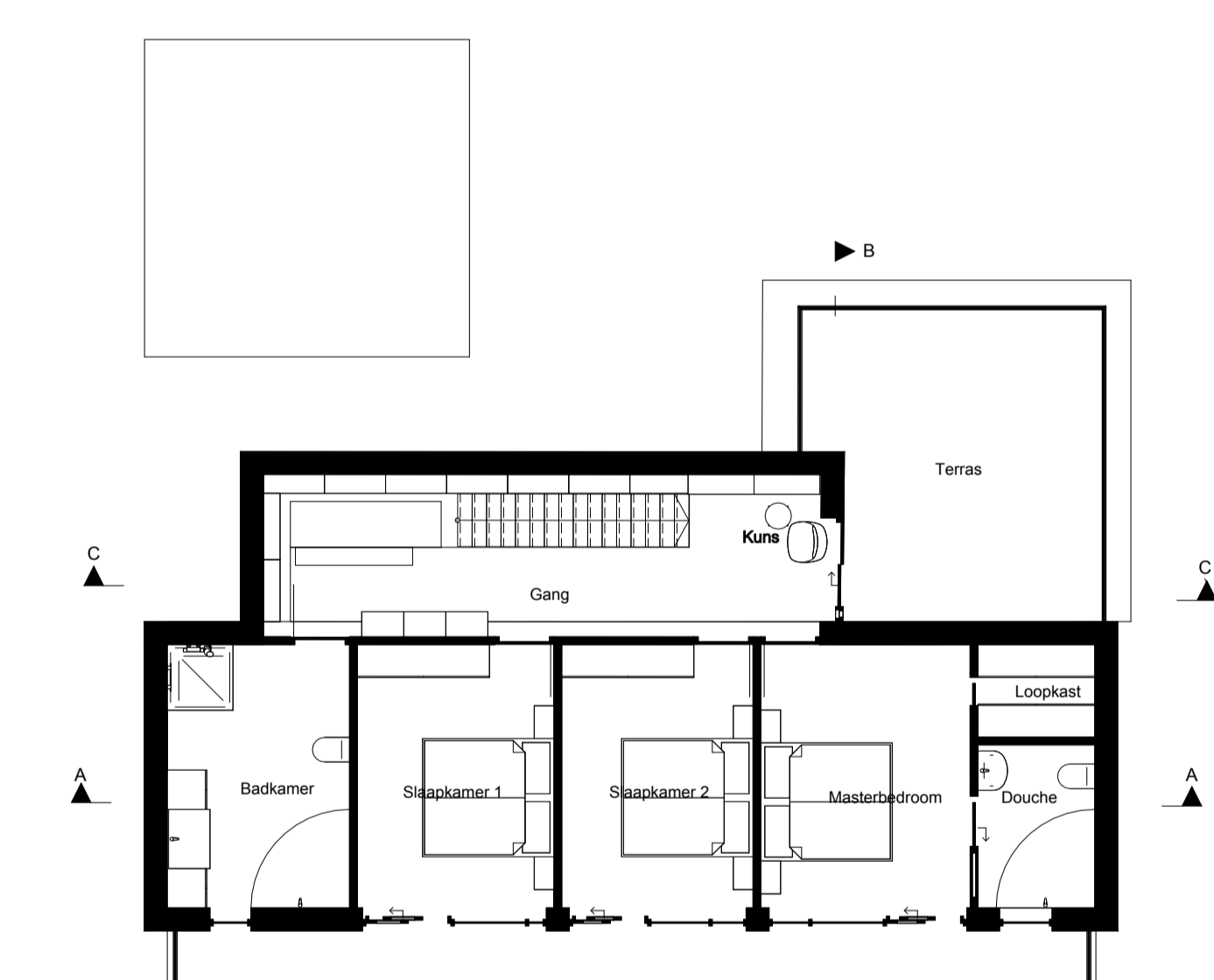

1e Verdieping

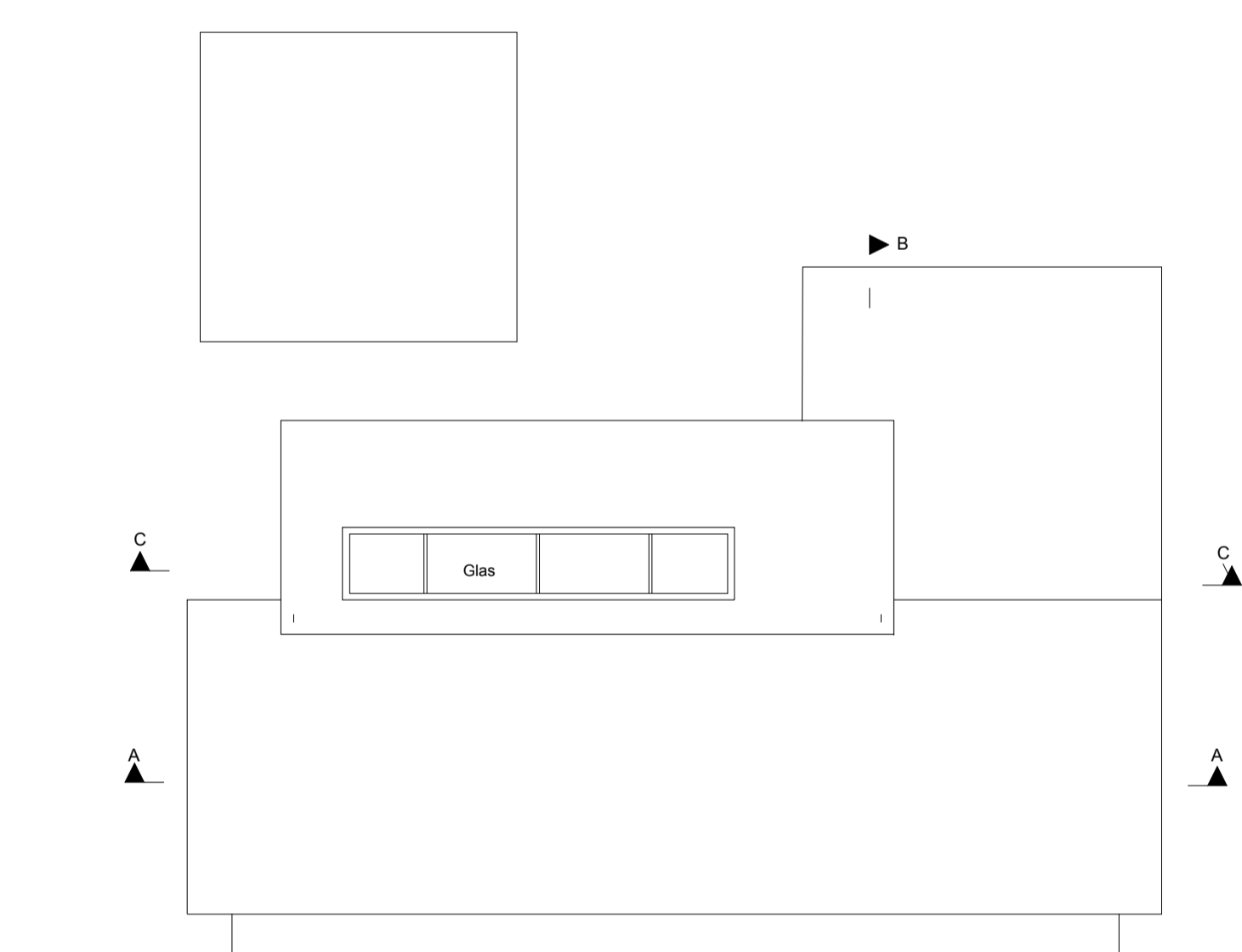

Dakaanzicht

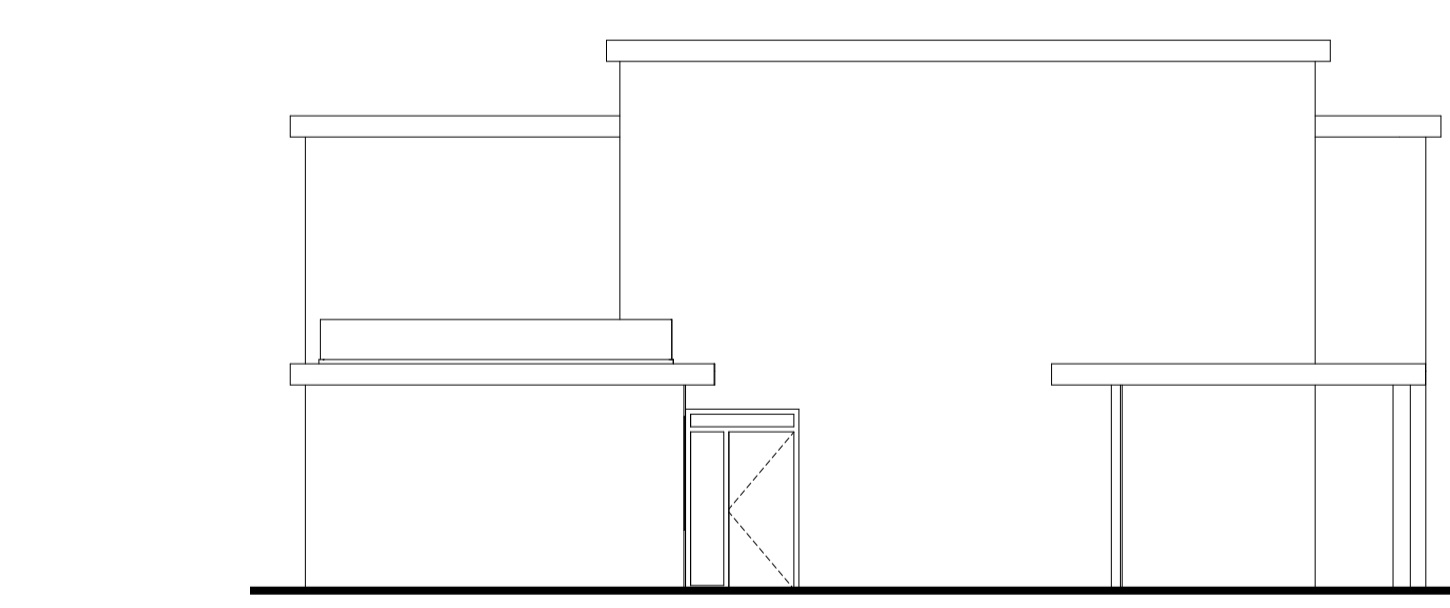

Voorgevel

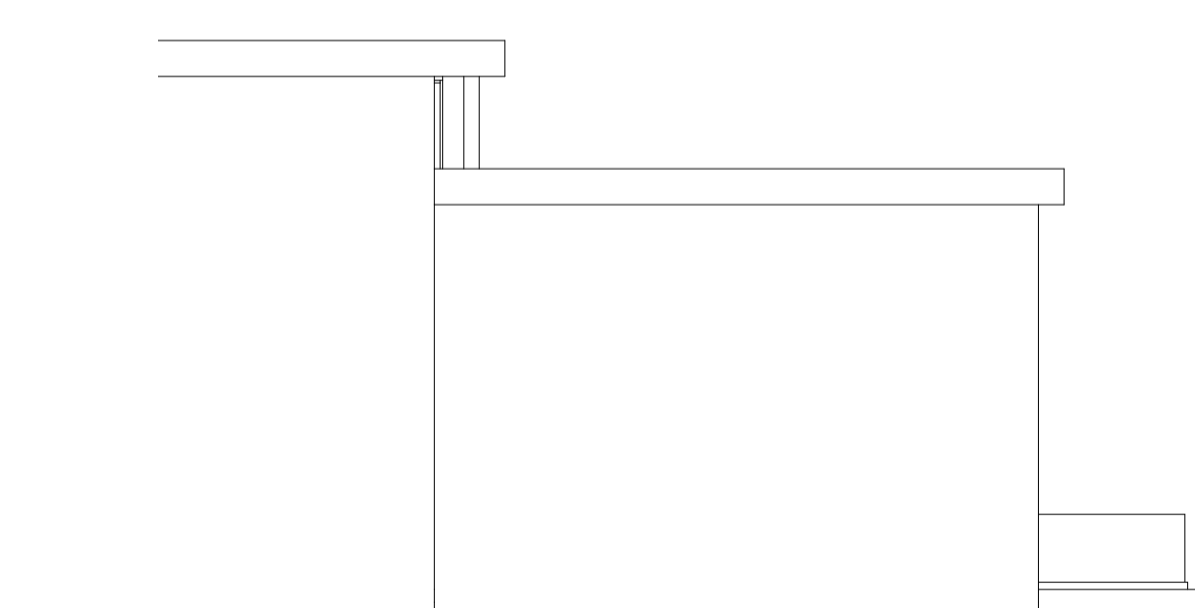

Rechter zijgevel

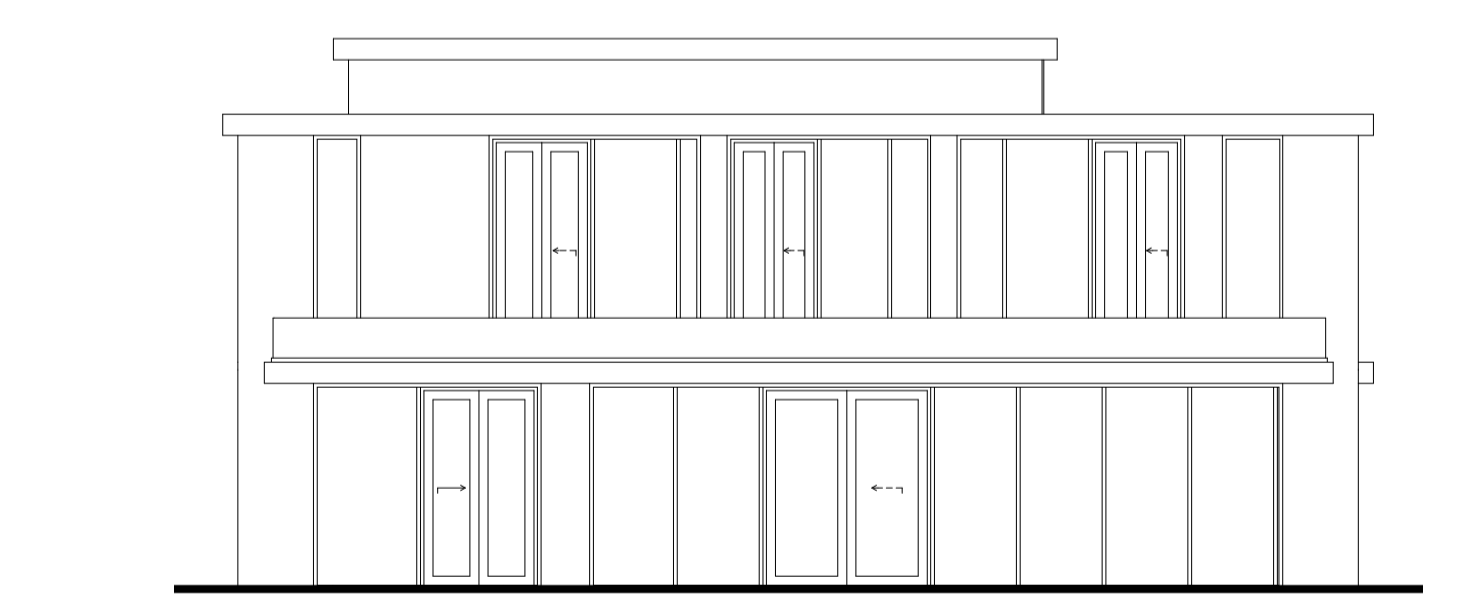

Achterevel

5e opgave:

Het huis heeft geen gang, wel deuren en trappen. Alle ruimten grenzen aan elkaar.

Concept: Het geval (de kwestie) van de trappen (The matter of stairs)

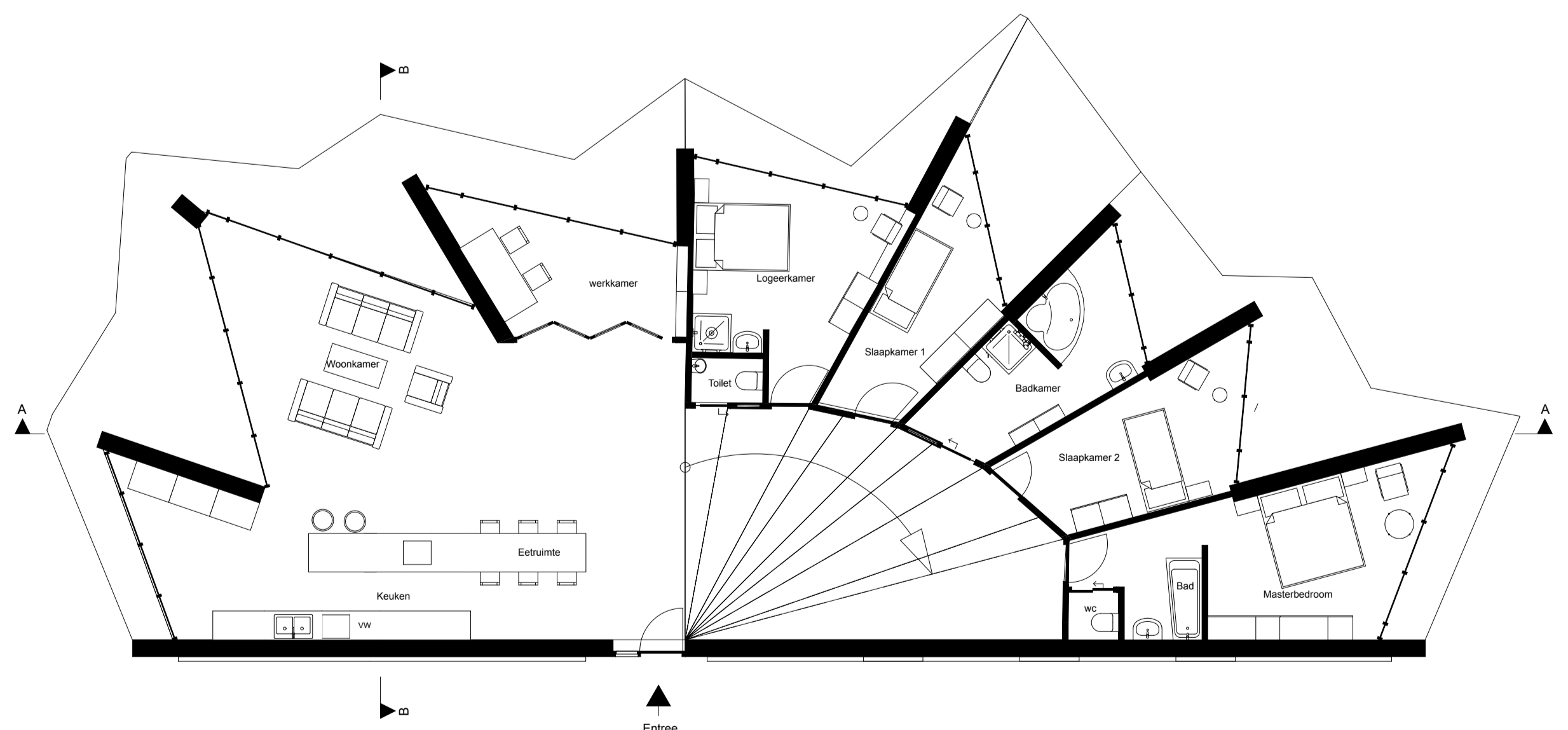

Beganegrond

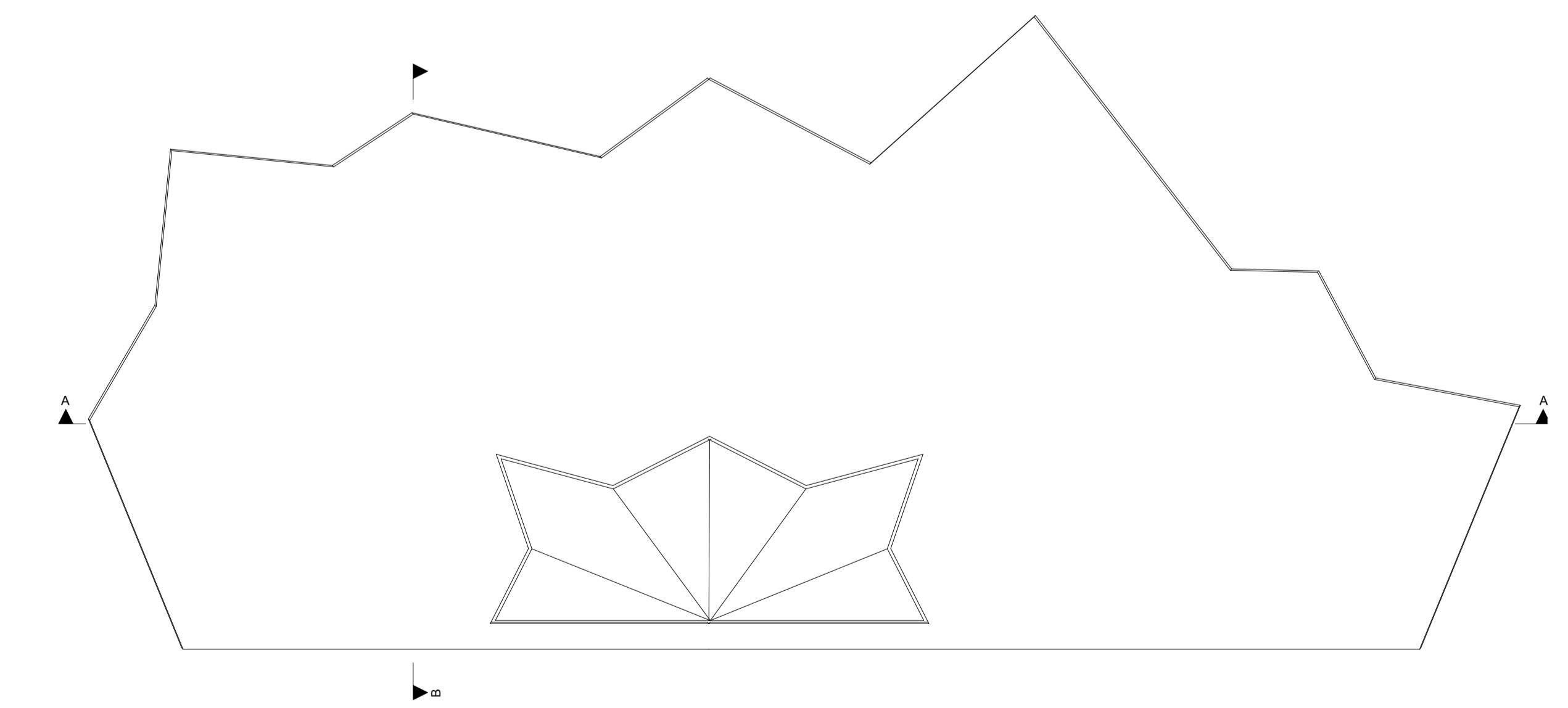

Dakaanzicht

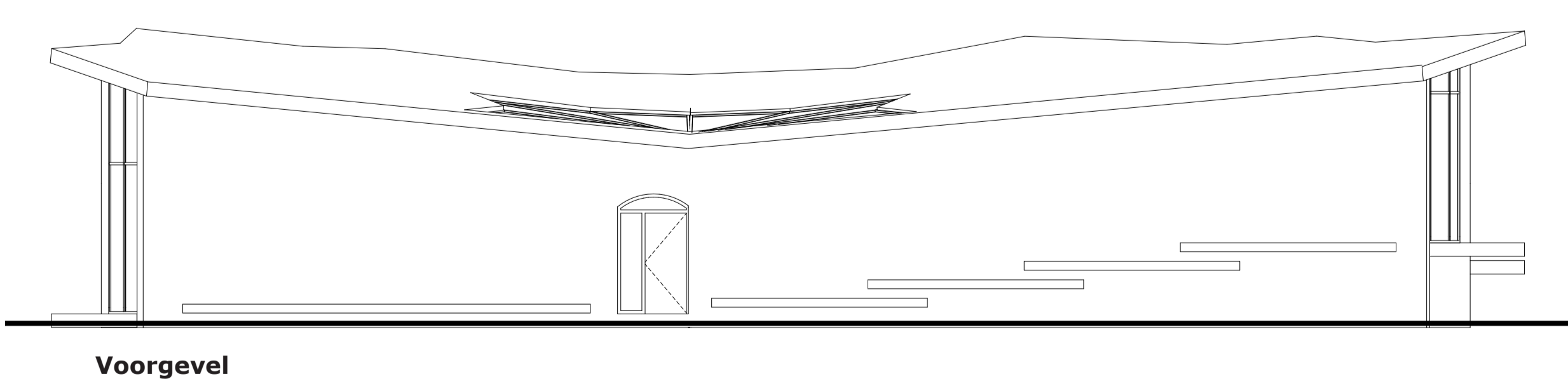

Voorgevel

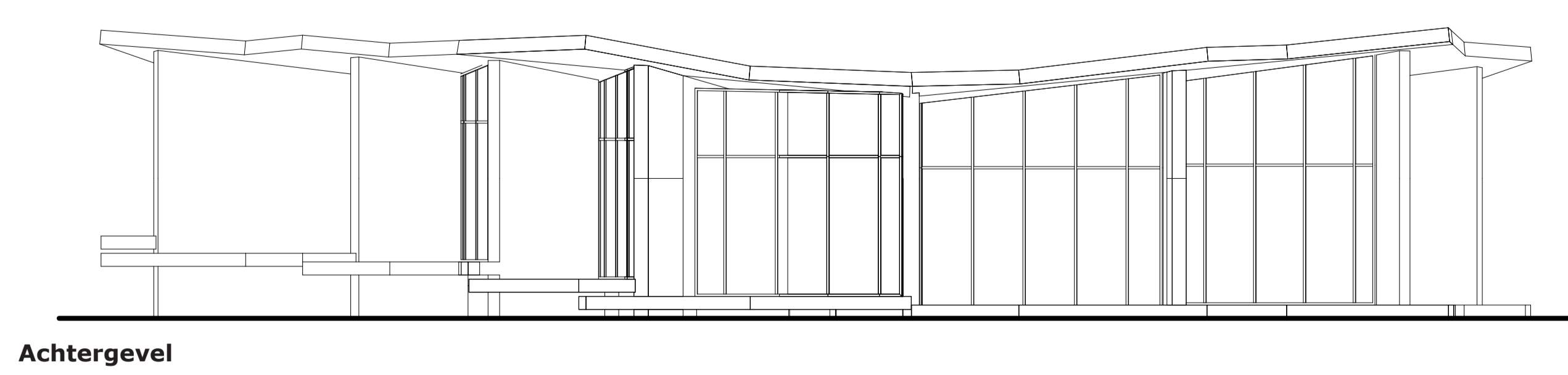

Achterevel

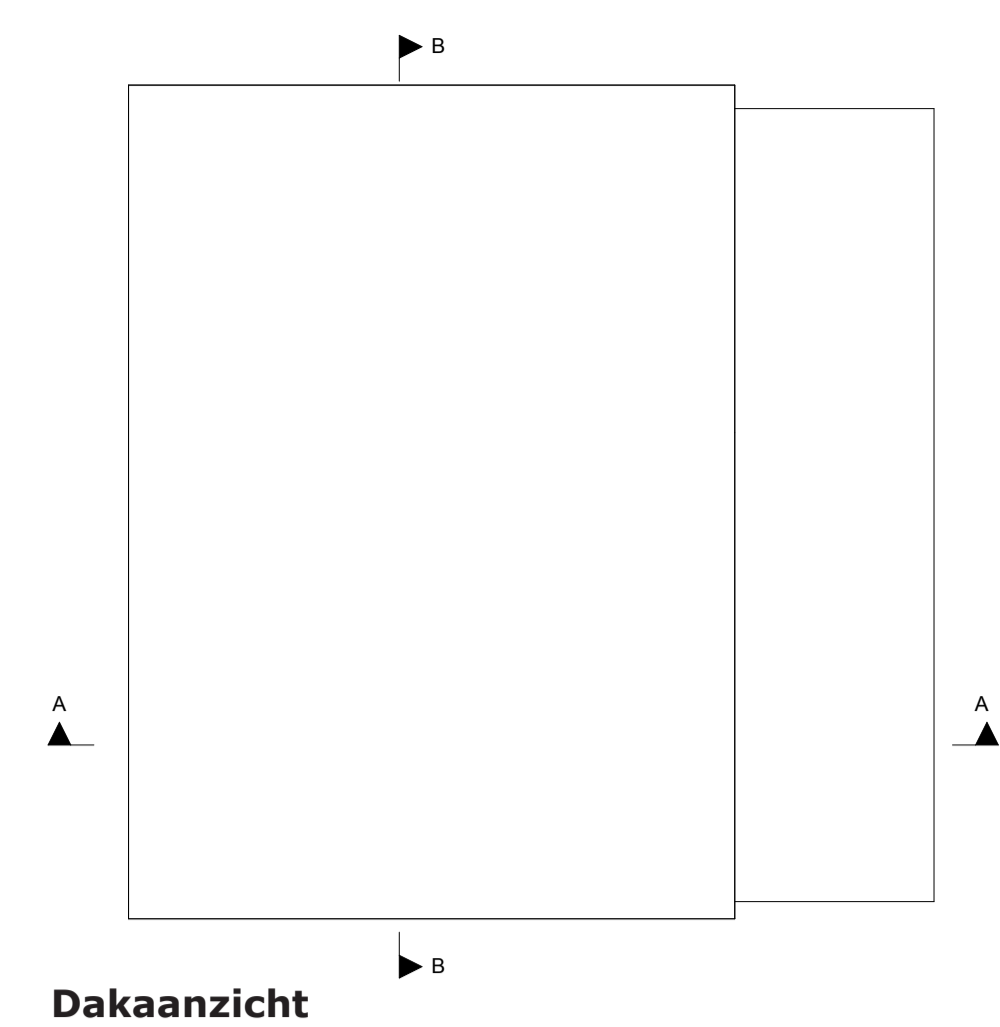

Dakaanzicht

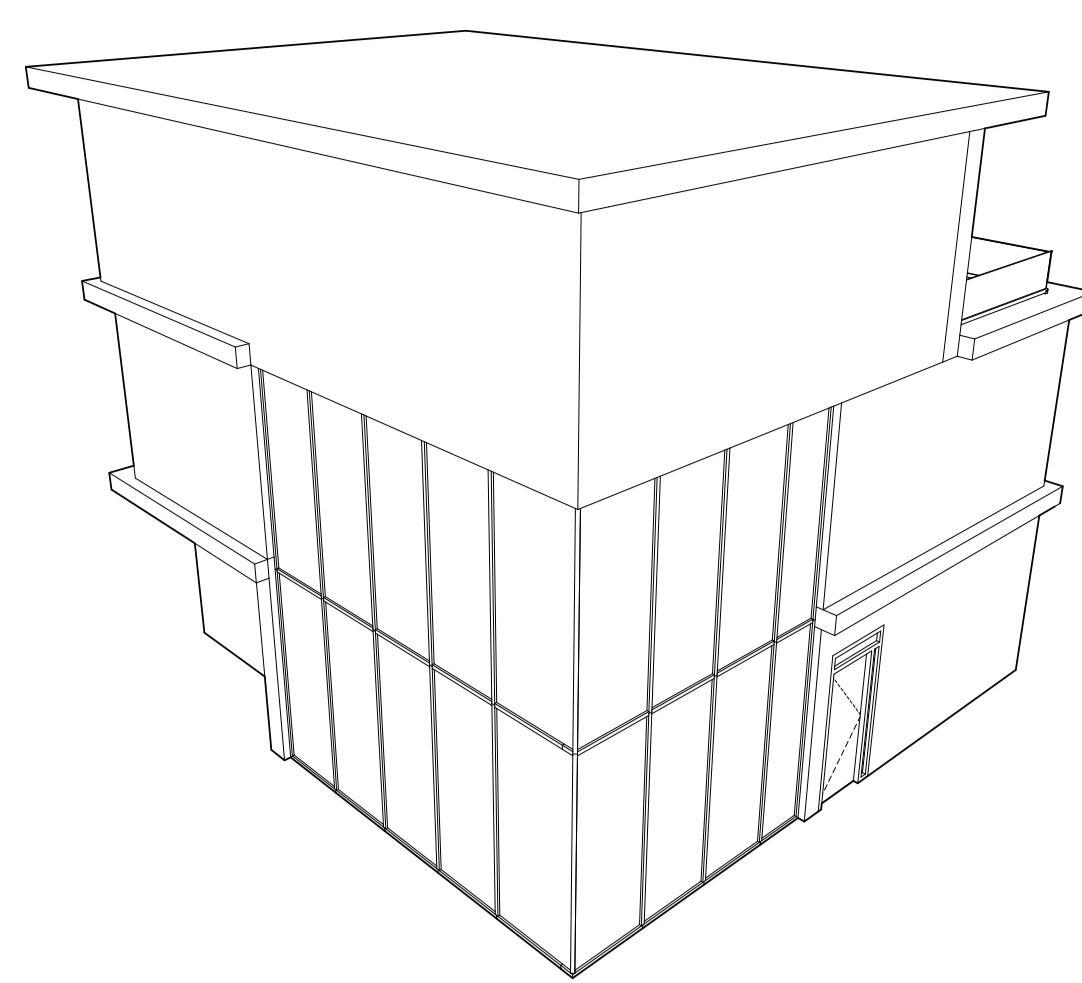

Vorm

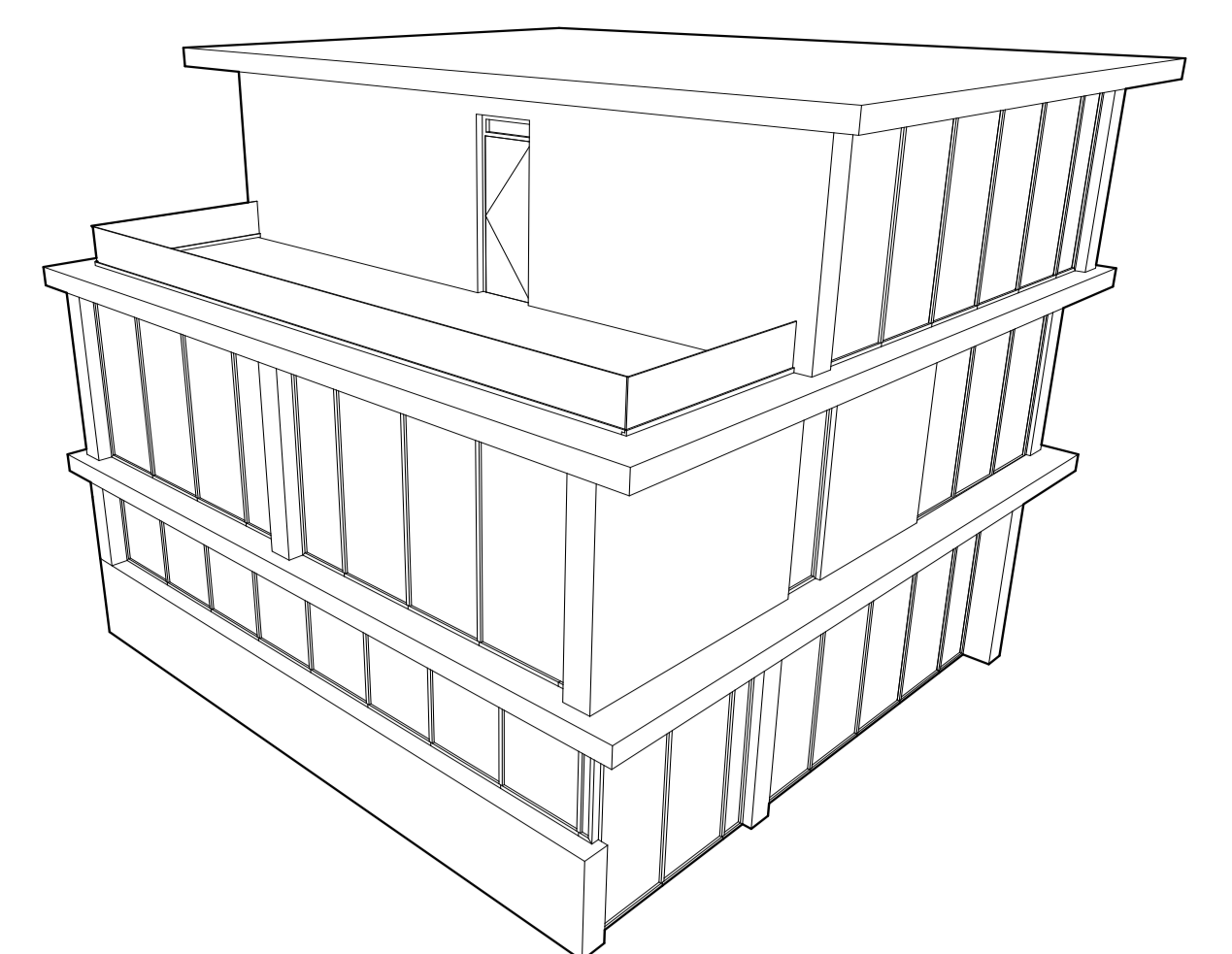

Vorm

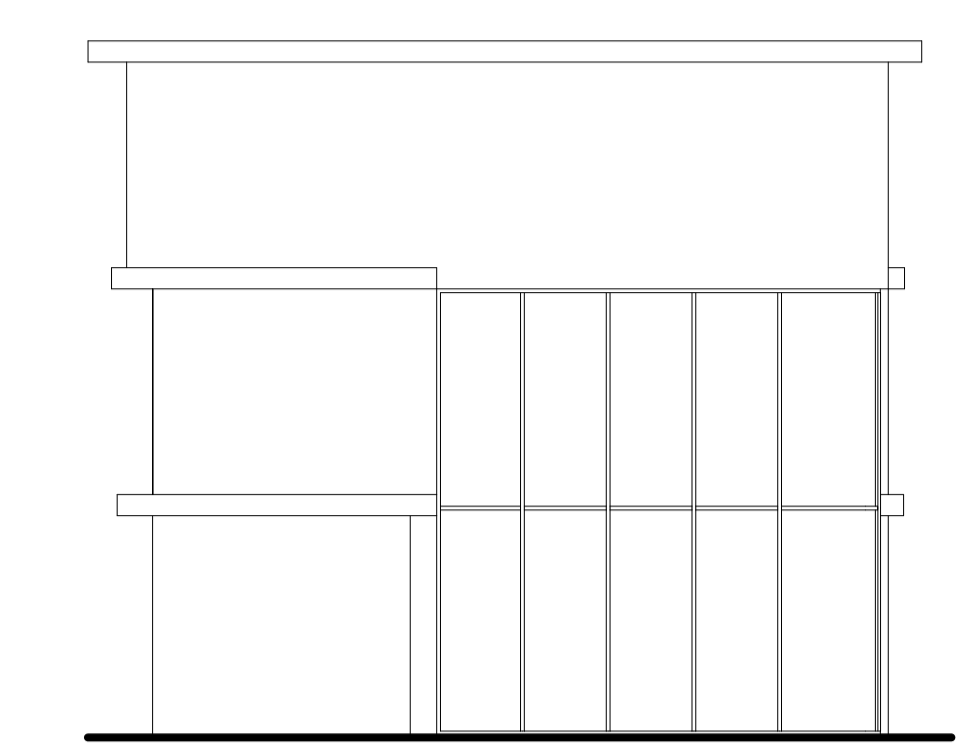

Linker zijgevel

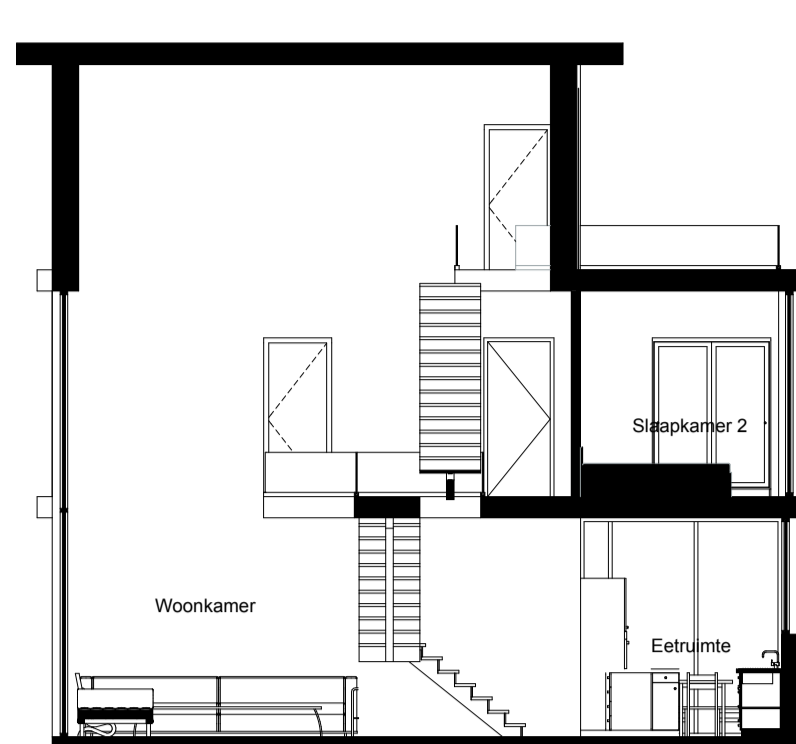

Doorsnede A-A

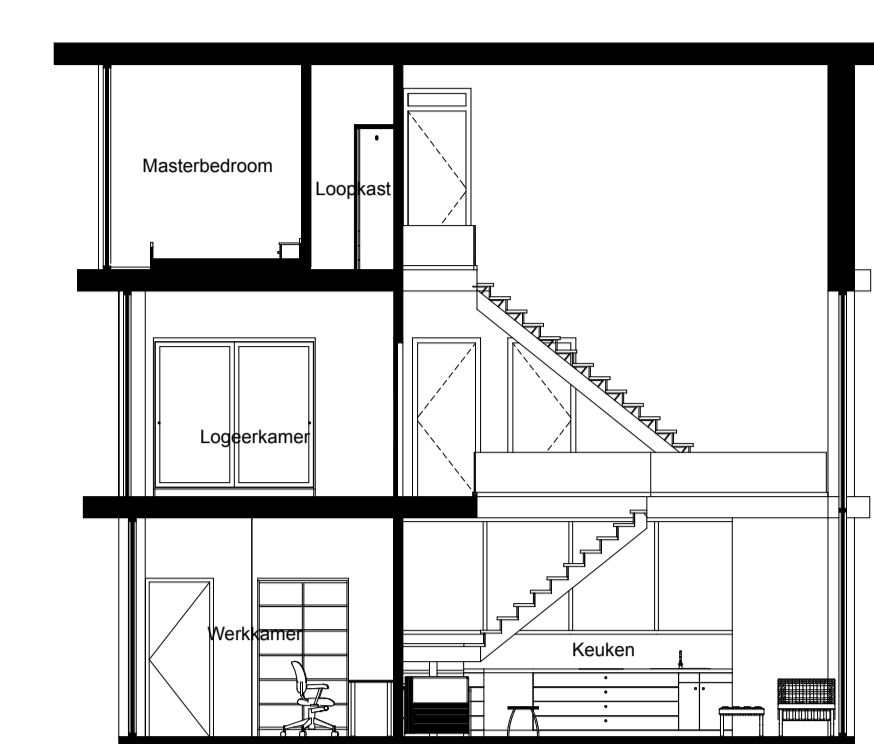

Doorsnede B-B

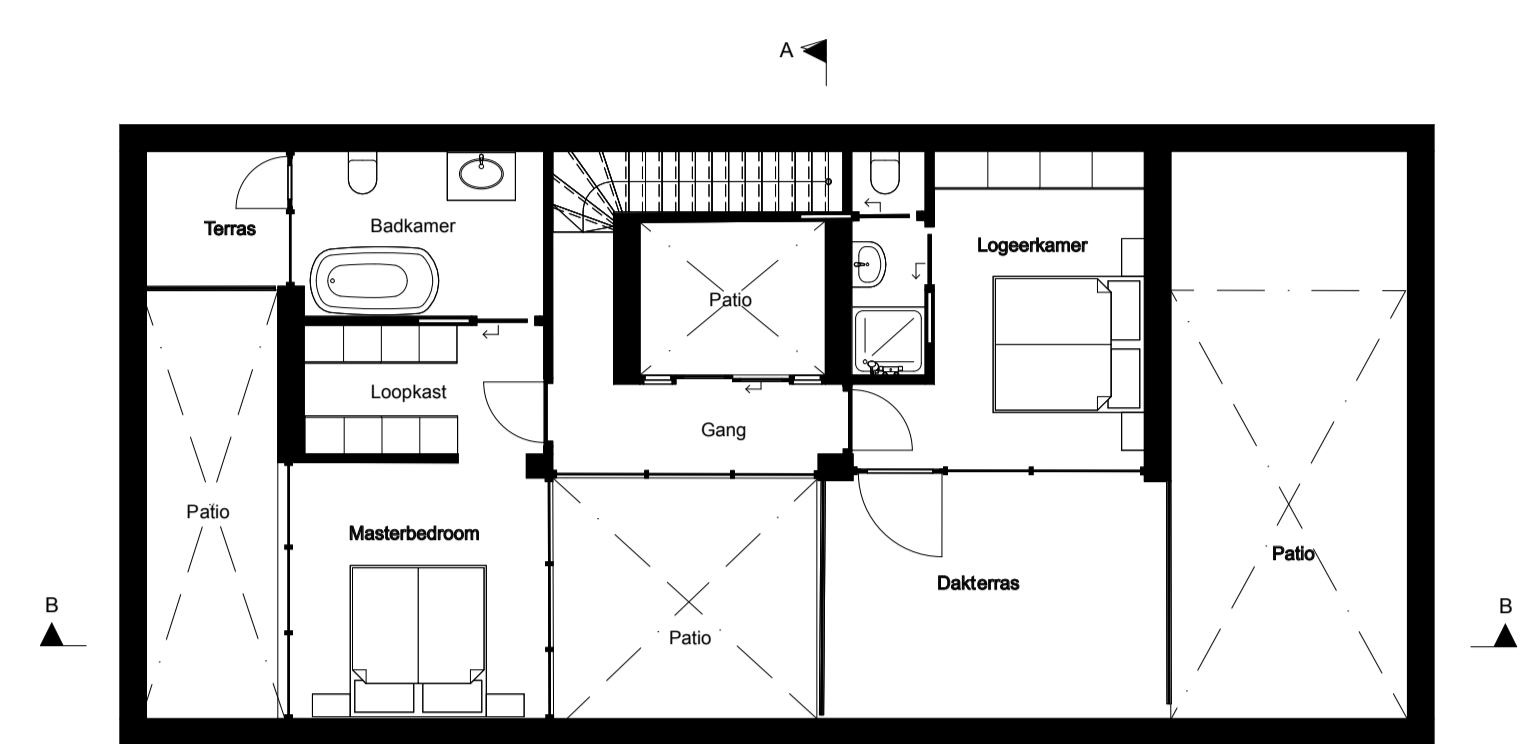

Dakaanzicht

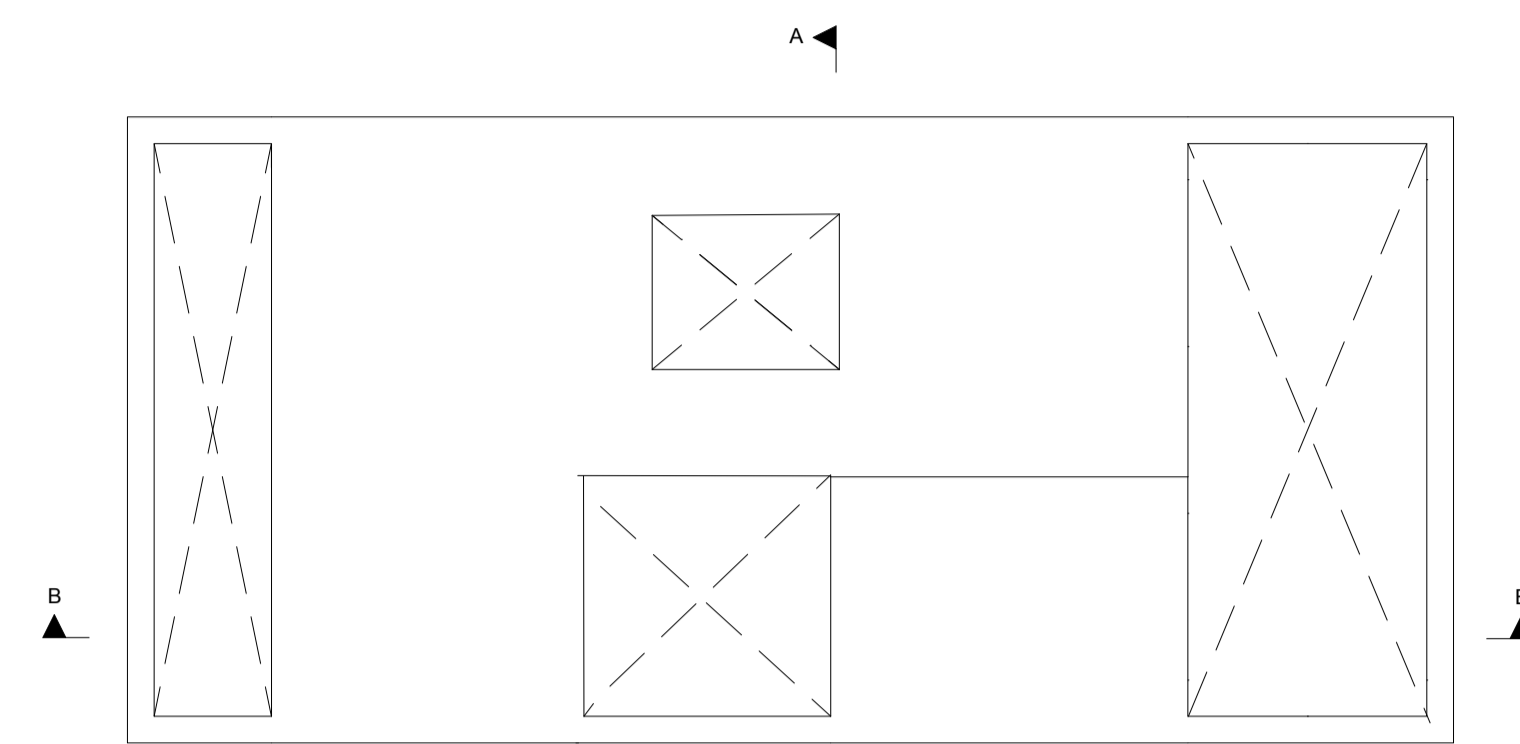

Dakaanzicht

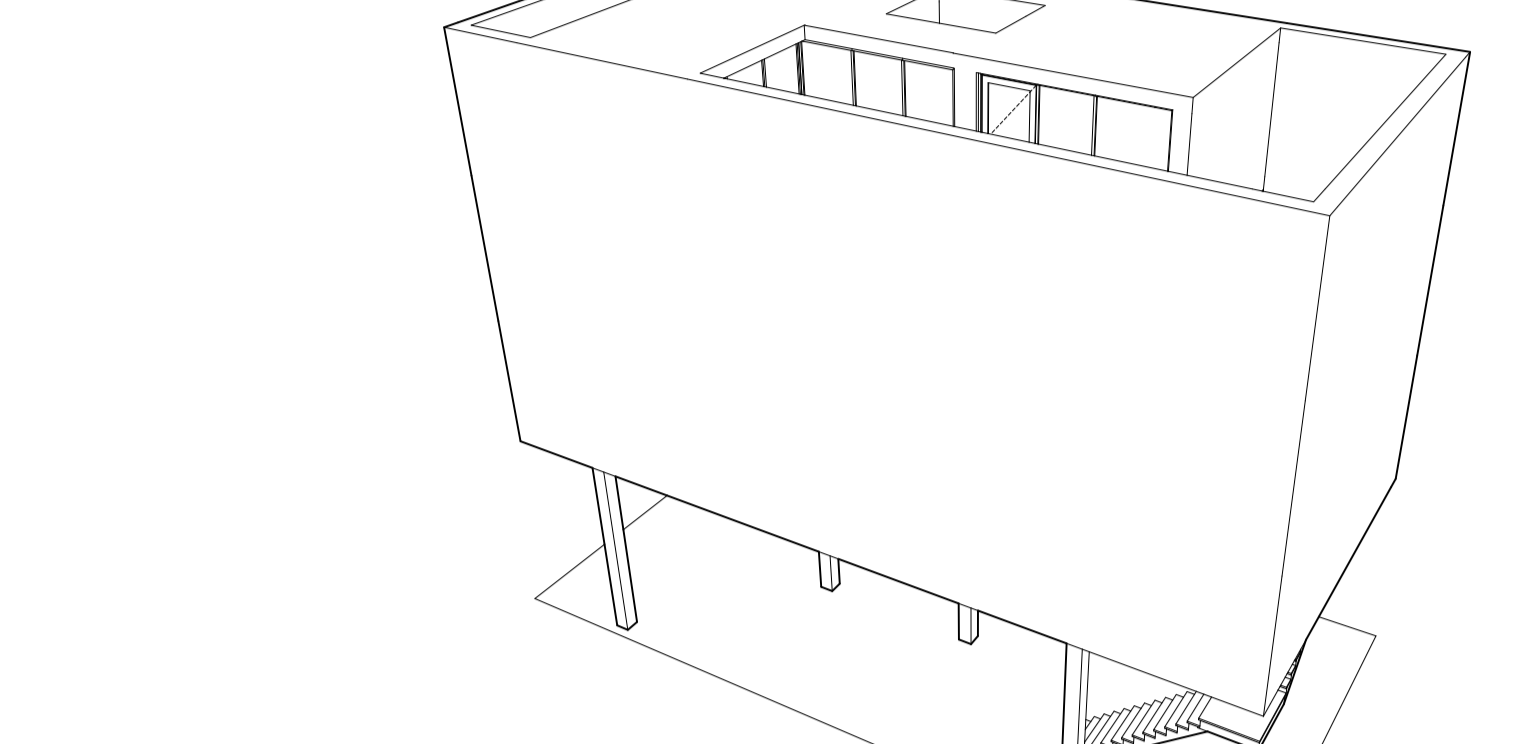

Vorm

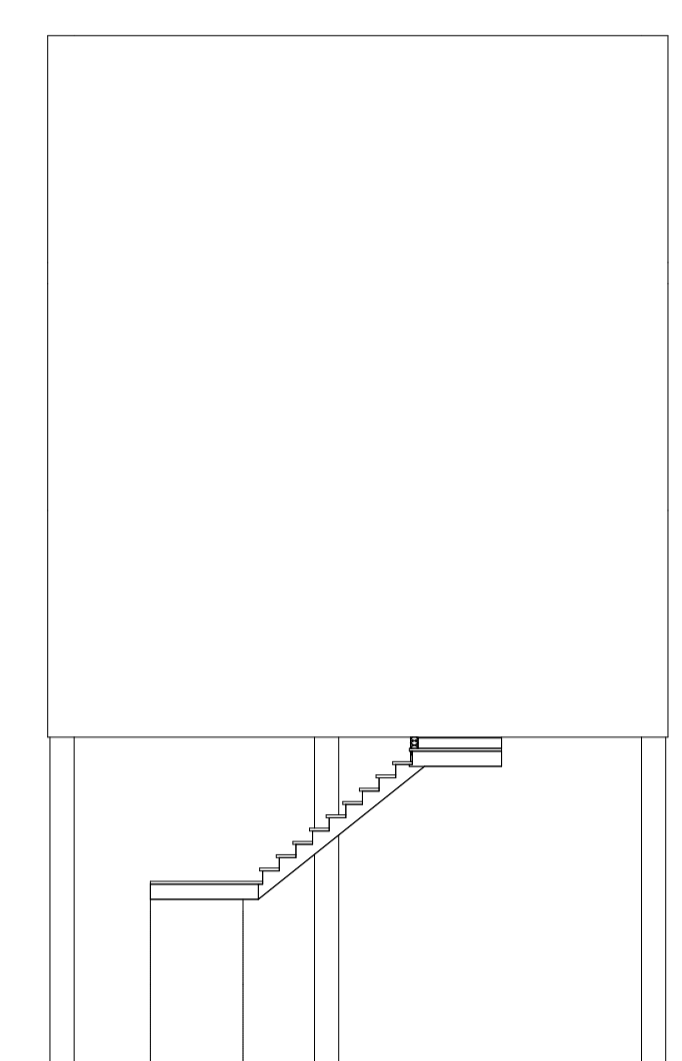

Linker zijgevel

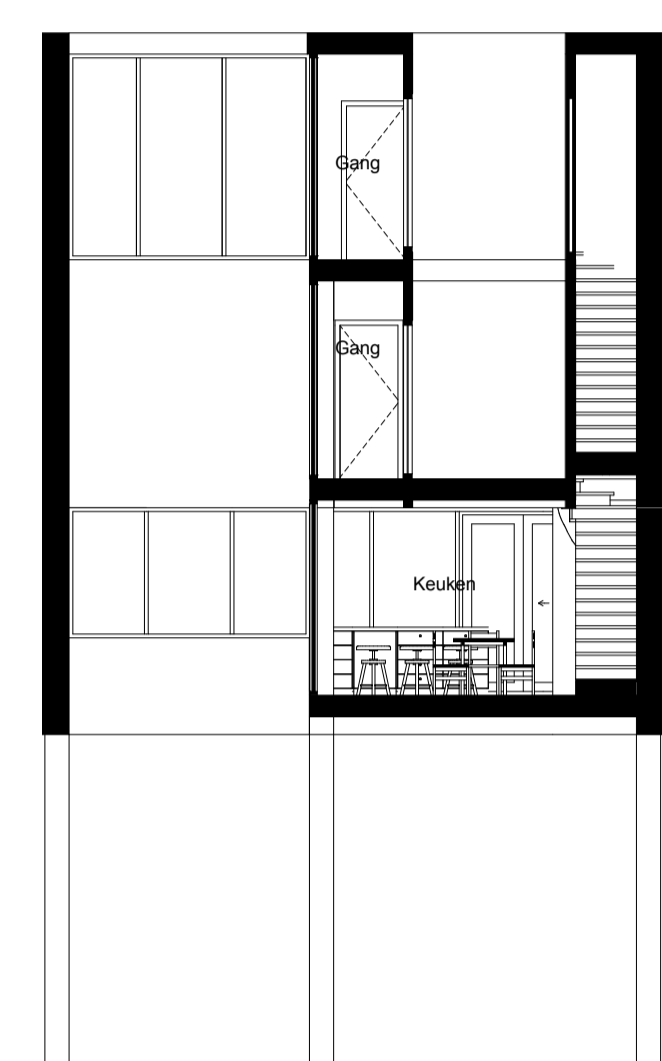

Doorsnede A-A

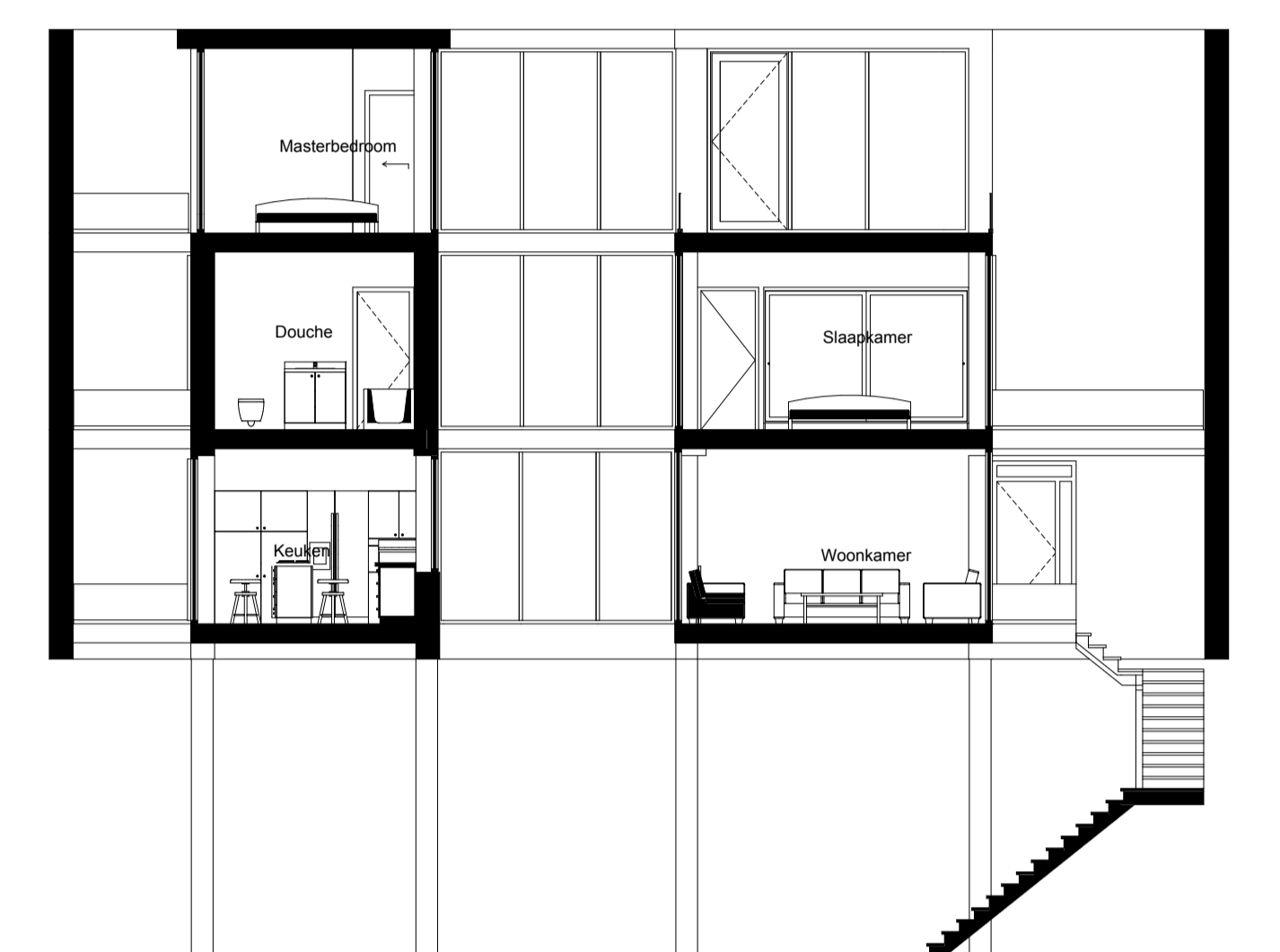

Doorsnede B-B

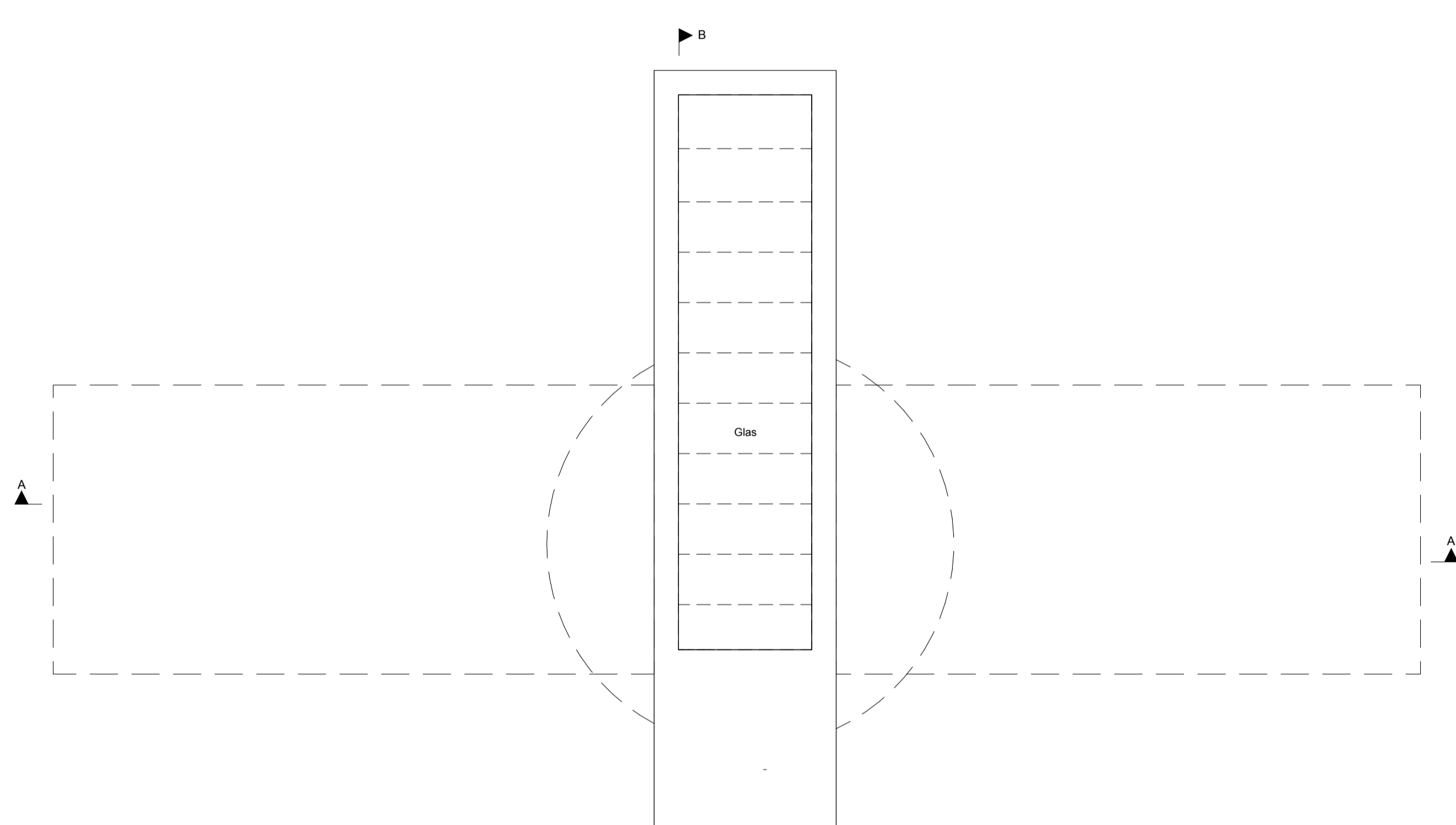

Dakaanzicht

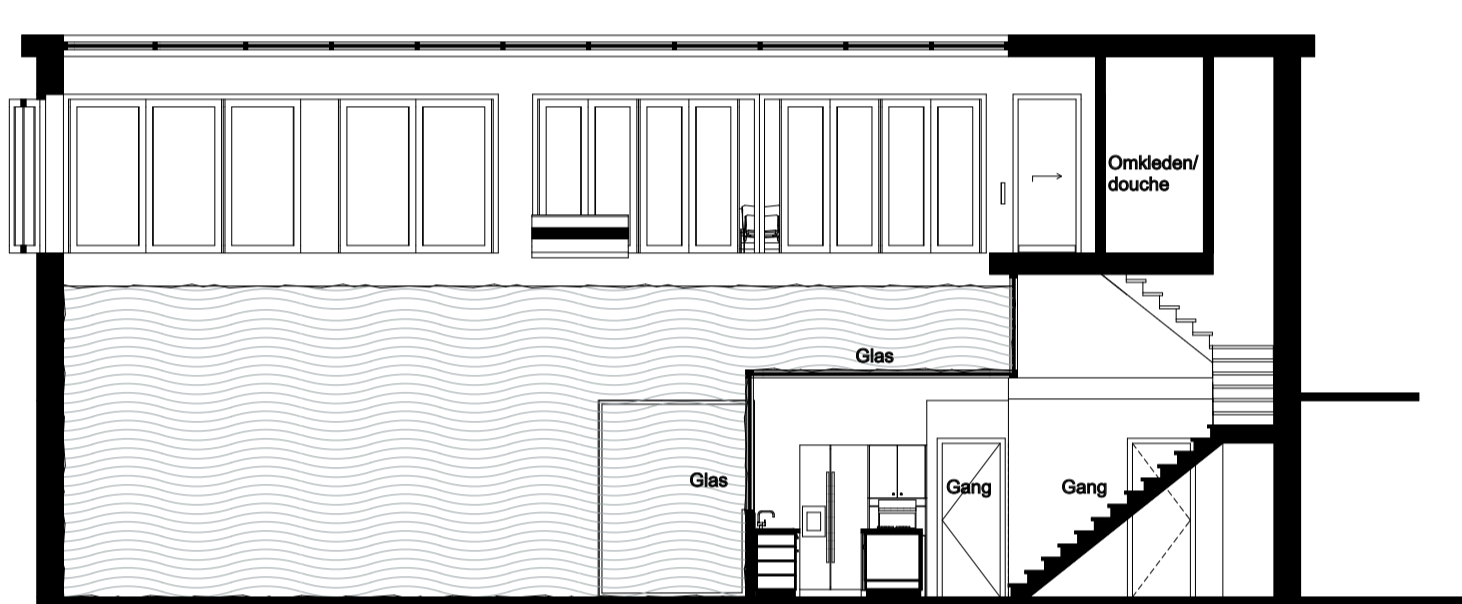

Doorsnede A-A

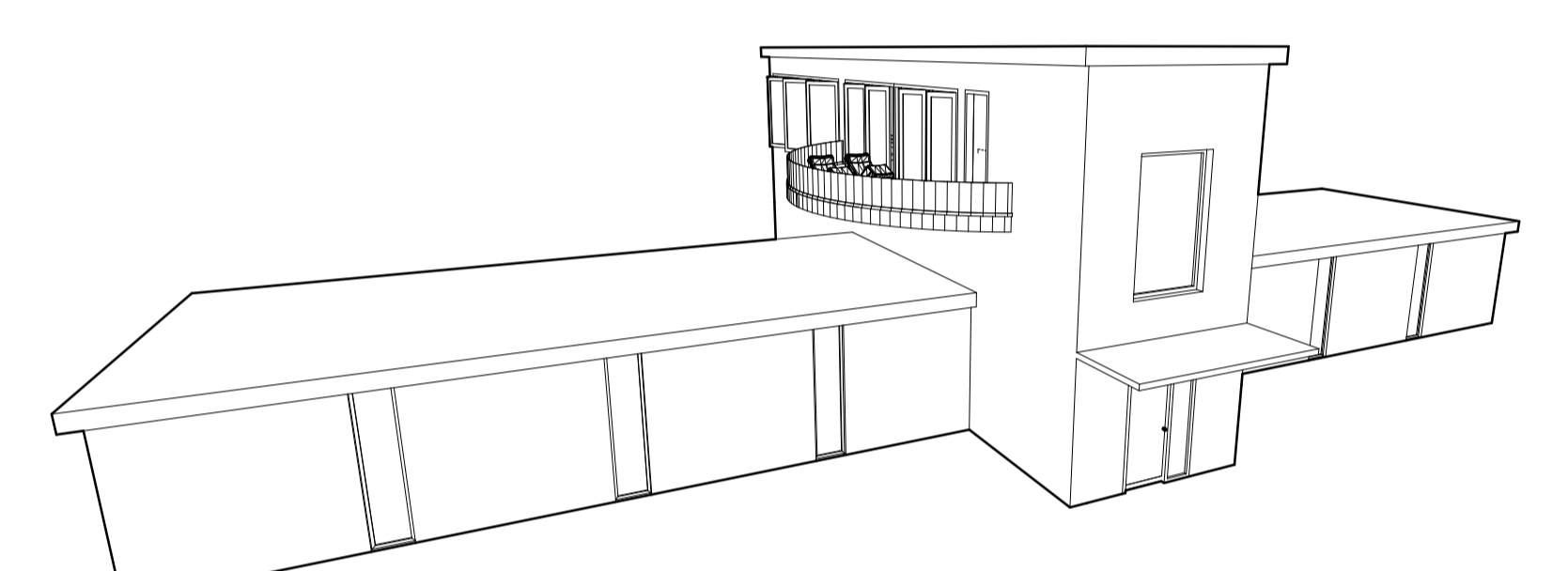

Vorm

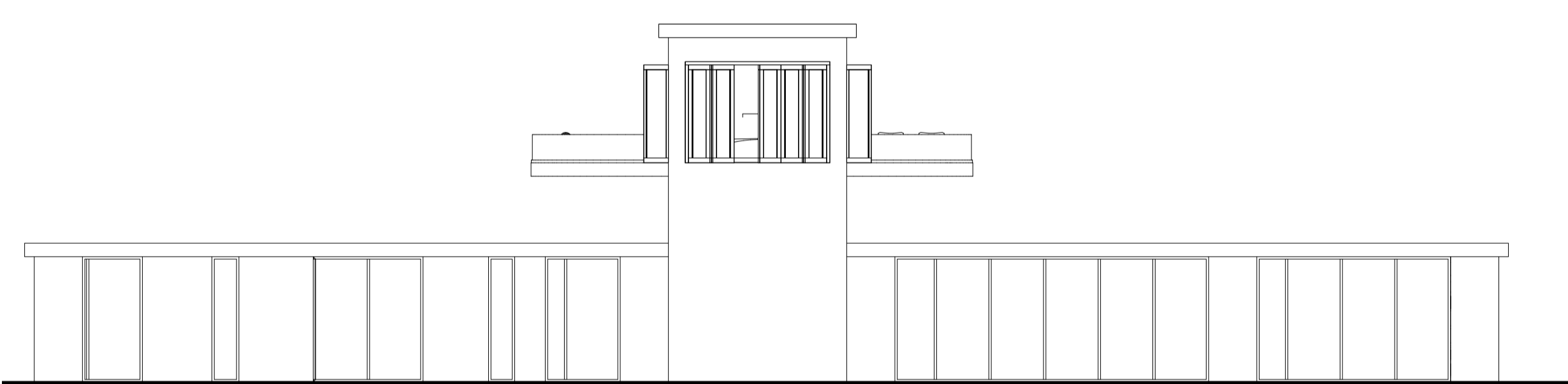

Achtergevel

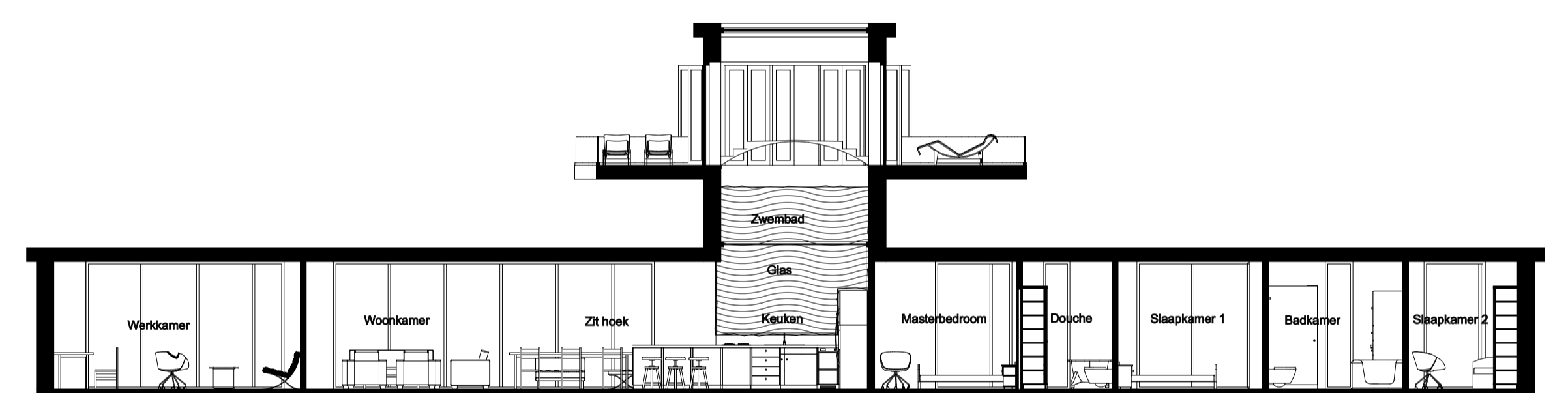

Doorsnede B-B

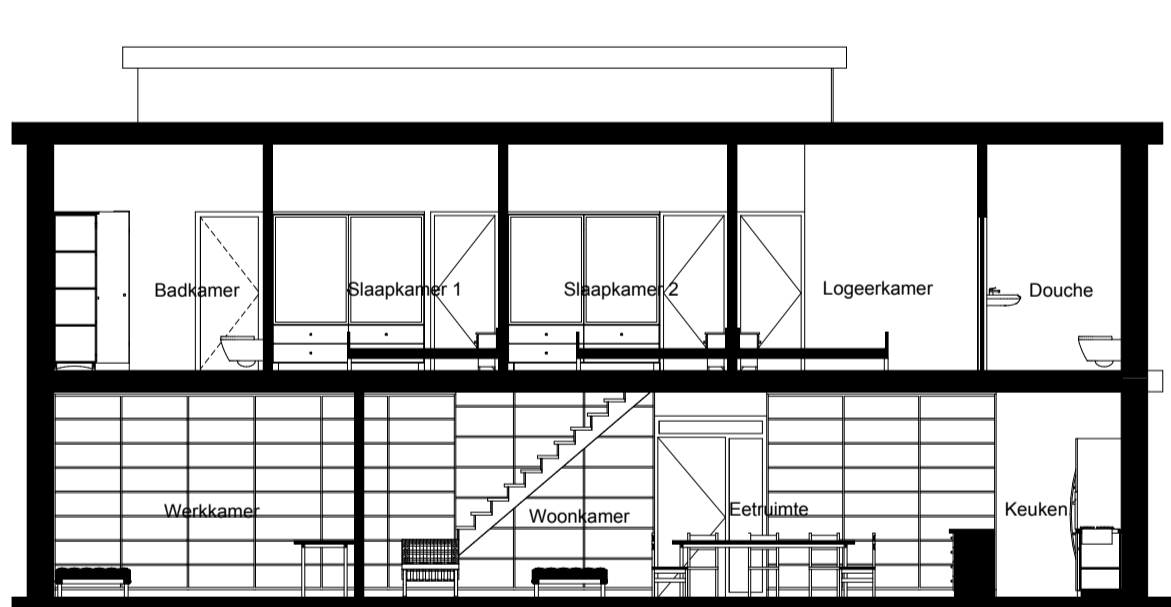

Doorsnede A-A

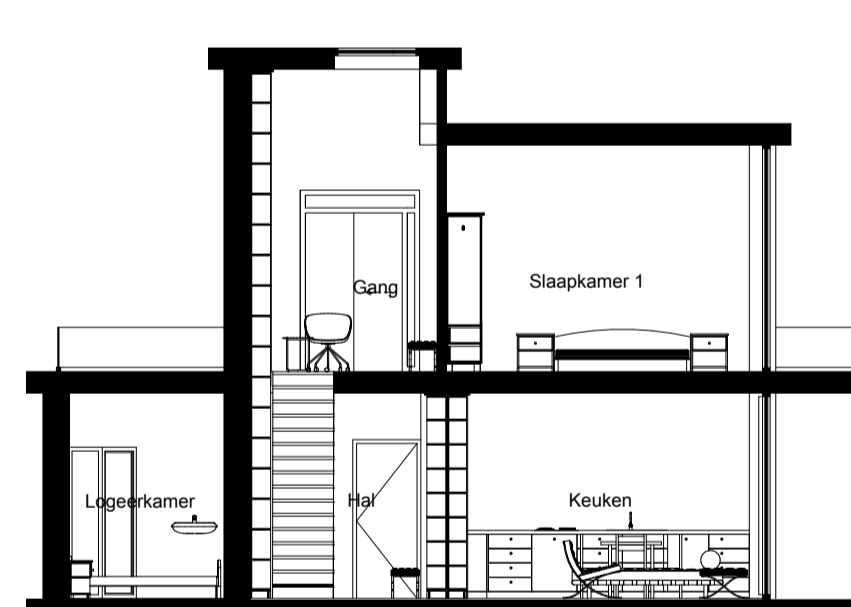

Doorsnede B-B

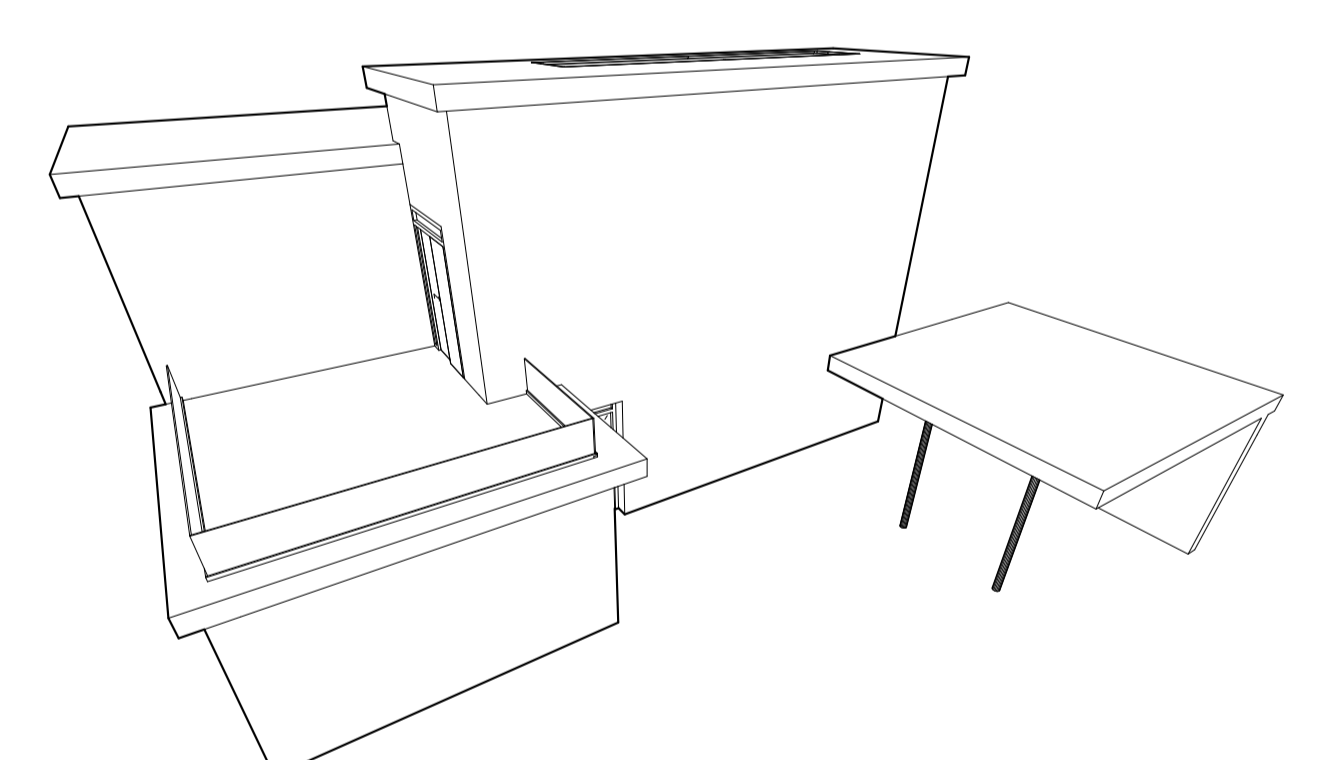

Vorm

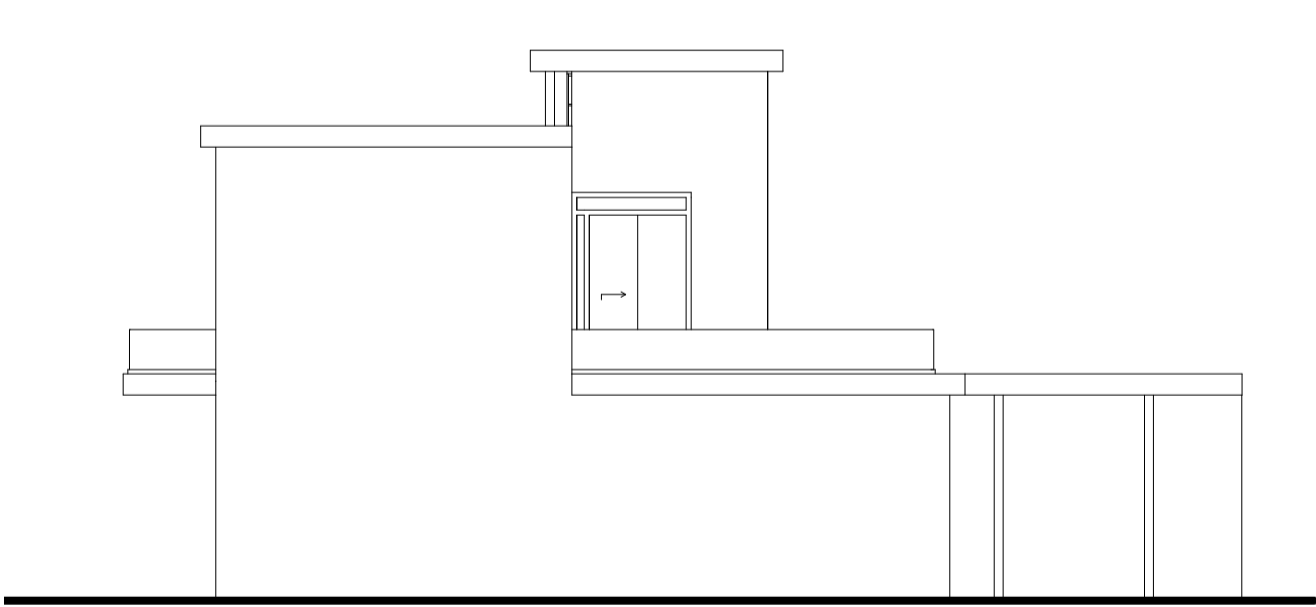

Linker zijgevel

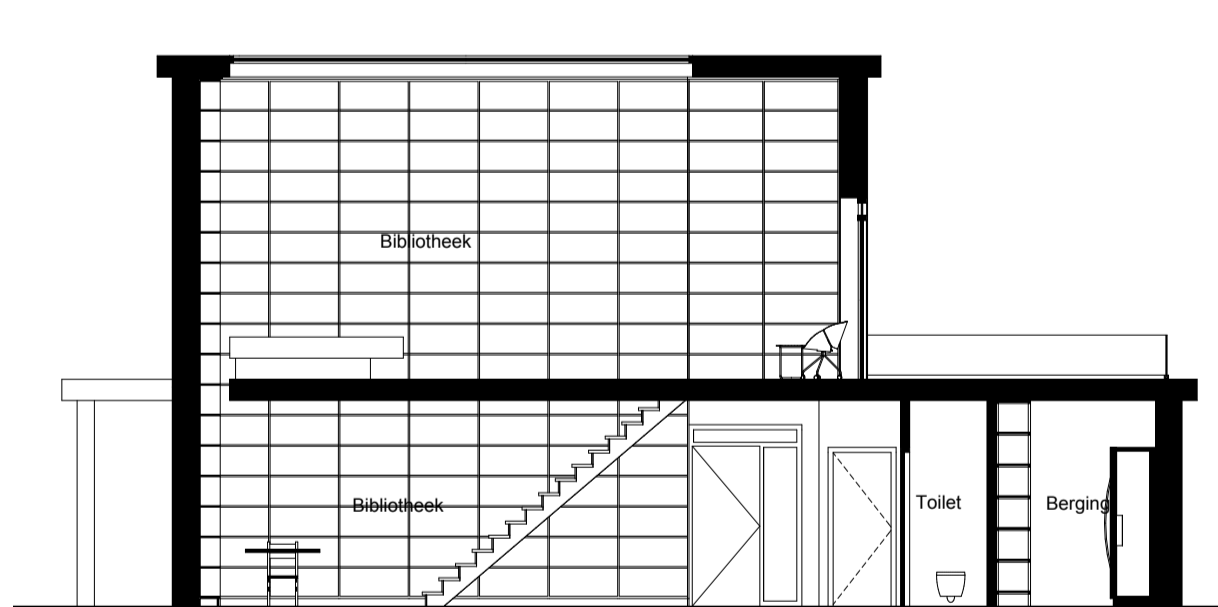

Doorsnede C-C

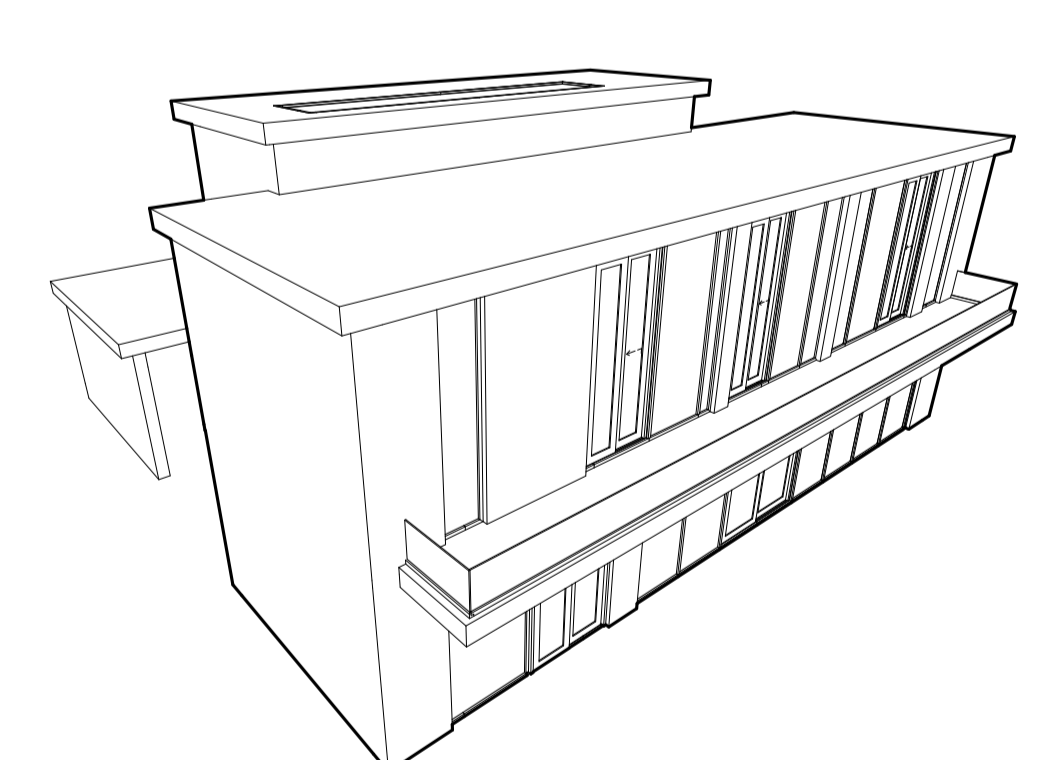

Vorm

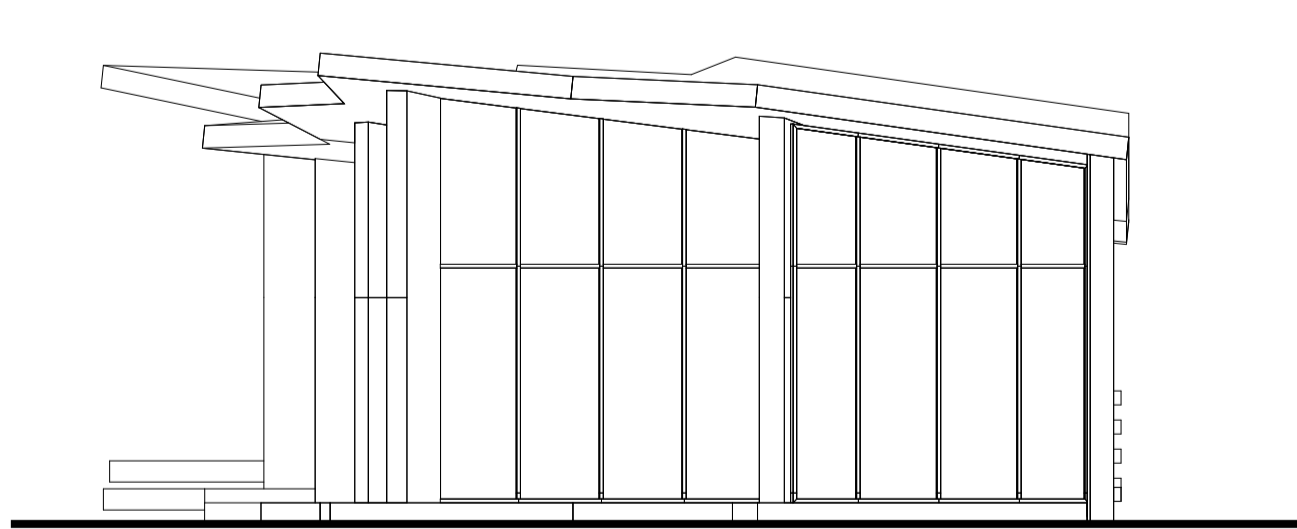

Linker zijgevel

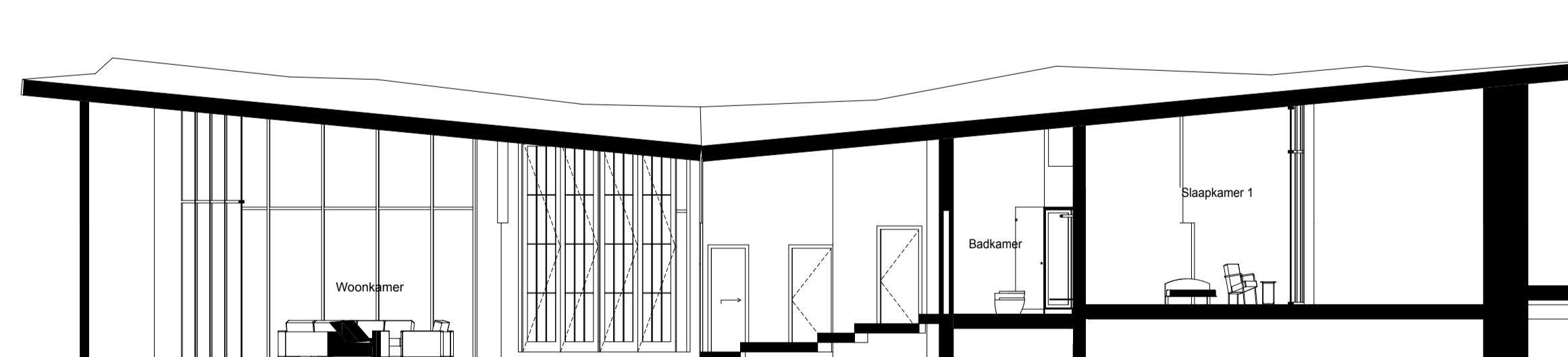

Doorsnede A-A

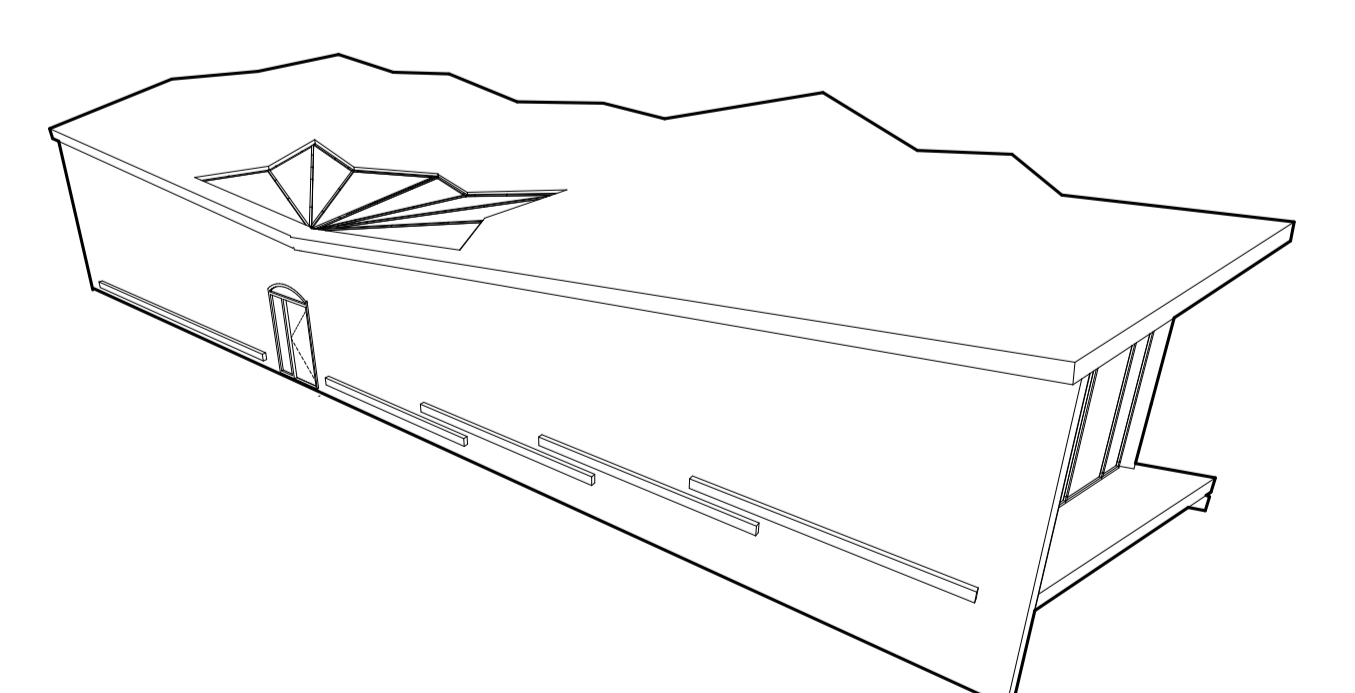

Vorm

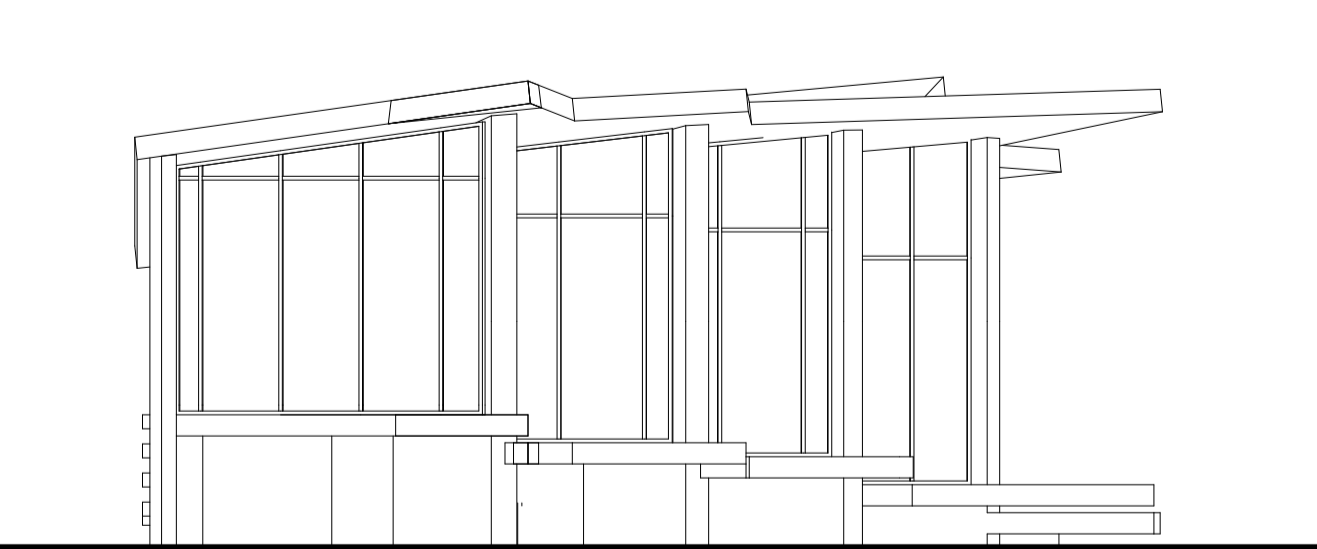

Rechter zijgevel

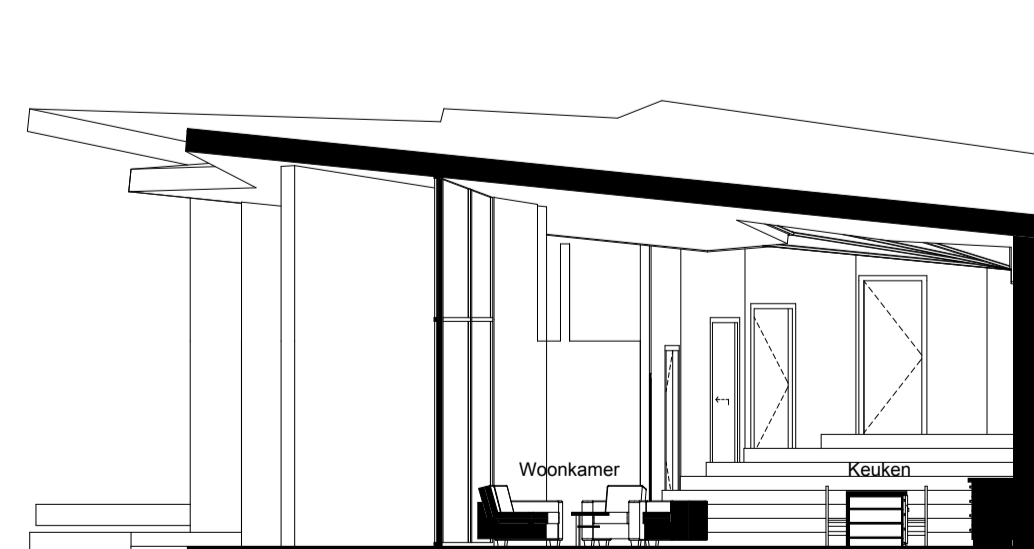

Doorsnede B-B

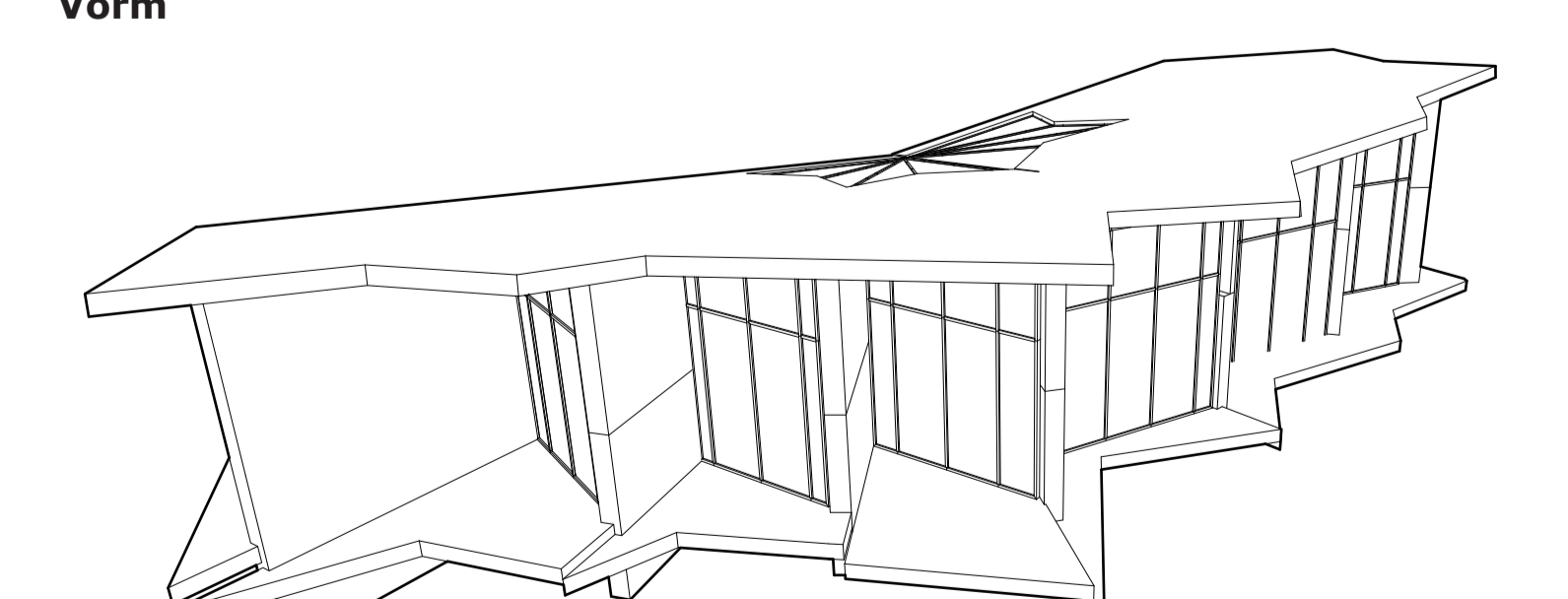

Vorm

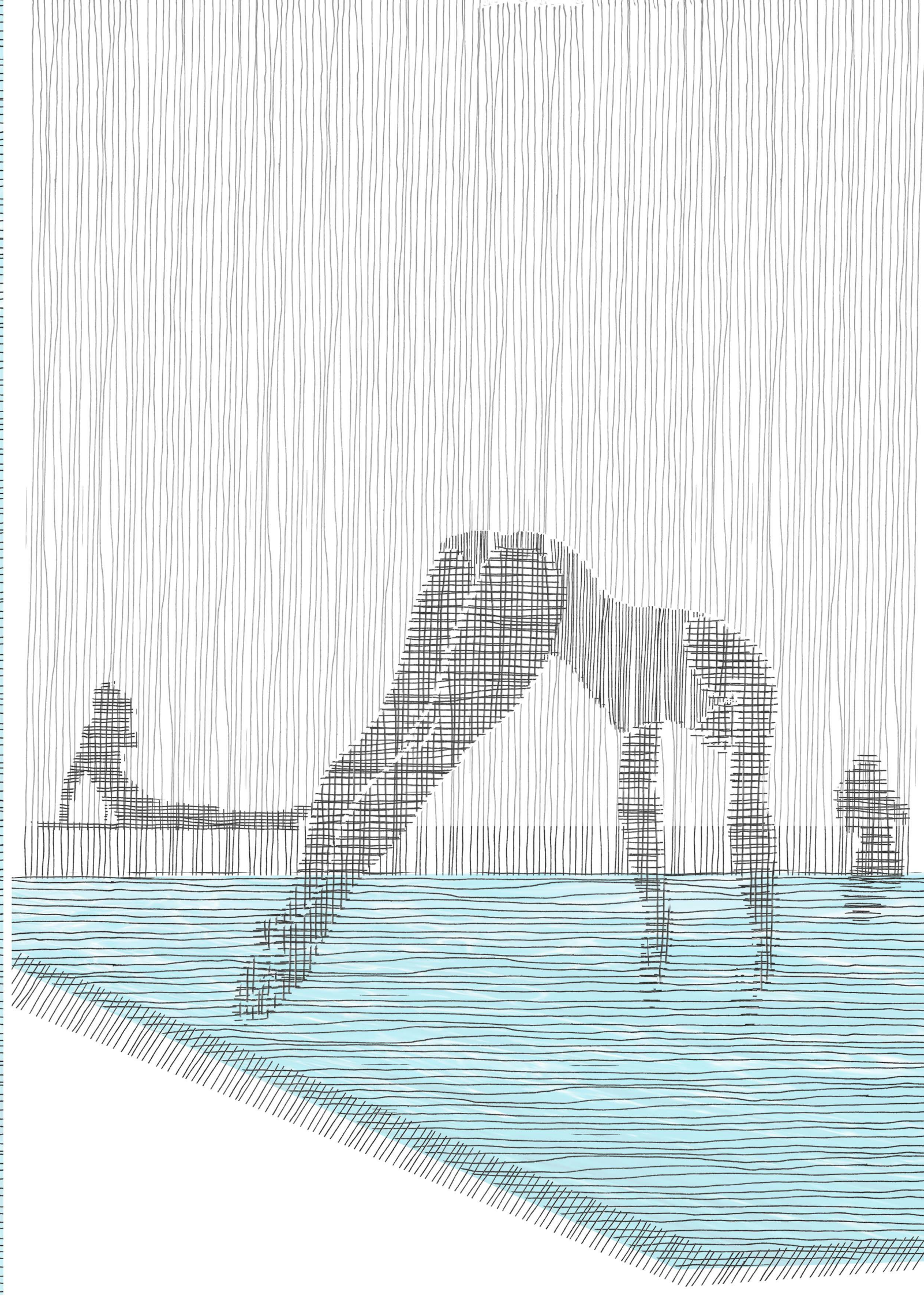

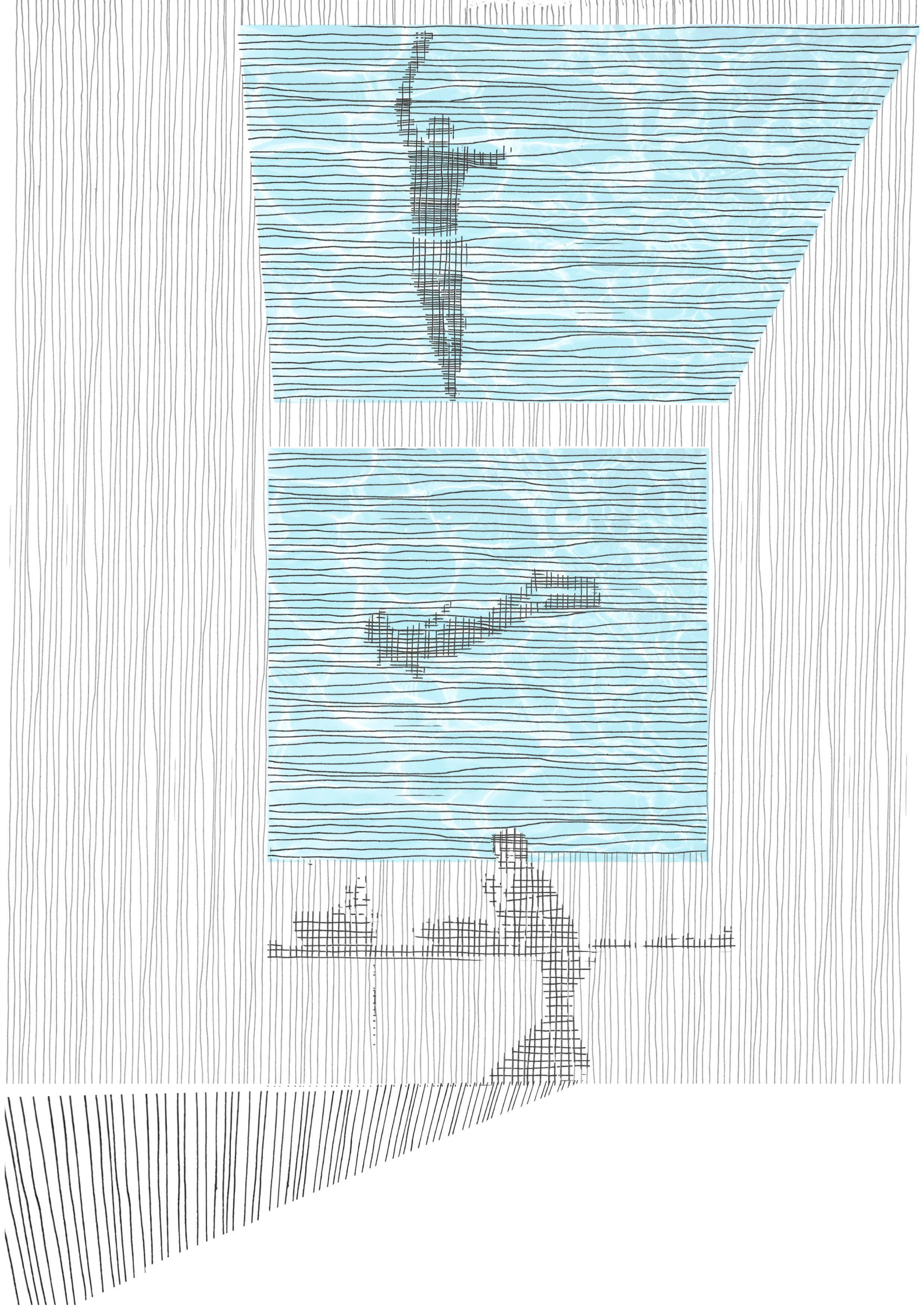
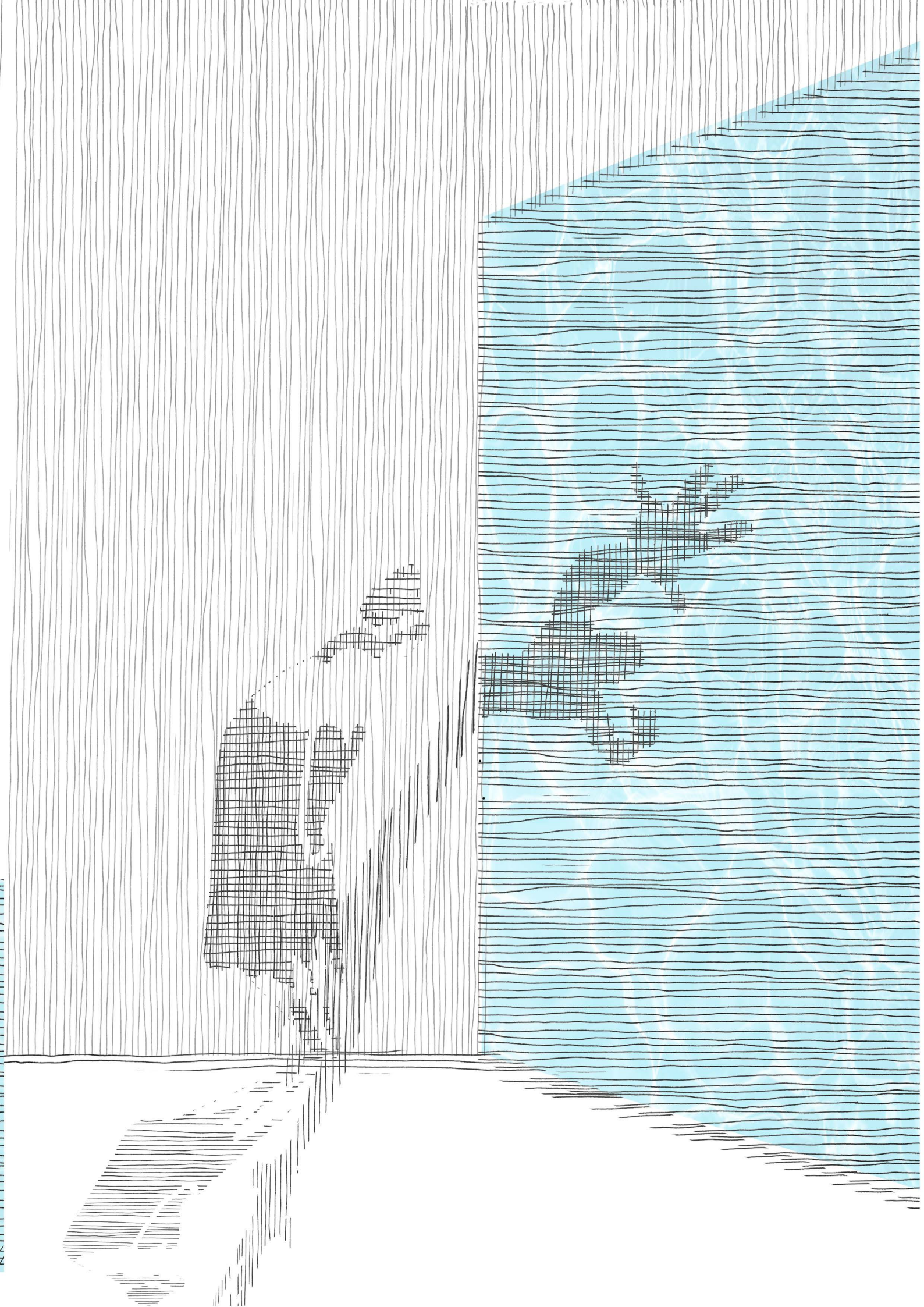

Studio:

Elementair Ontwerpen

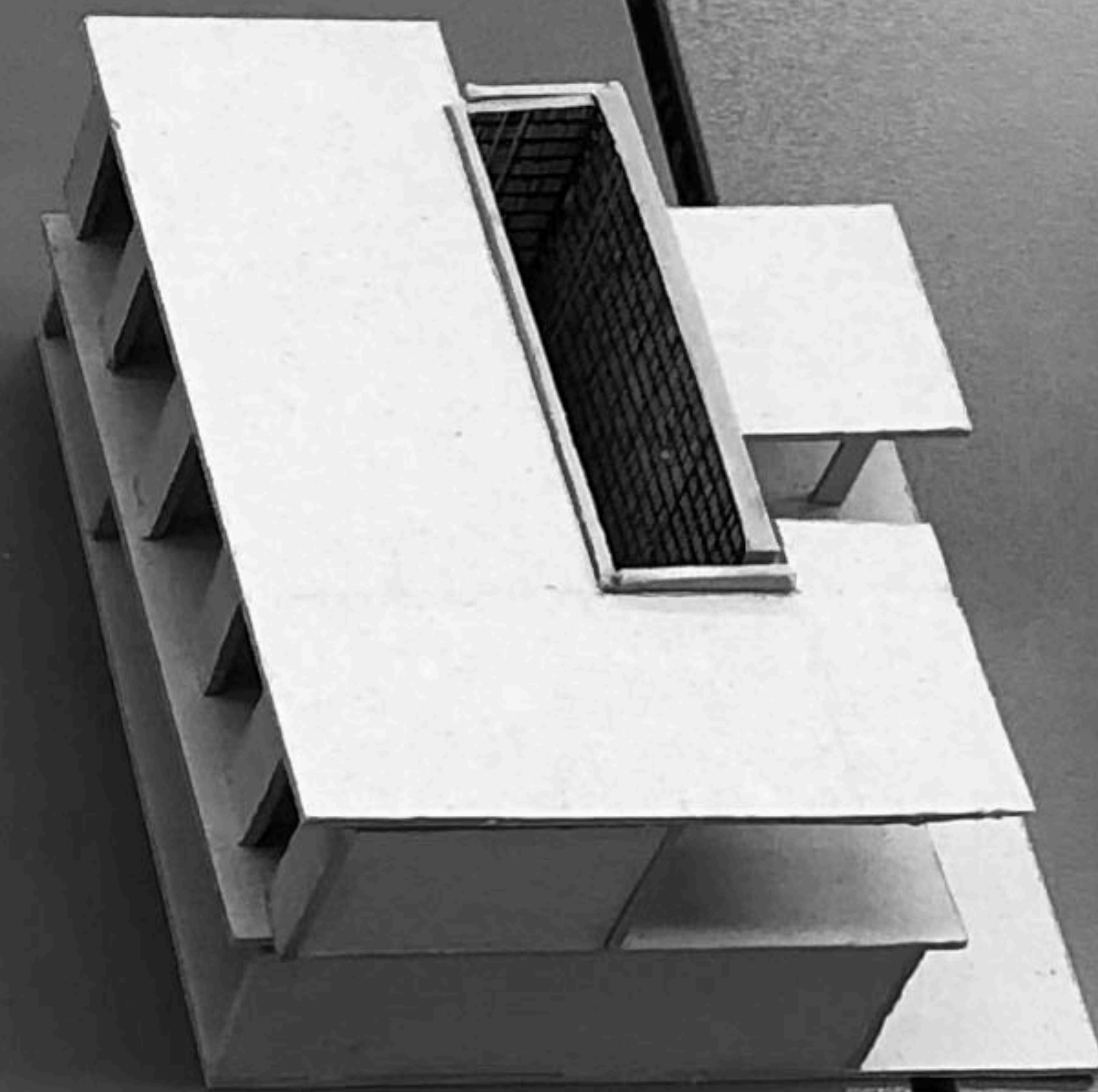
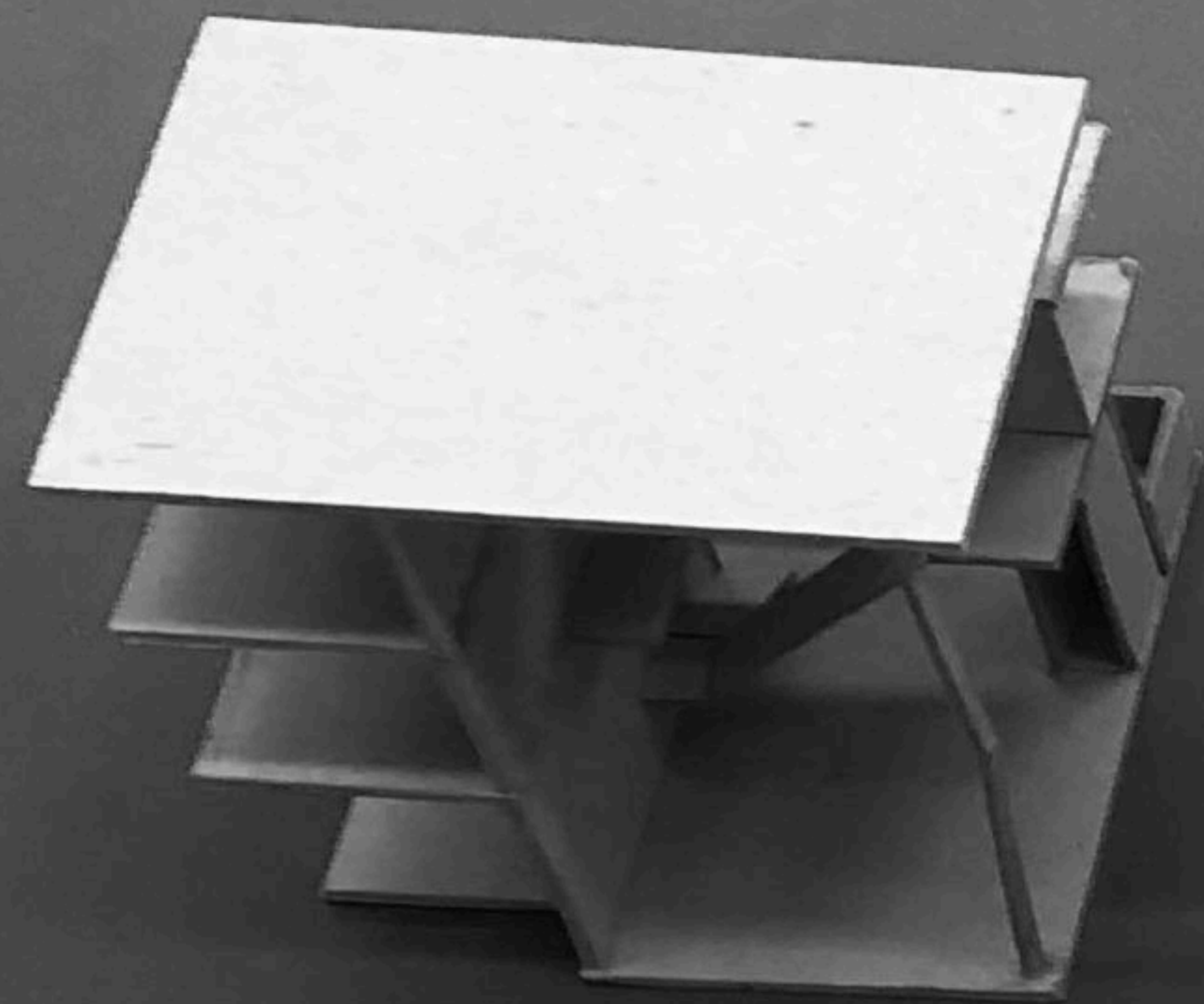

Elementair ontwerpen

Is een studio waar het draait om het oefenen in ontwerpen. Doormiddel van zes korte oefeningen gebaseerd op de didactiek van de Duitse architect O.M. Ungers wordt het architectonisch denken getriggerd. De zes opgave draaien om het ontwerpen van een geweldig huis. Ieder huis heeft het zelfde programma van eisen, maar daarbij heeft ieder huis een andere op het eerste gezicht merkwaardige randvoorwaarde:

1. Een huis die elke zijde van een kubus van 10x10x10 meter raakt.
2. Een huis zonder ramen aan de buitenzijde en de entree op 4,75 meter hoog.
3. Een huis met een zwembad van 12x3,5 meter.
4. Een huis met 250 strekkende meter boeken.
5. Een huis zonder gangen.
6. Een scenario geheel naar eigen invulling.

HUIS I 10x10x10

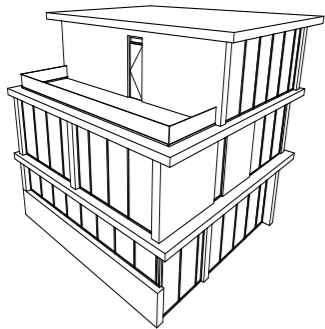
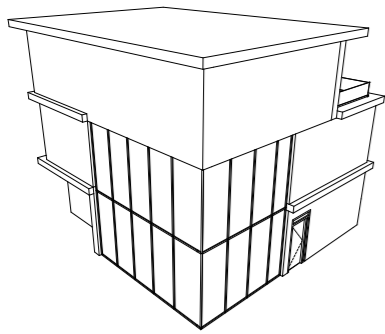

HUIS II zonder ramen

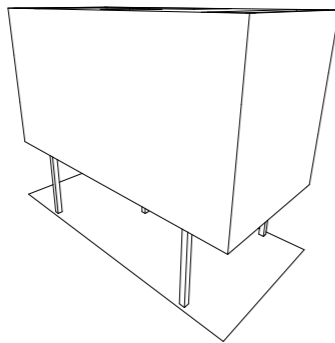
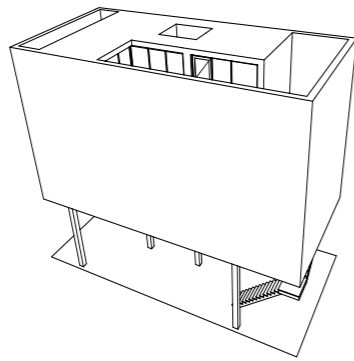

HUIS III Zwembad

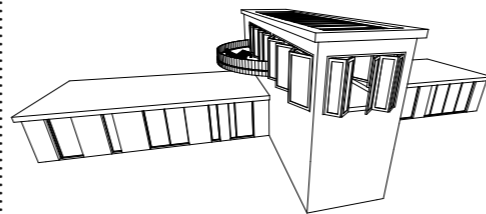
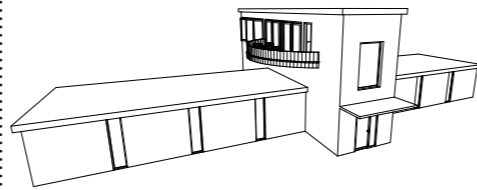

HUIS IV Boekenkast

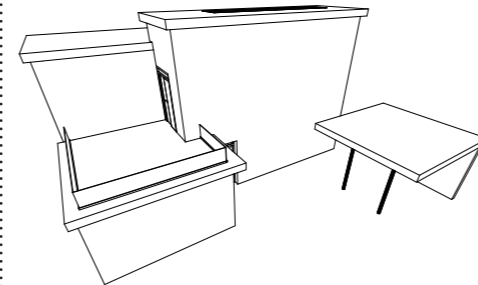
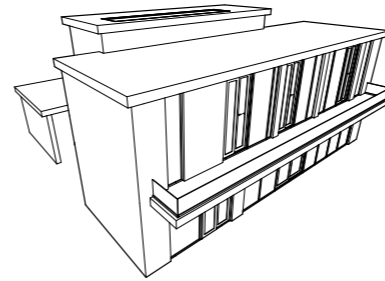

HUIS V Zonder gang

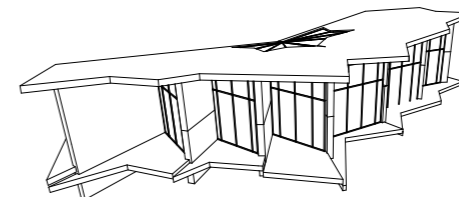
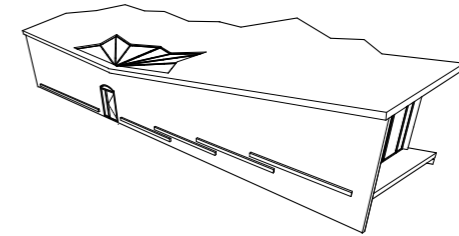

HUIS VI StoryBoard.

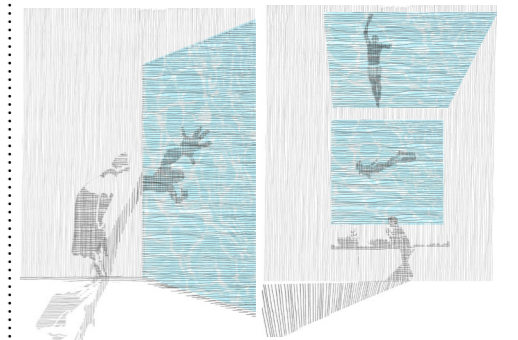
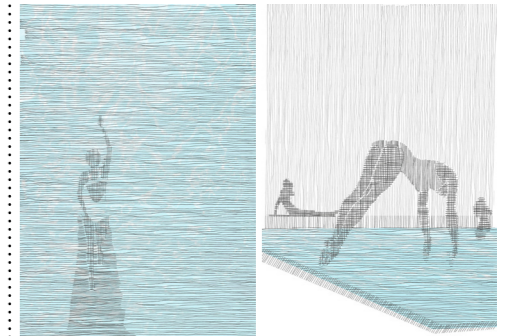

HUIS I

Het huis past in een kubus van 10 m x 10 m x 10 m en raakt tenminste éénmaal aan alle vlakken van die kubus.

Concept: Binnen is buiten

Uitgangspunten:

- 1- Omgeving - Water/groen →
- 2- Zichtlijnen naar buiten →
- 3- Zichtlijnen naar binnen →

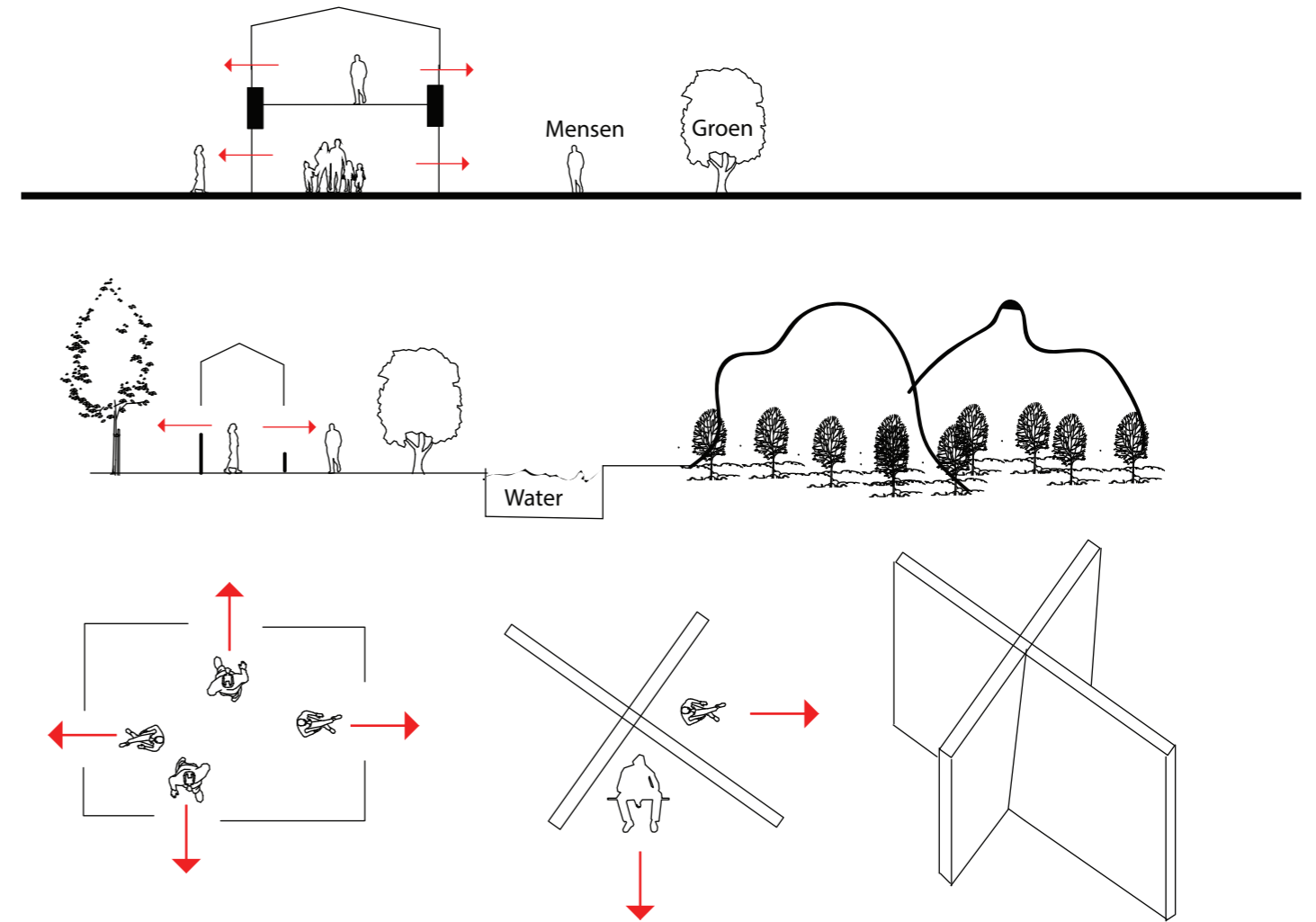

Beganegrond

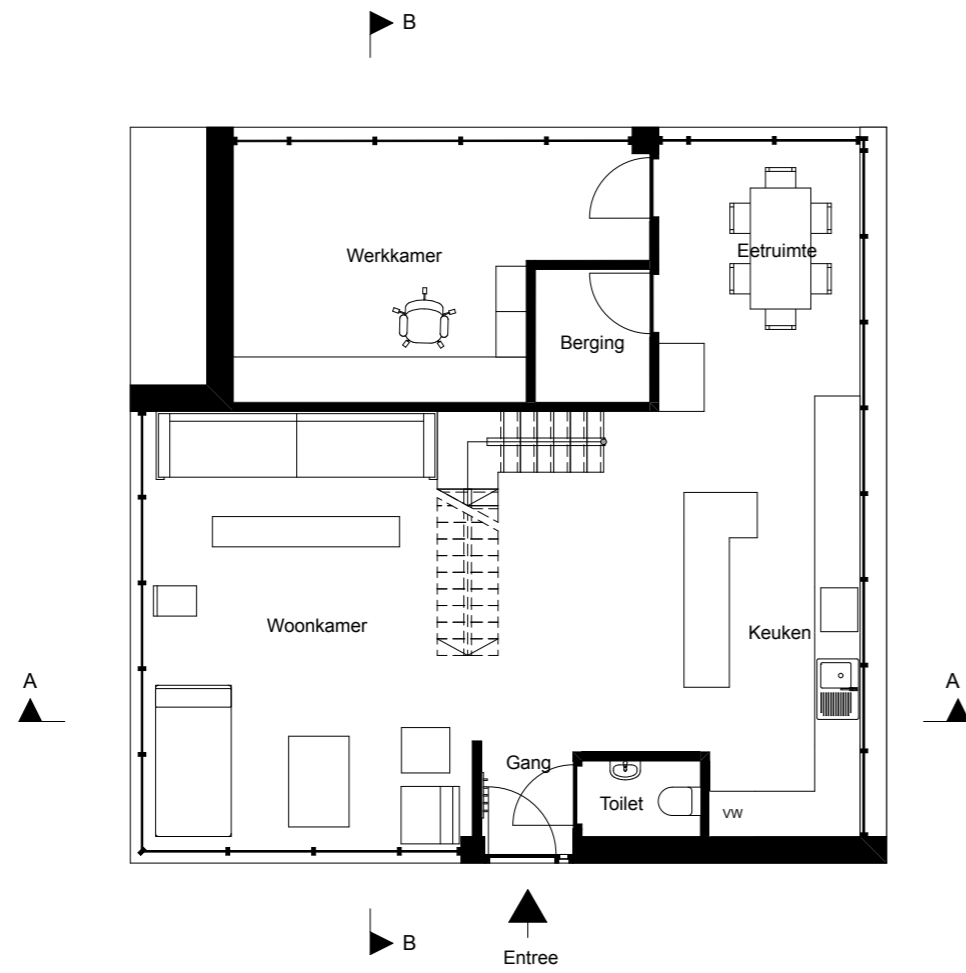

1e Verdieping

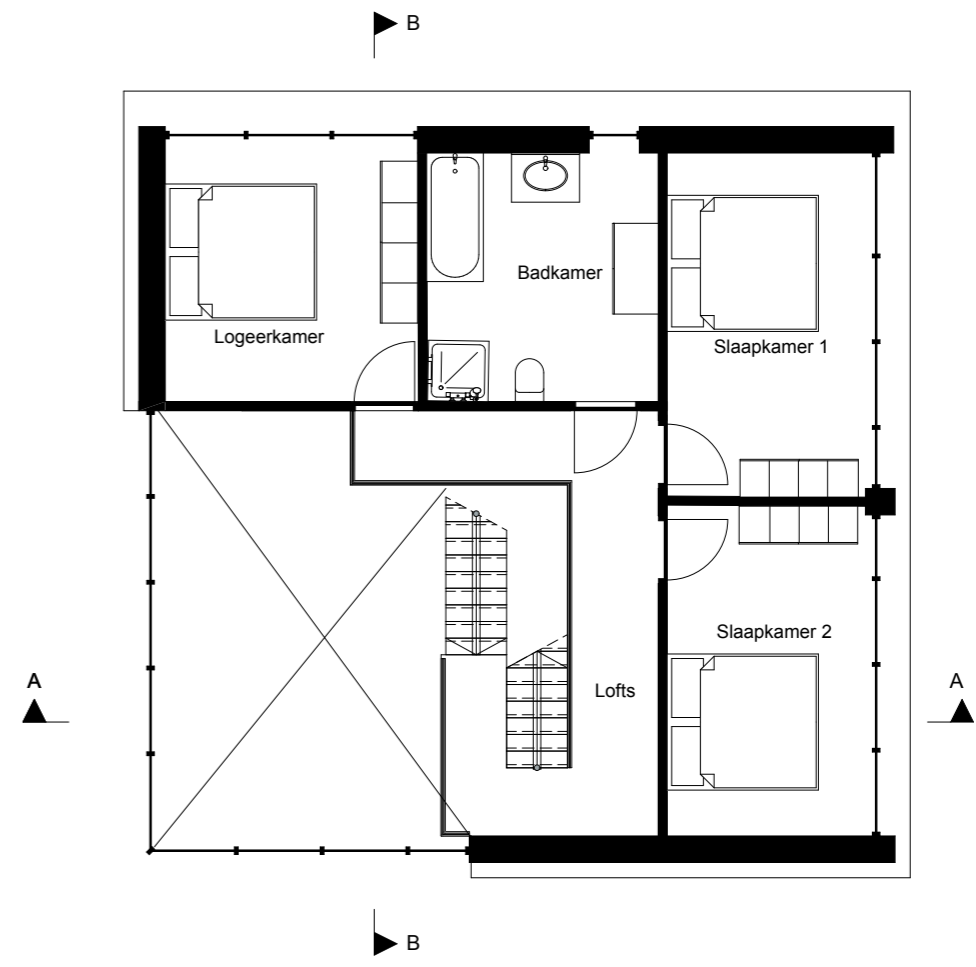

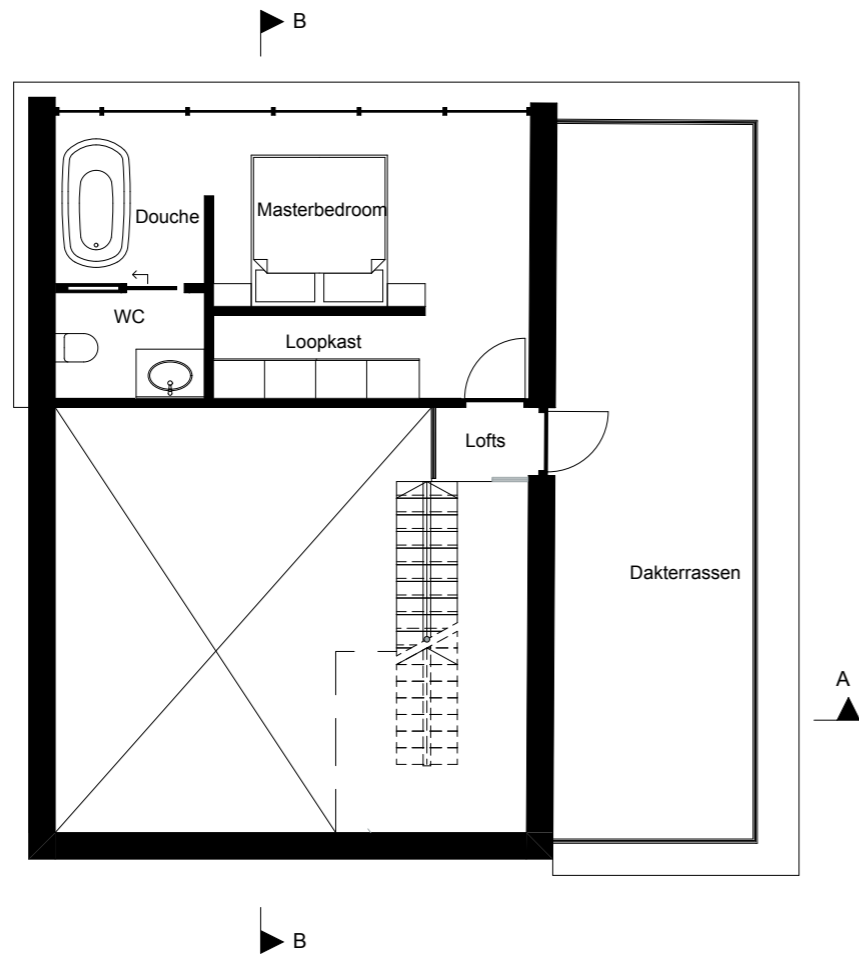

2e Verdieping

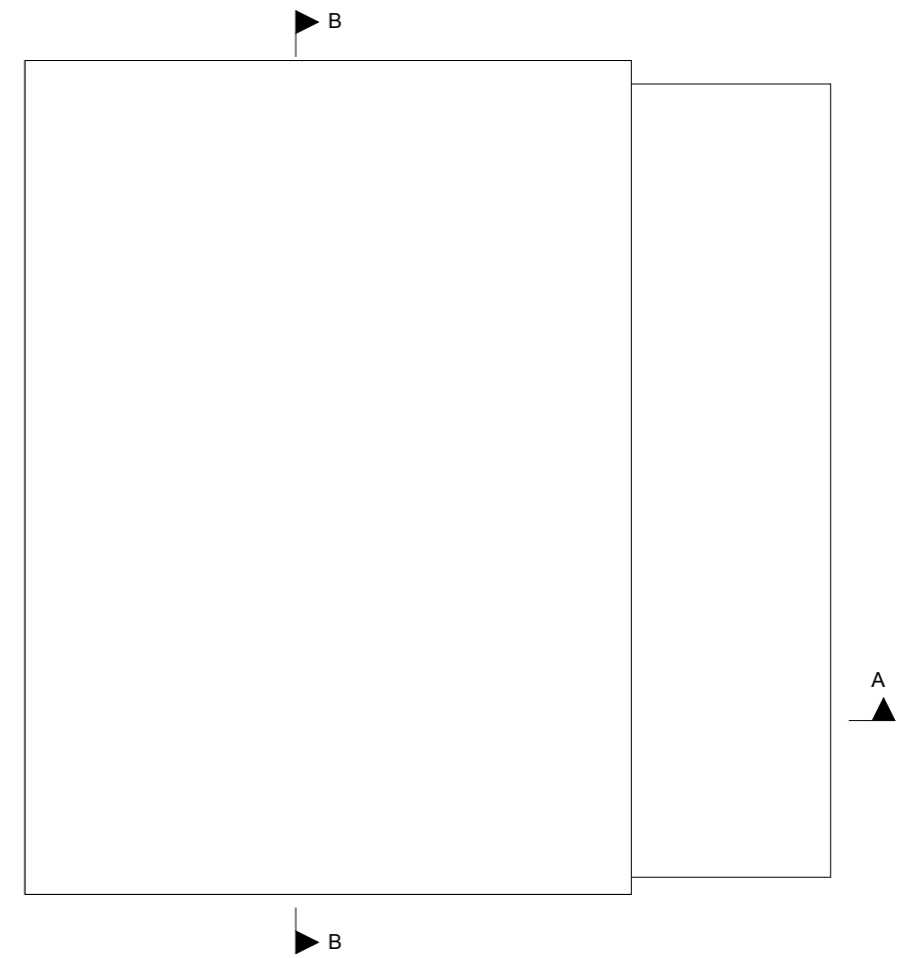

Doorsnede B-B

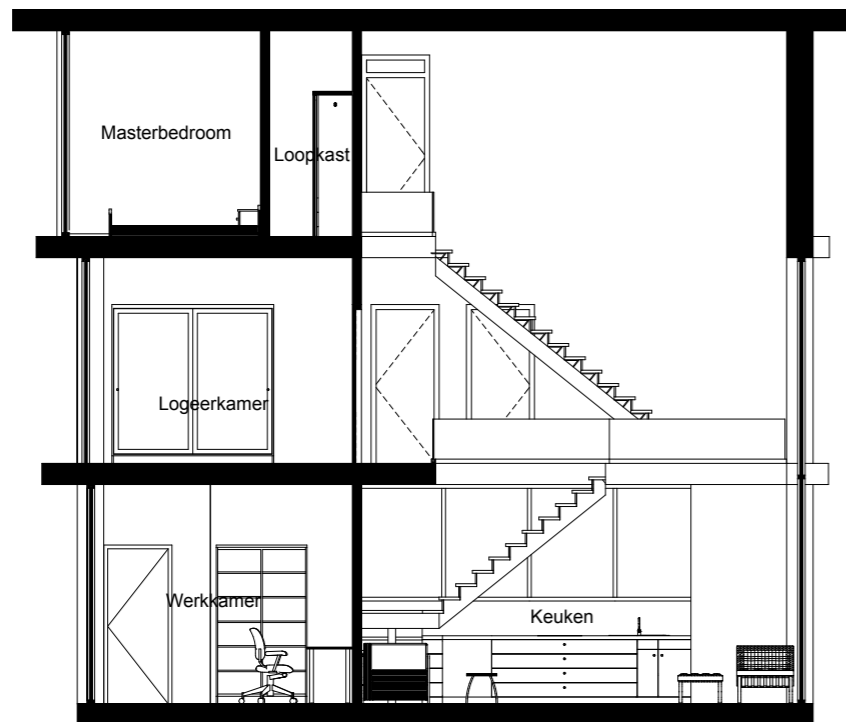

Doorsnede A-A

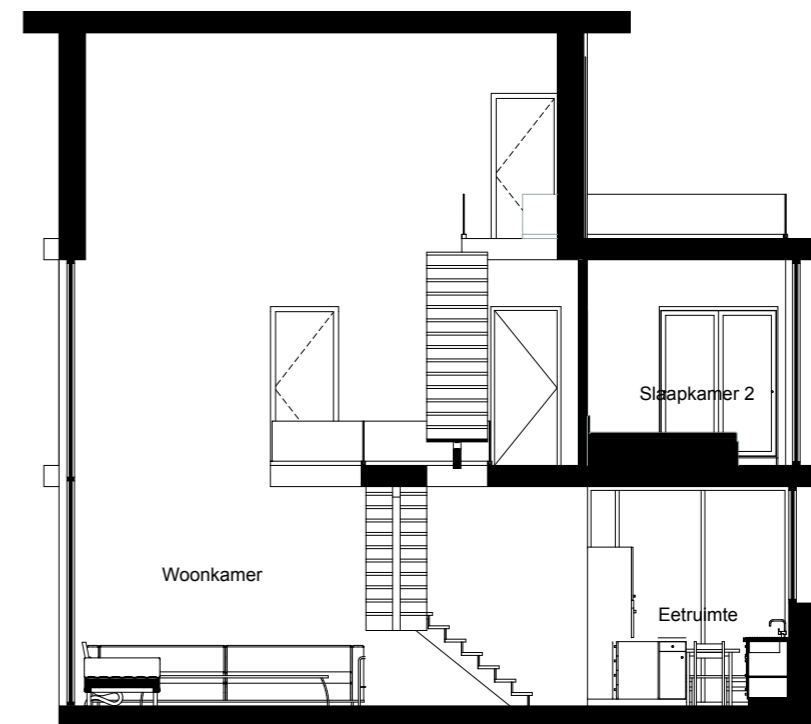

Doorsnede B-B

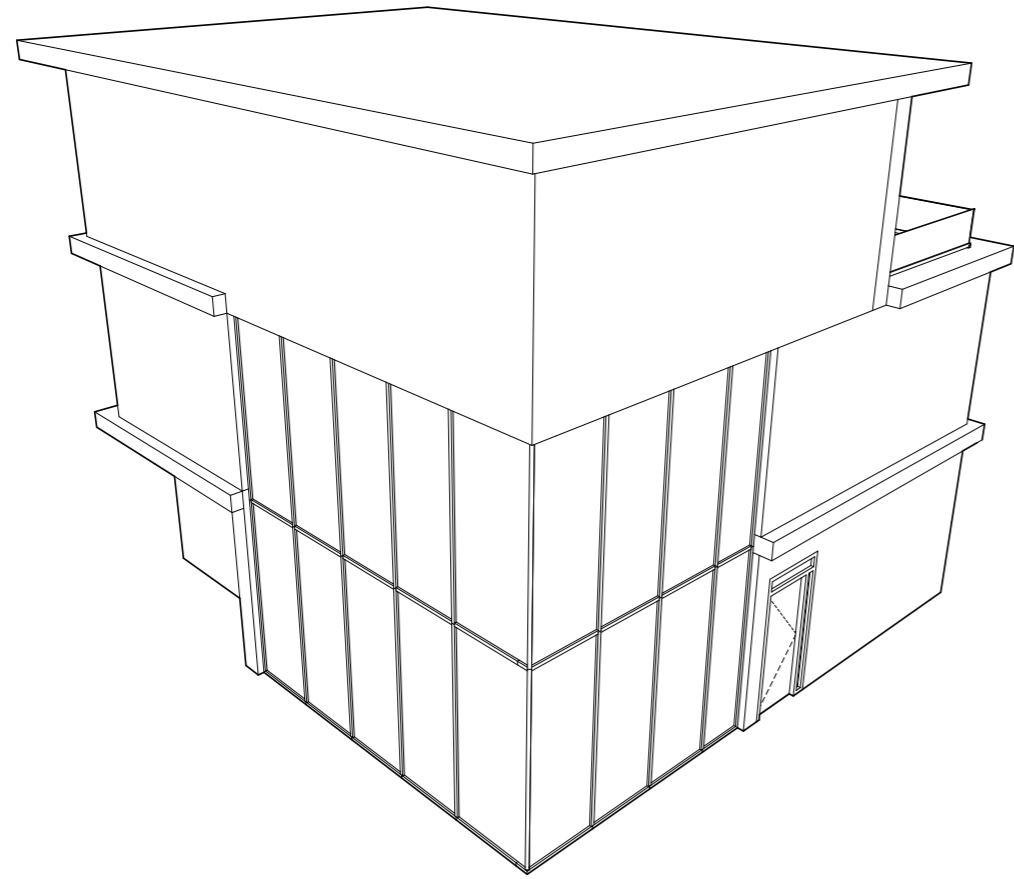

Isometrie

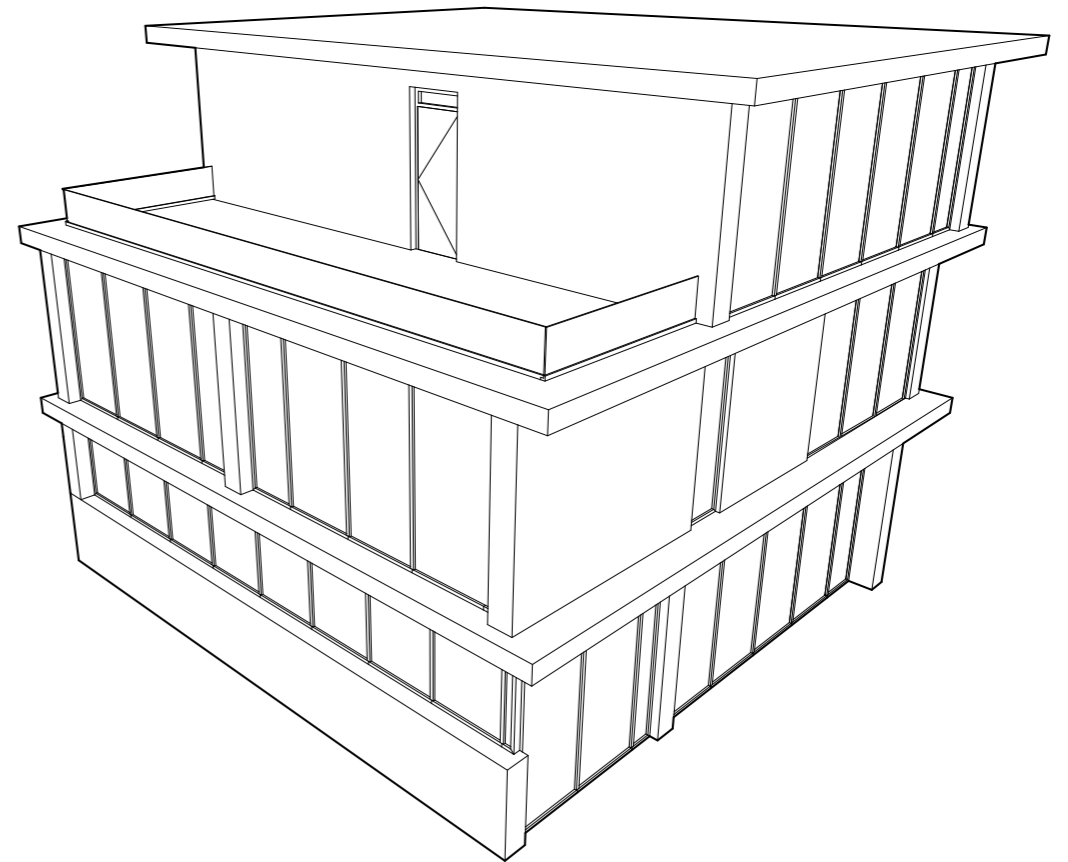

Isometrie

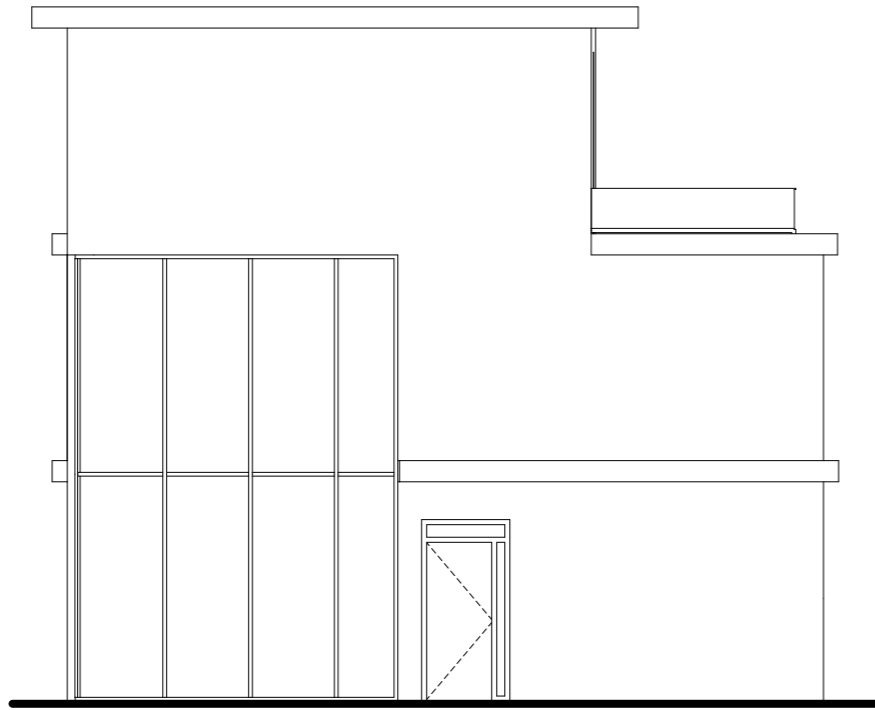

Voorgevel

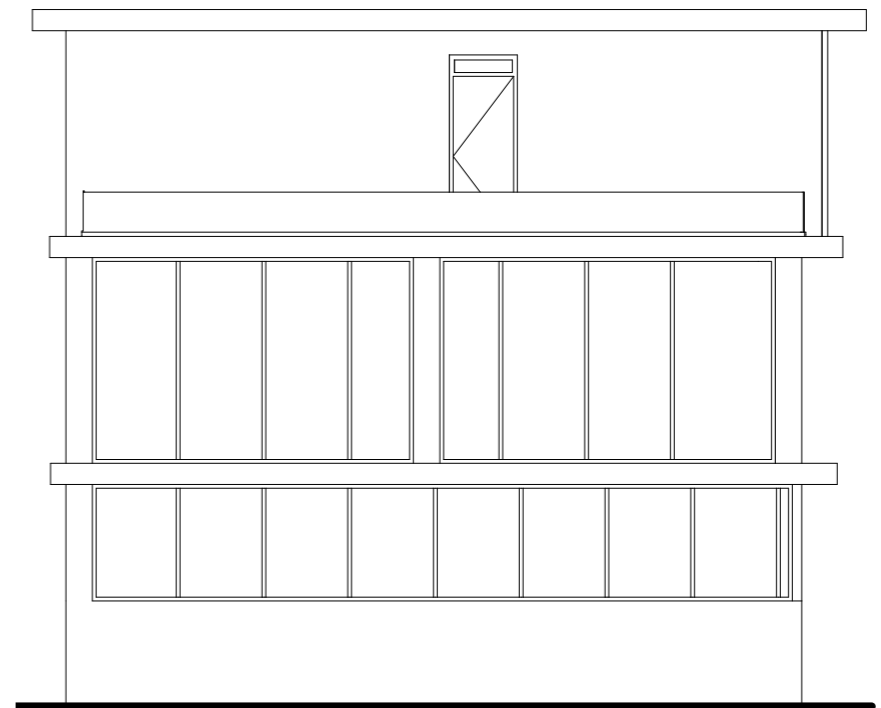

Rechter zijgevel

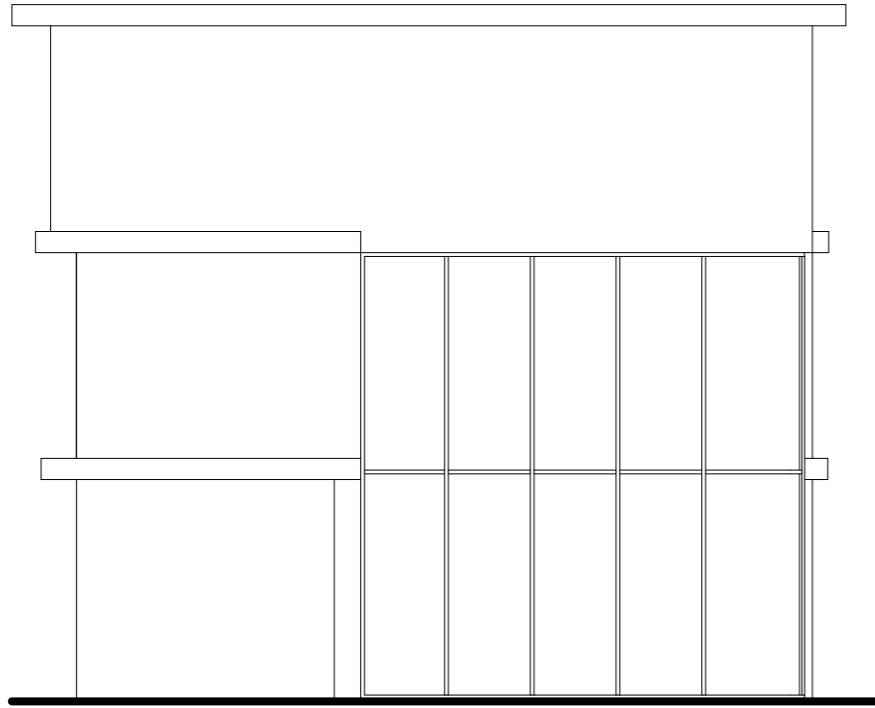

Achtergevel

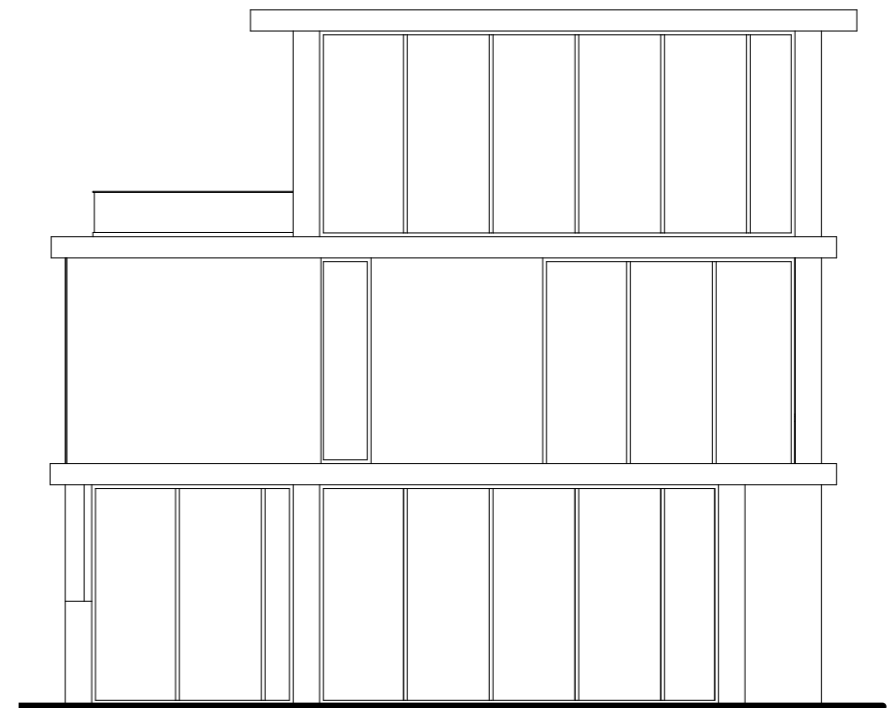

Linker zijgevel

HUIS II

Het huis heeft geen openingen aan de buitenkant, op de voordeur na, die zich op 4,75 meter boven het maaiveld bevindt.

Concept: Patio Huis

Uitgangspunten:

- 1- Licht binnenvallen.
- 2- Patio
- 2- Zichtlijnen

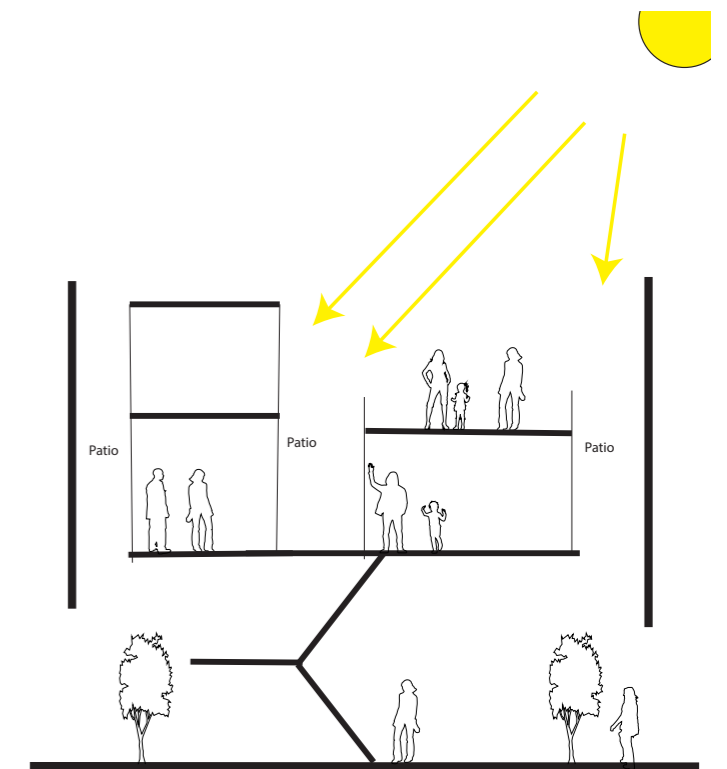
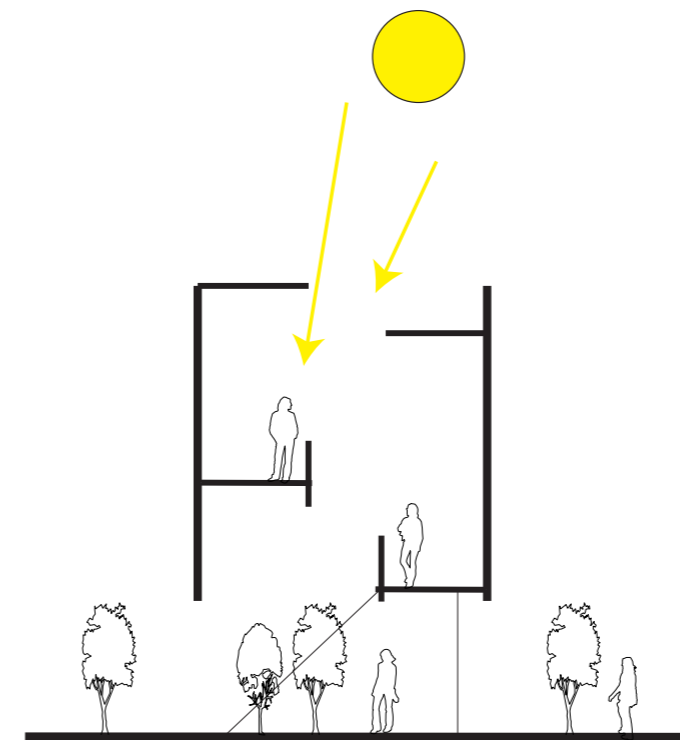
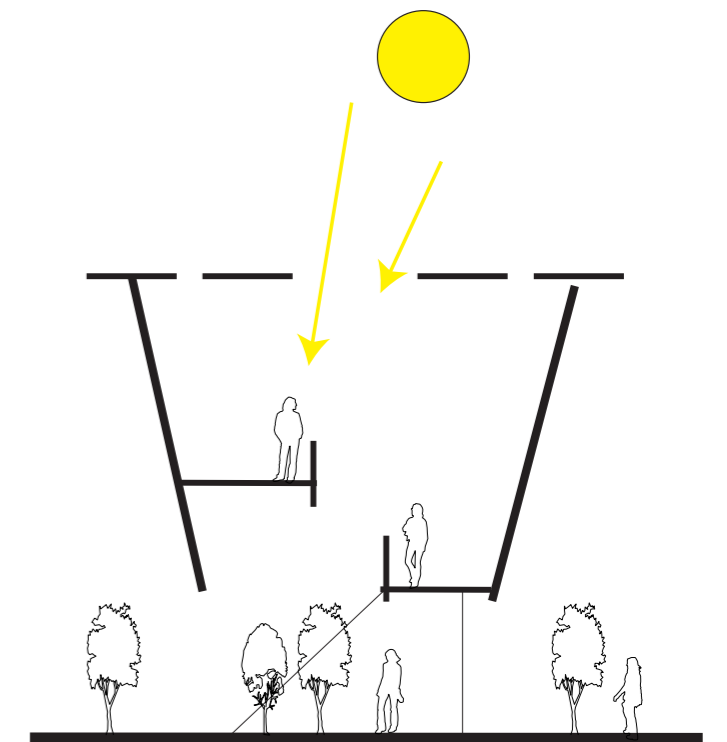
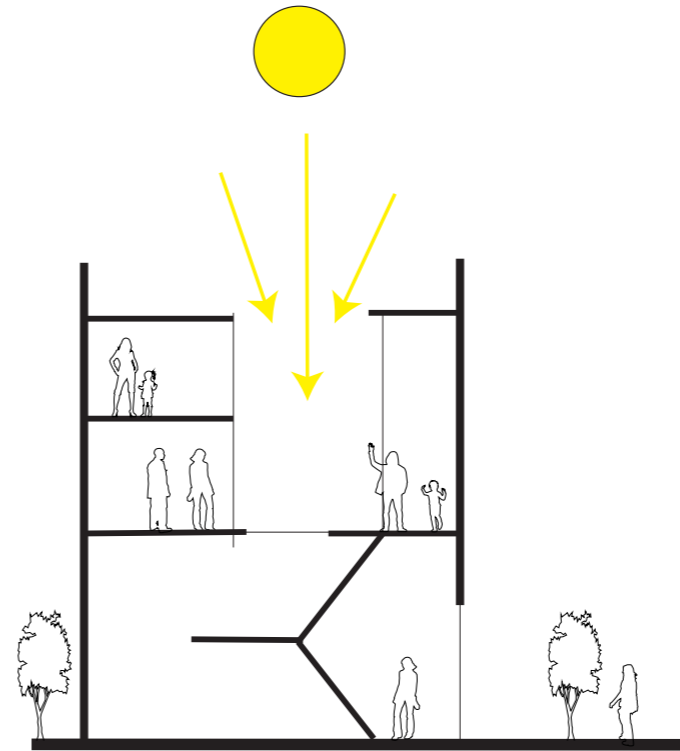

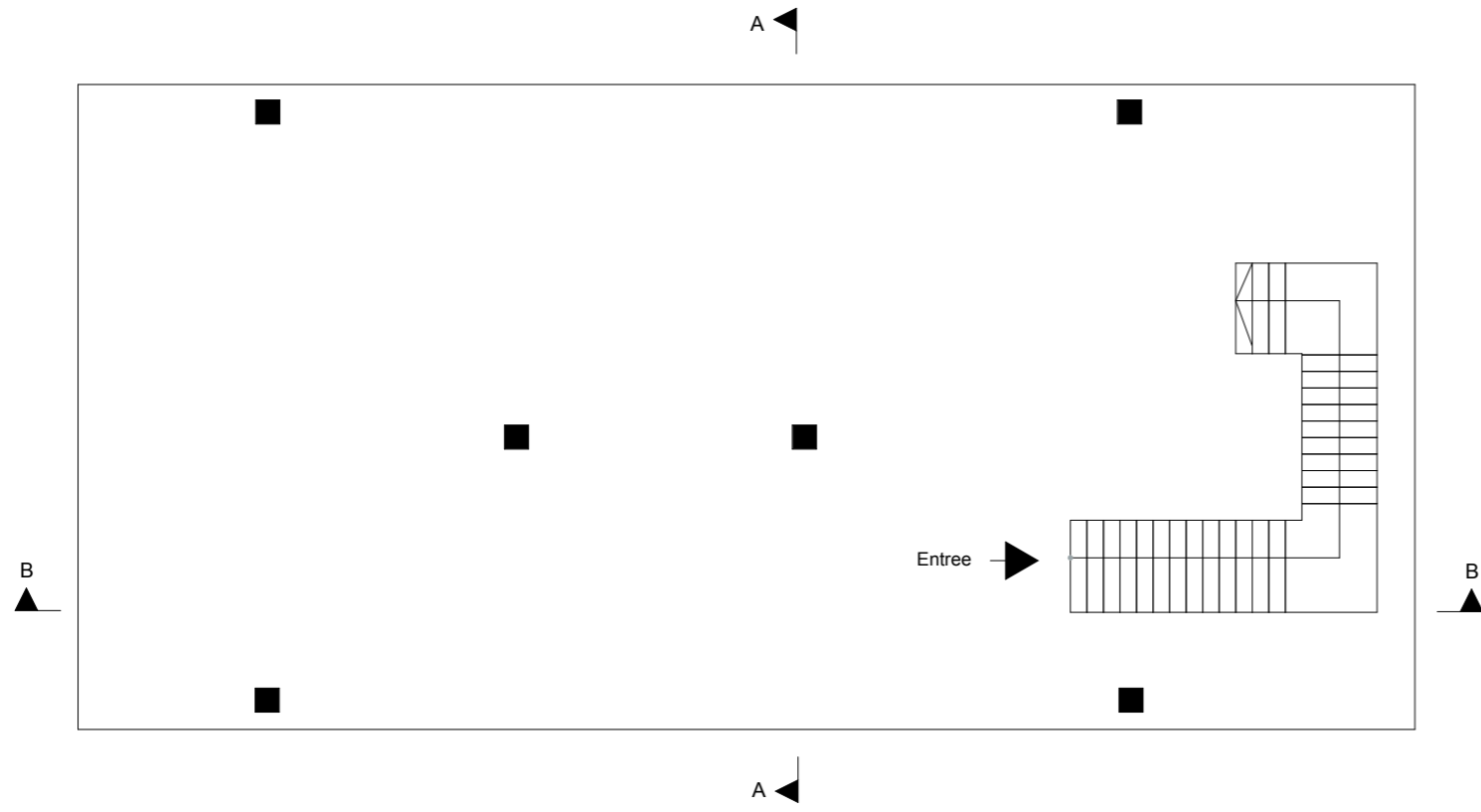

Beganegrond

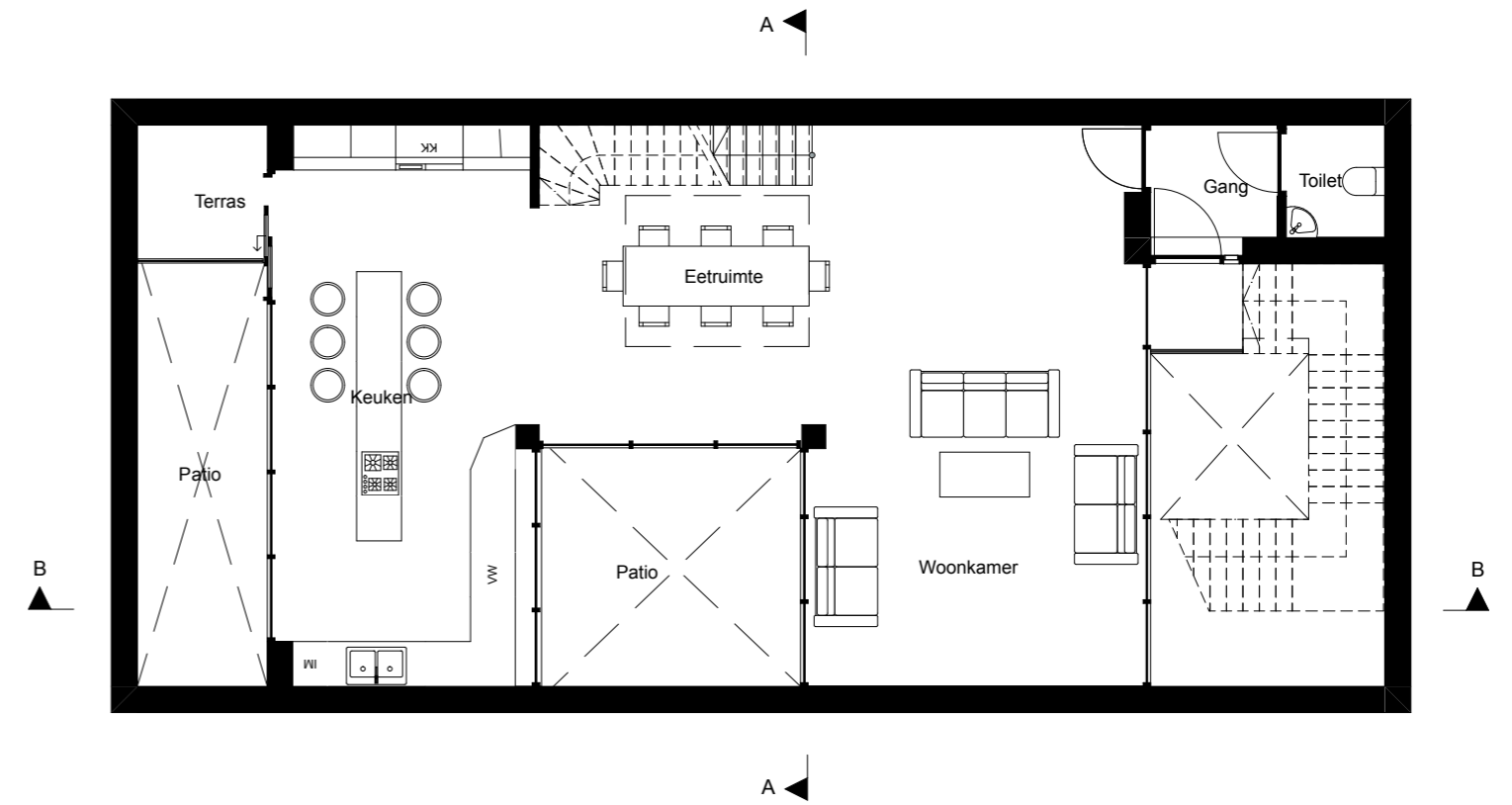

1e Verdieping

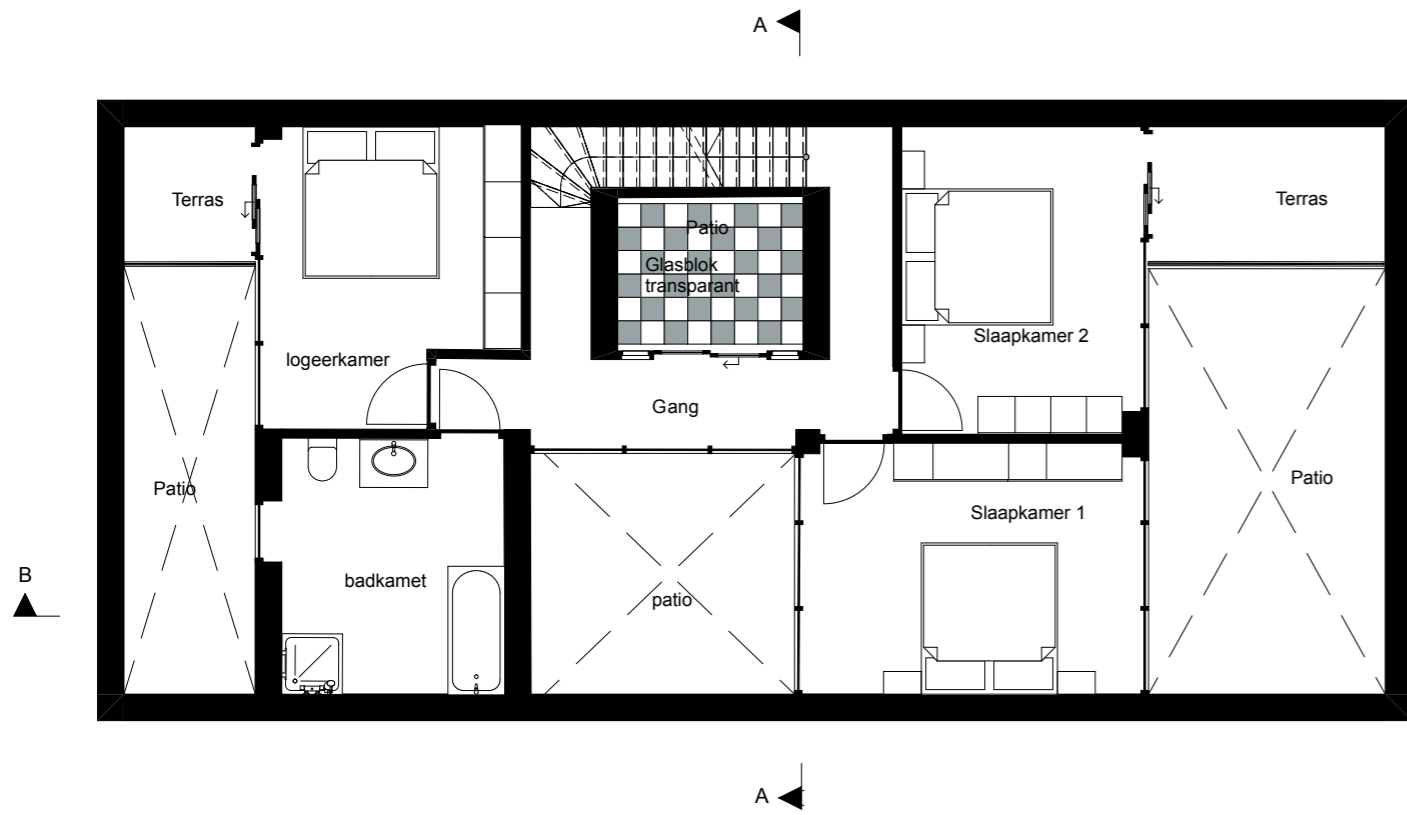

2e Verdieping

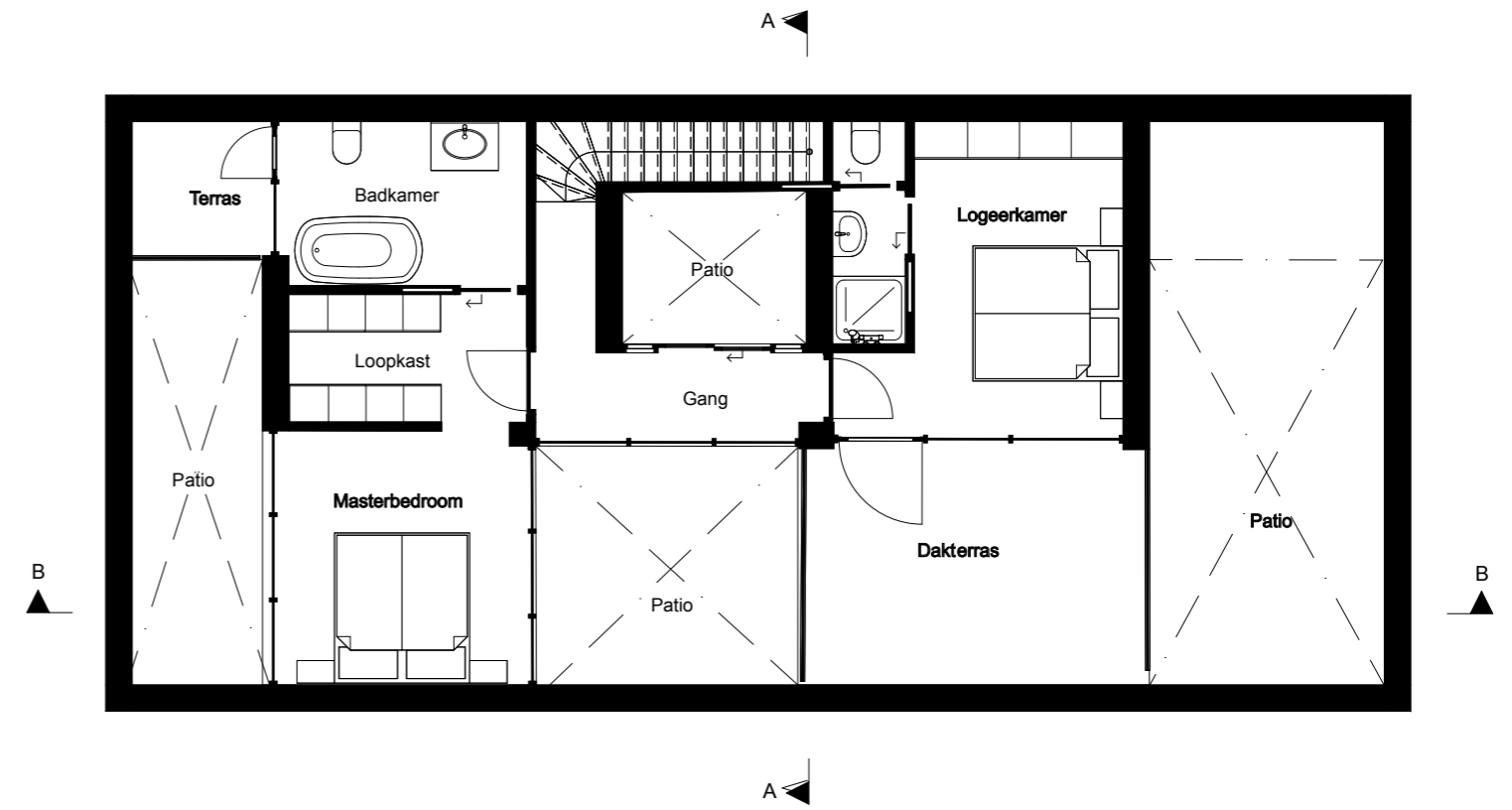

3e Verdieping

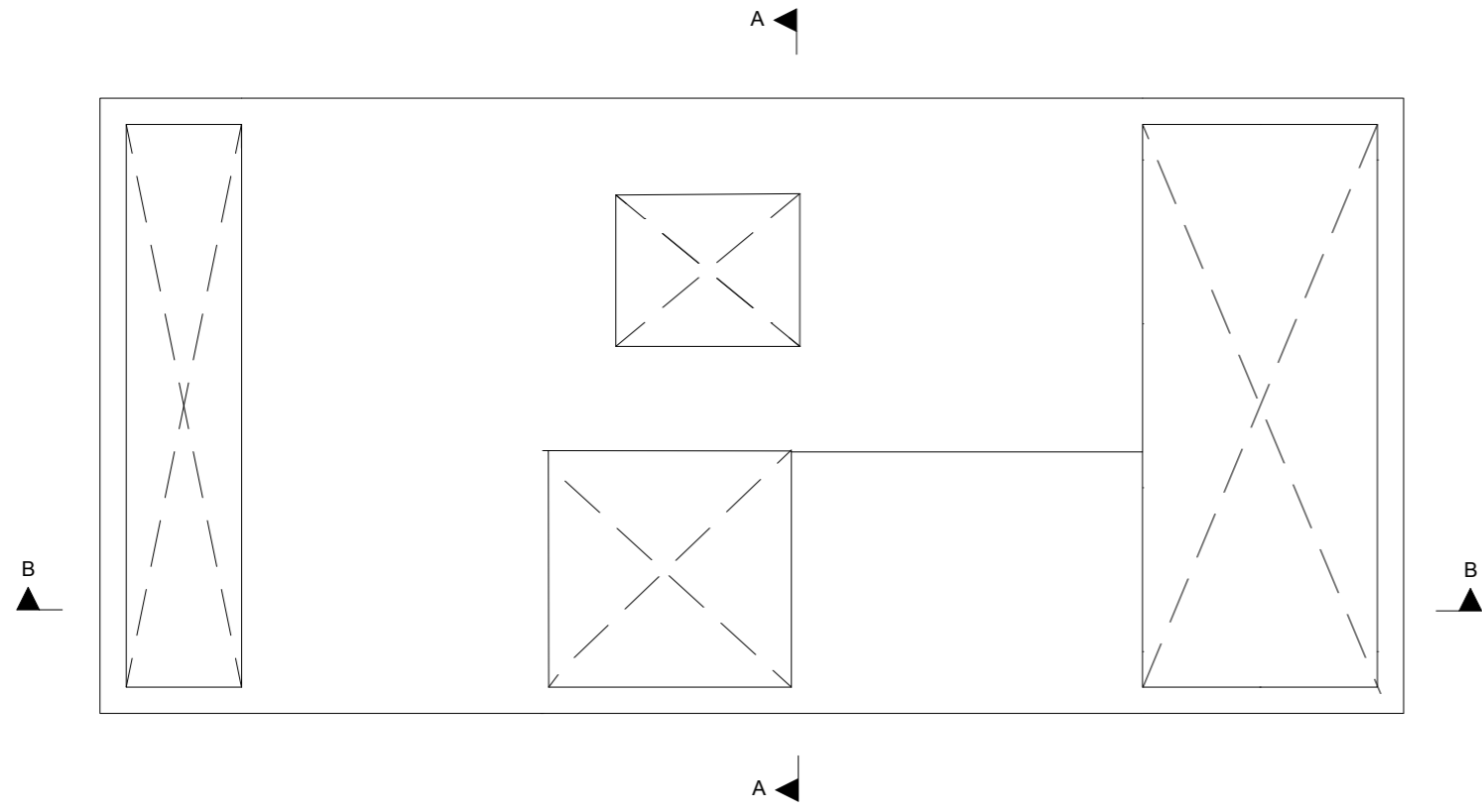

Dakaanzicht

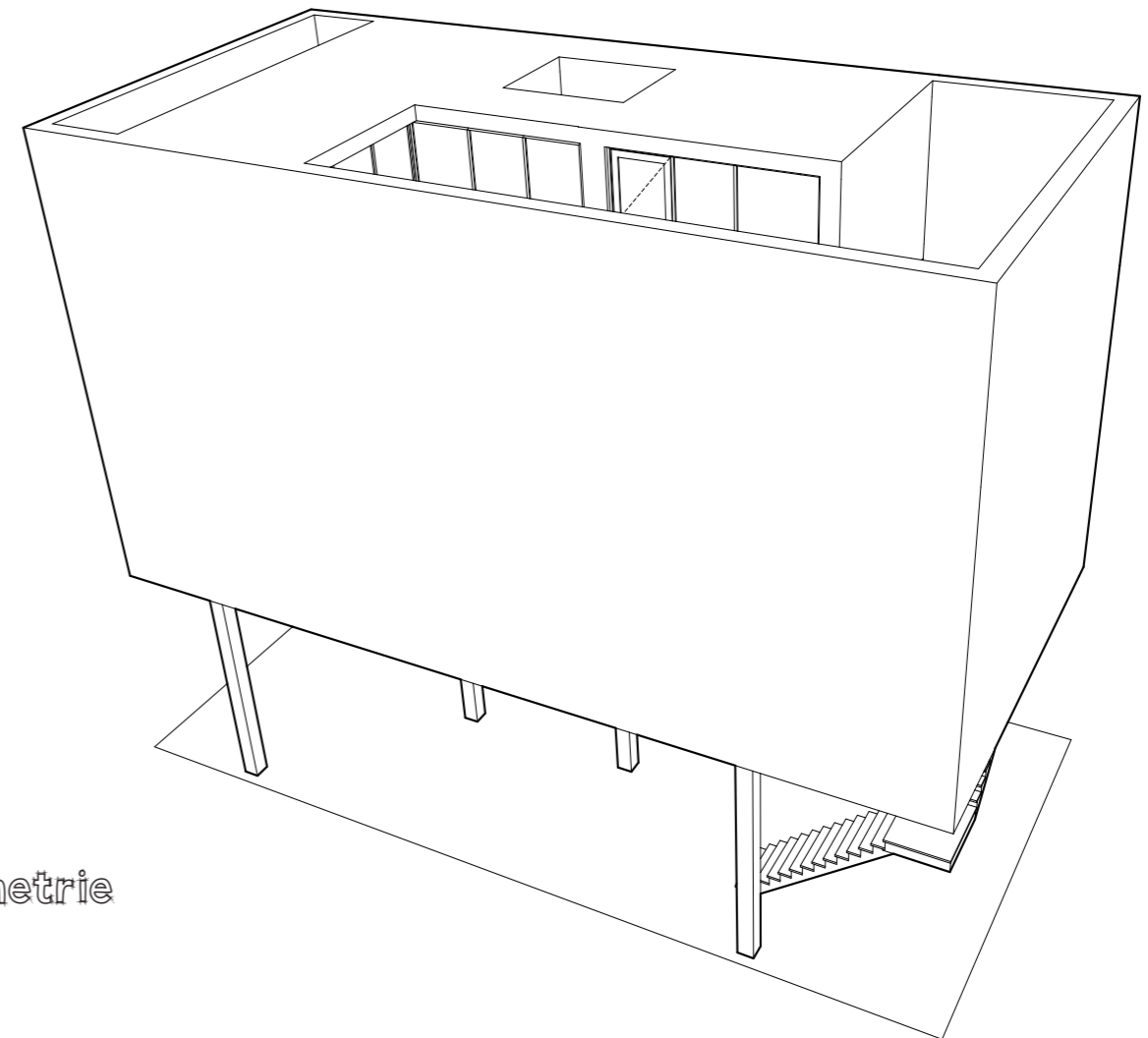

Isometrie

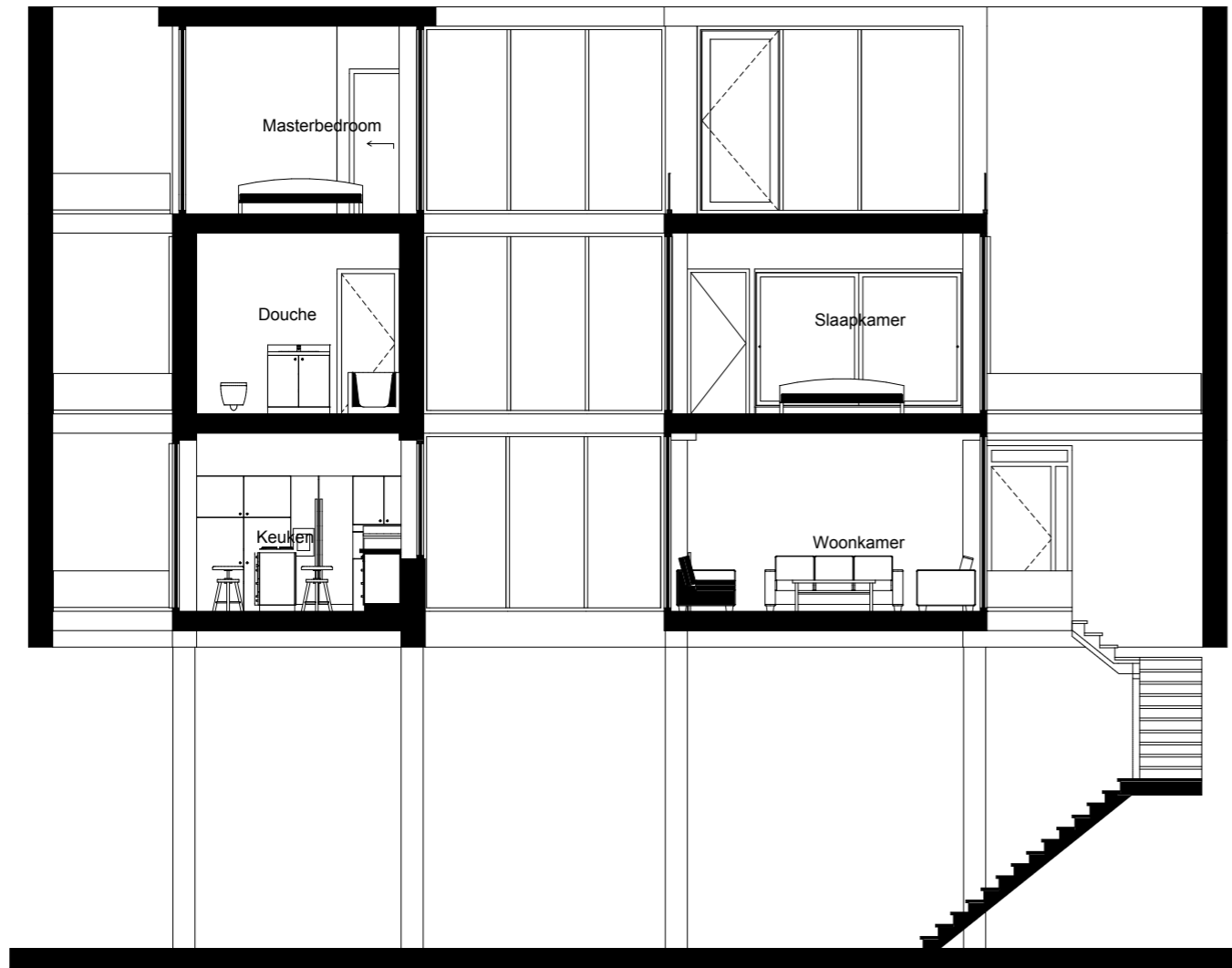

Doorsnede A-A



Doorsnede B-B

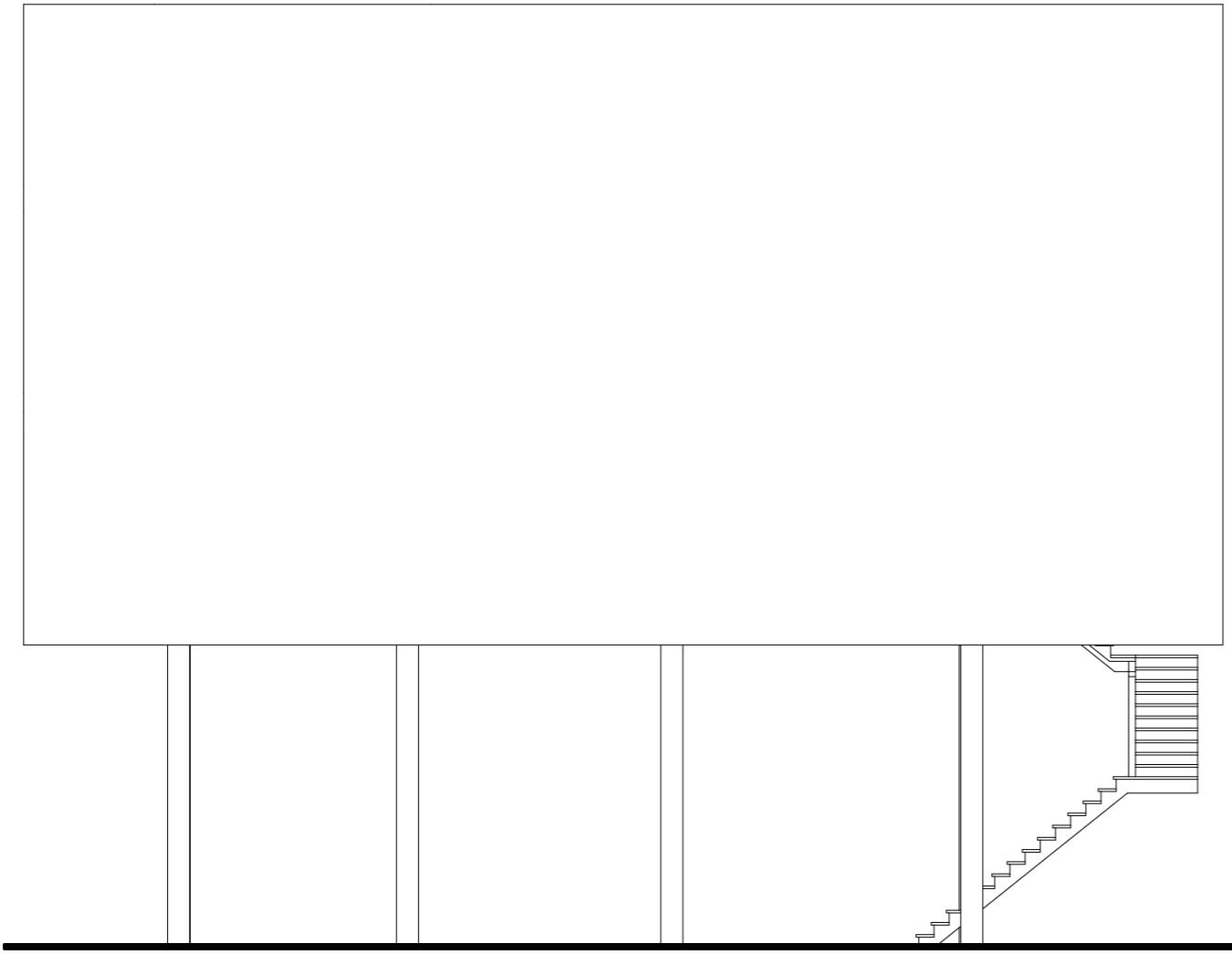

Doorsnede A-A

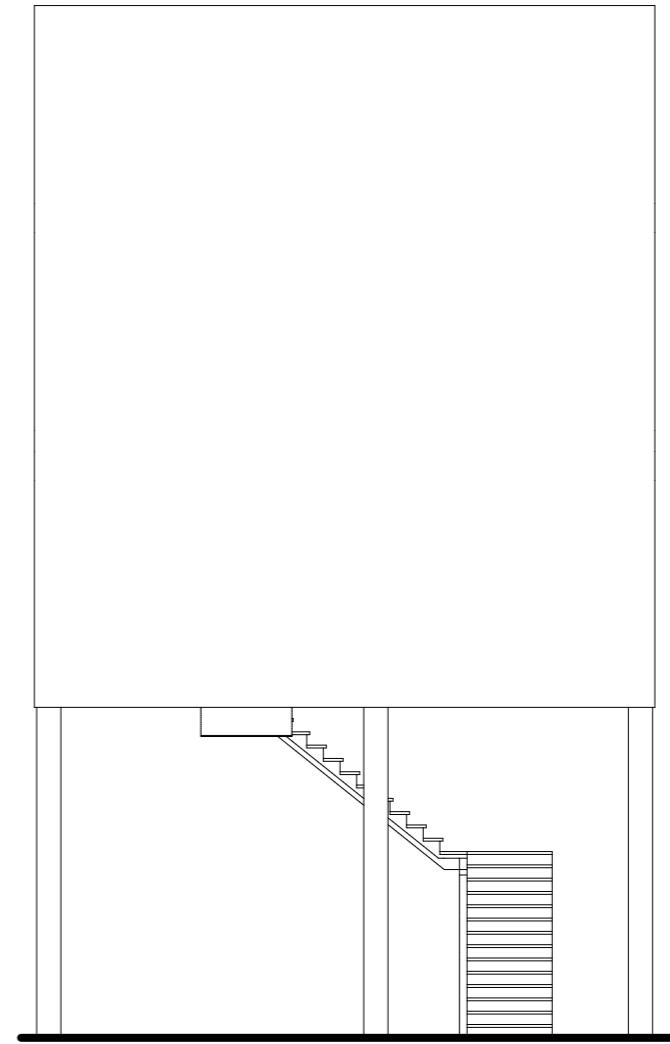

Doorsnede B-B

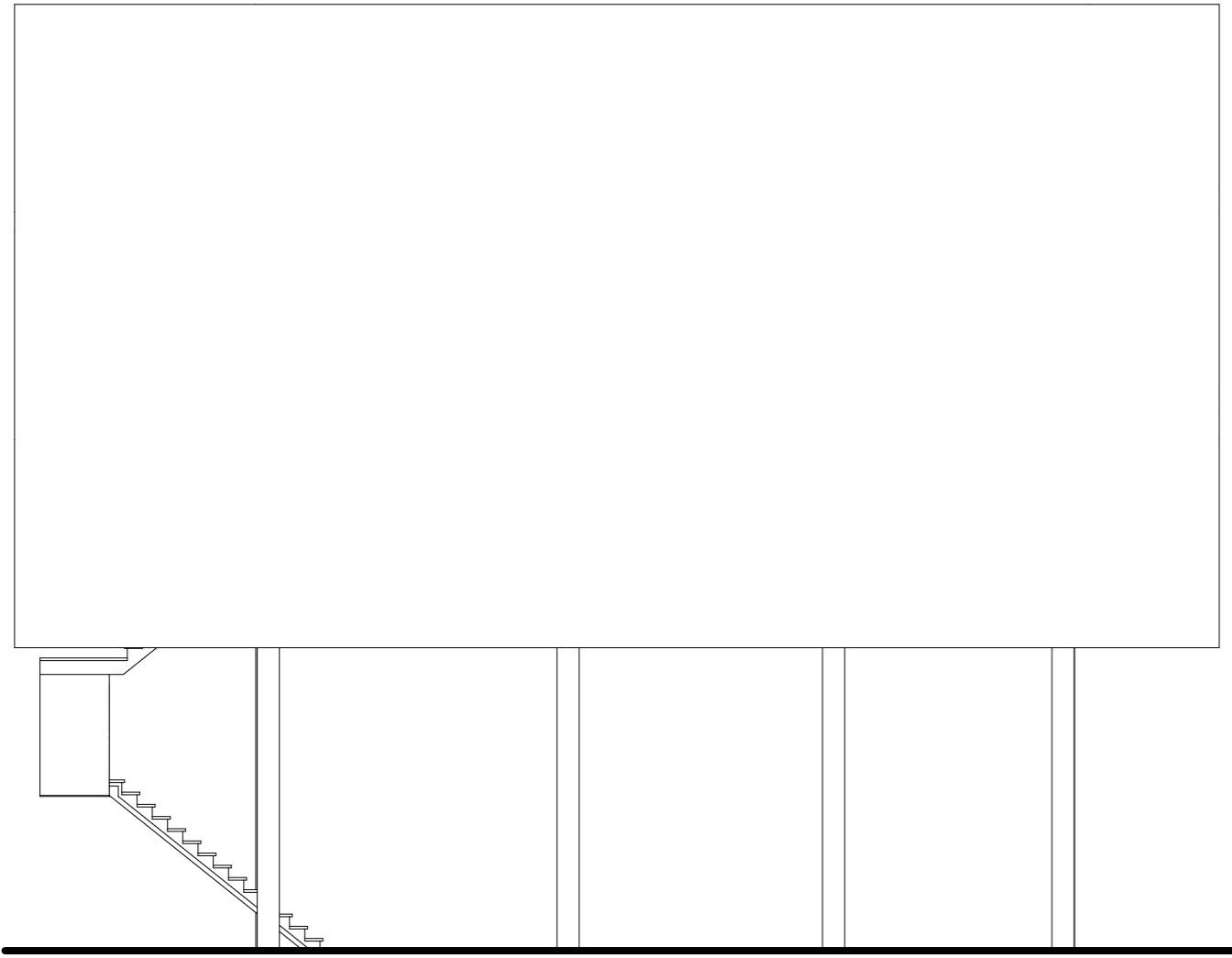

Doorsnede A-A

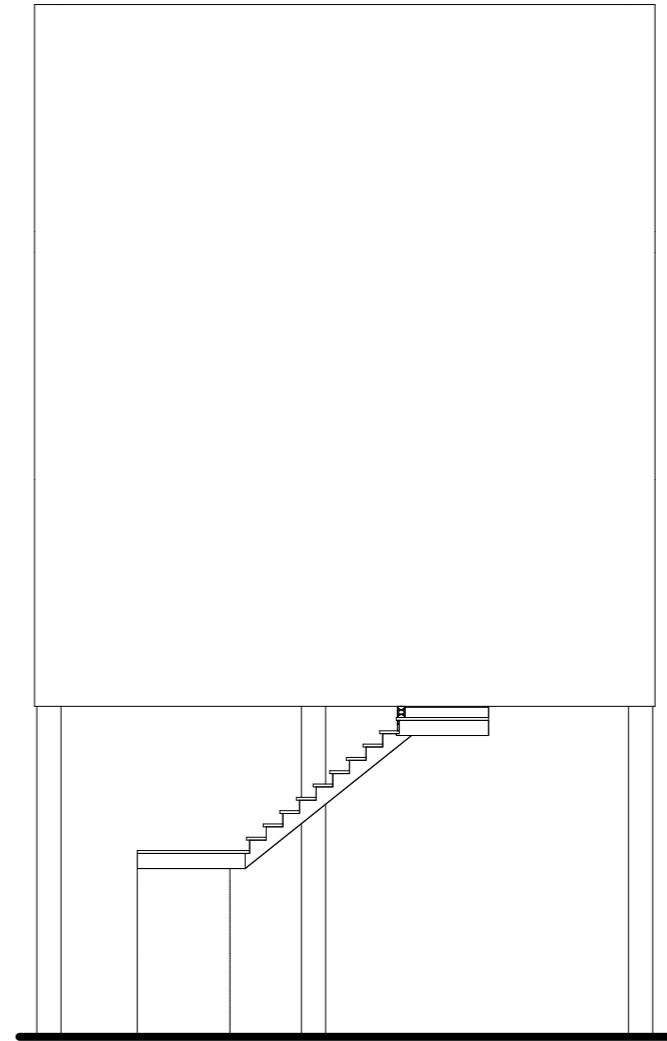

Doorsnede B-B

HUIS III

Het huis heeft een zwembad van 12,5 x 3 meter.

Concept: Blauwe wereled

Uitgangspunten: 4 Aspecten

- 1- In het - Zwembad
- 2- Onder - Zwembad
- 3- Naast / Voor - Zwembad
- 4- Boven - Zwembad

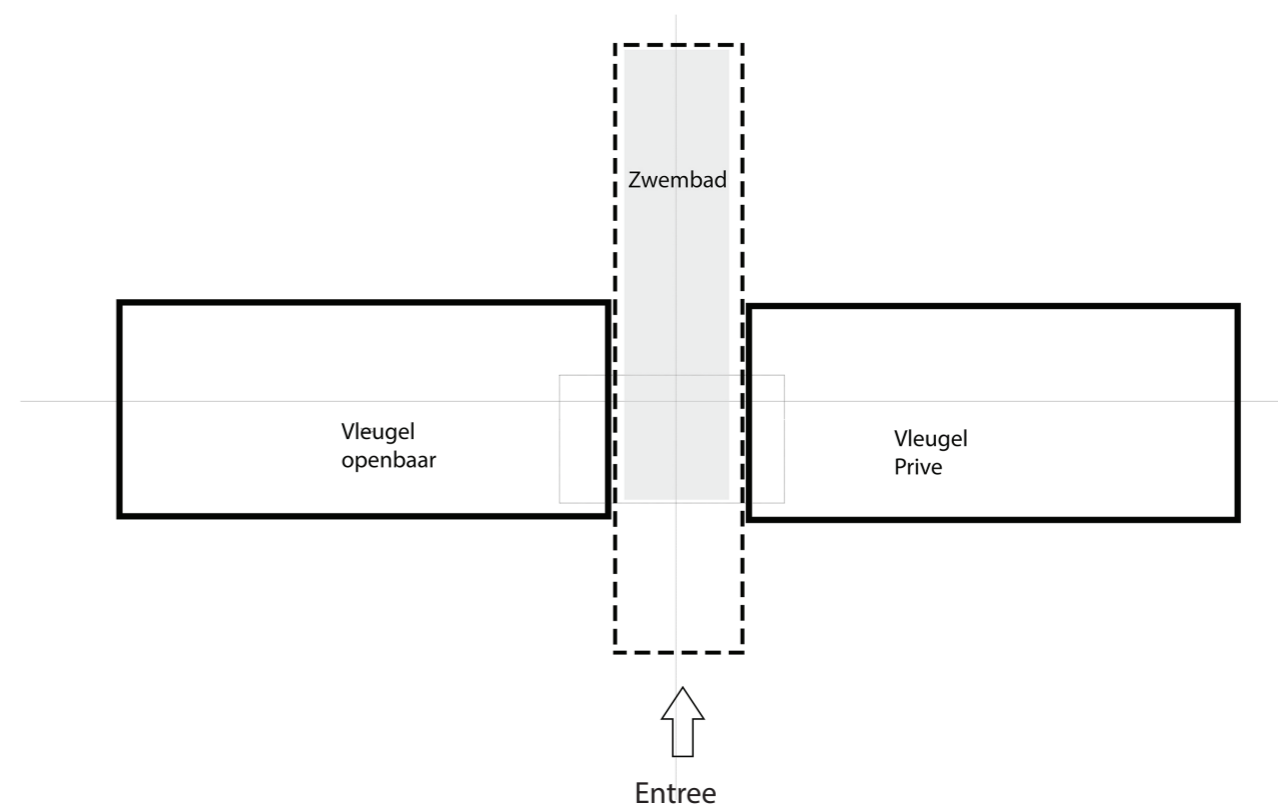
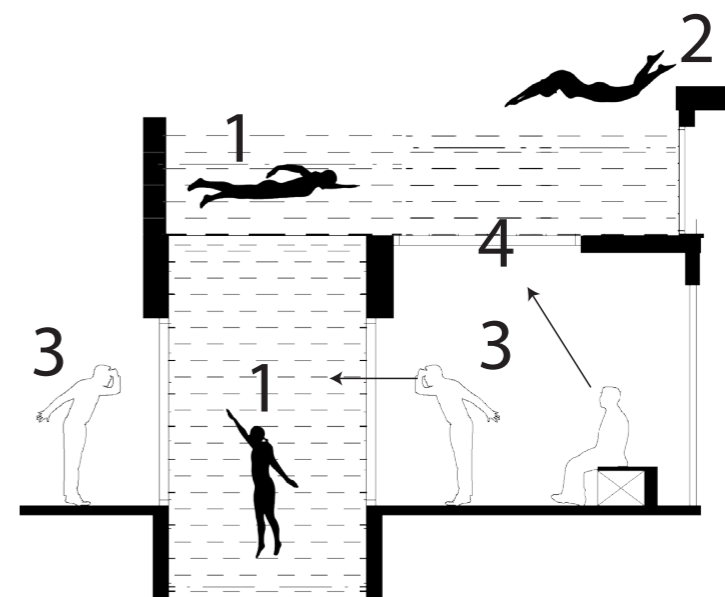

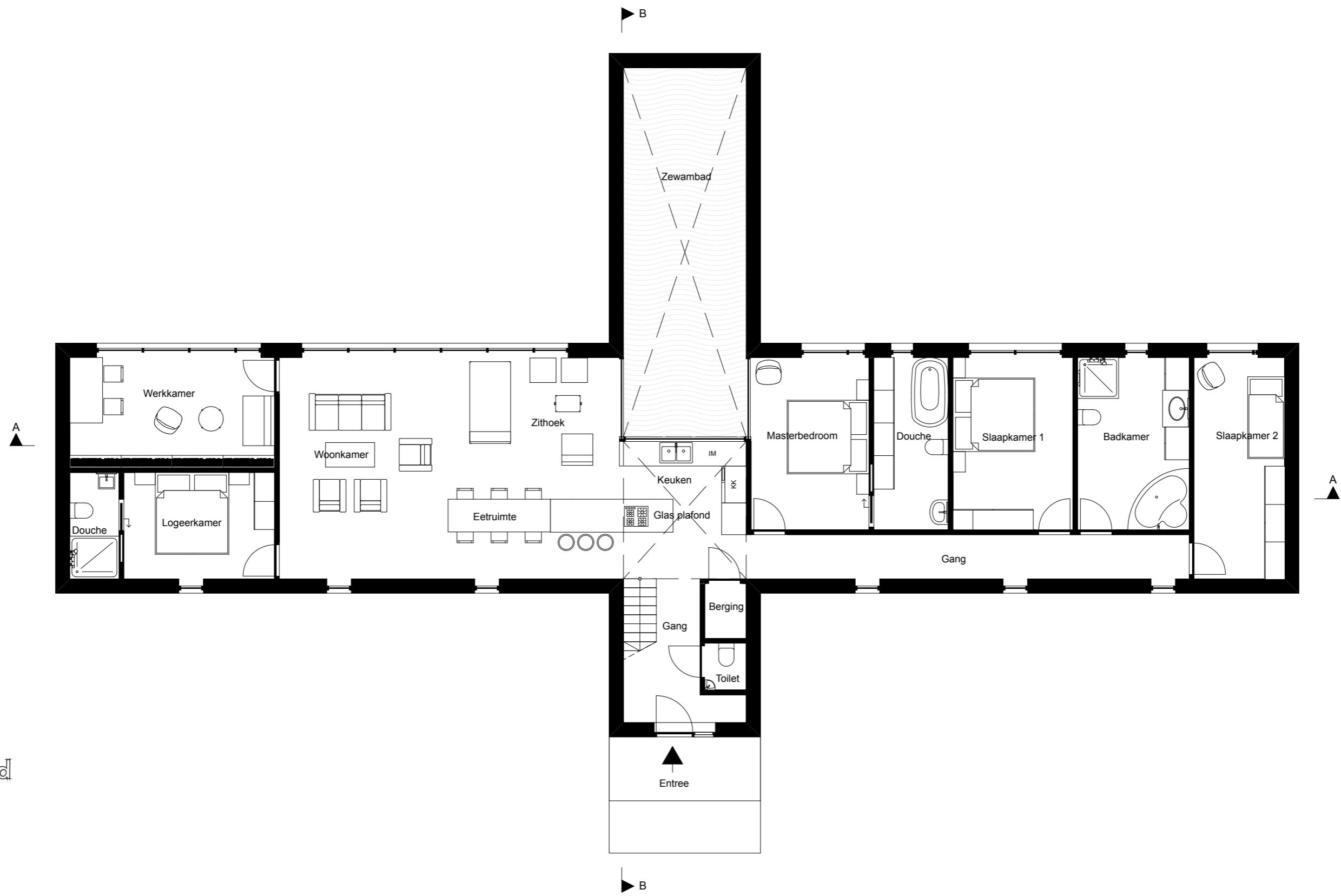

Bagnegrond

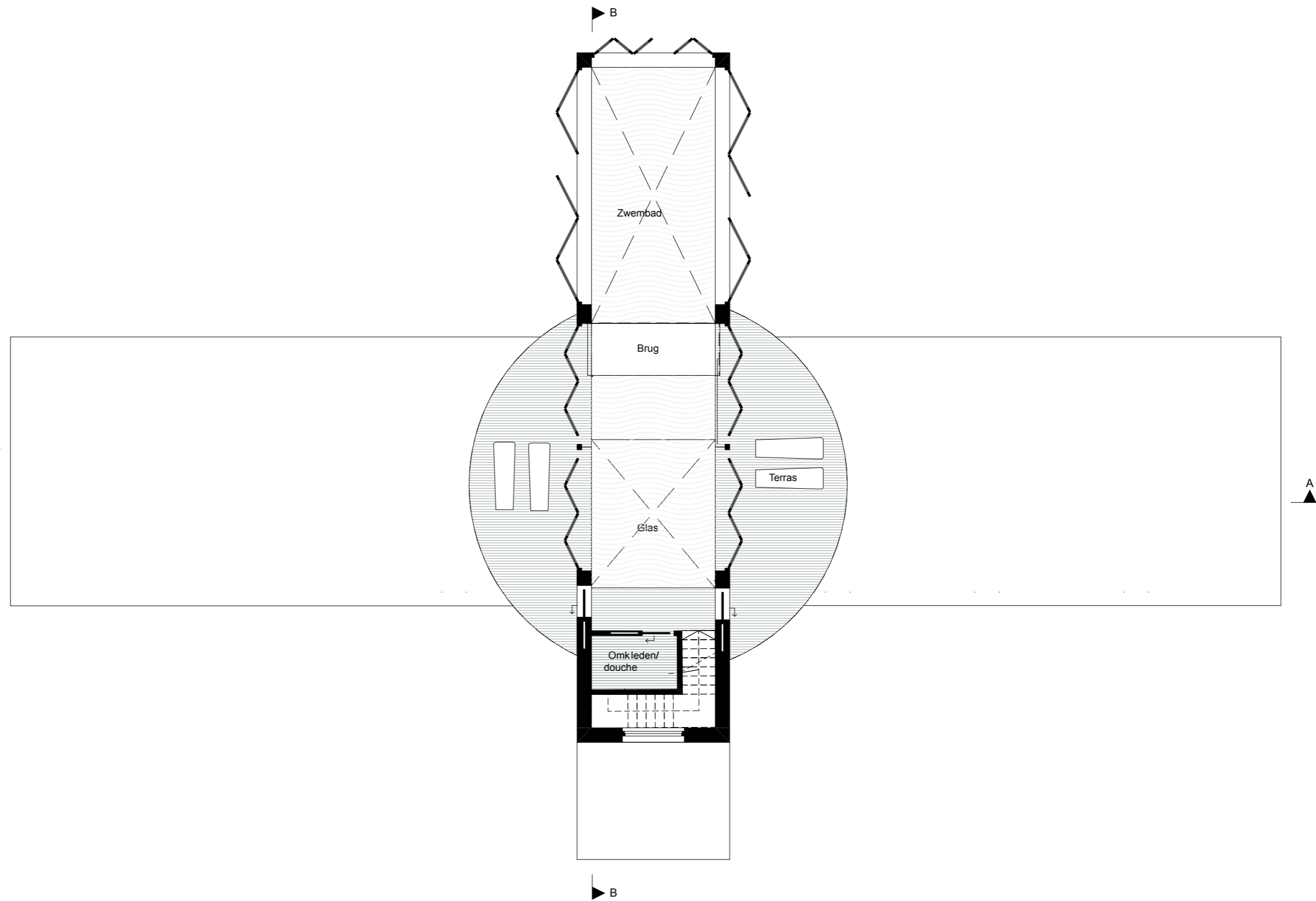

1e Verdieping

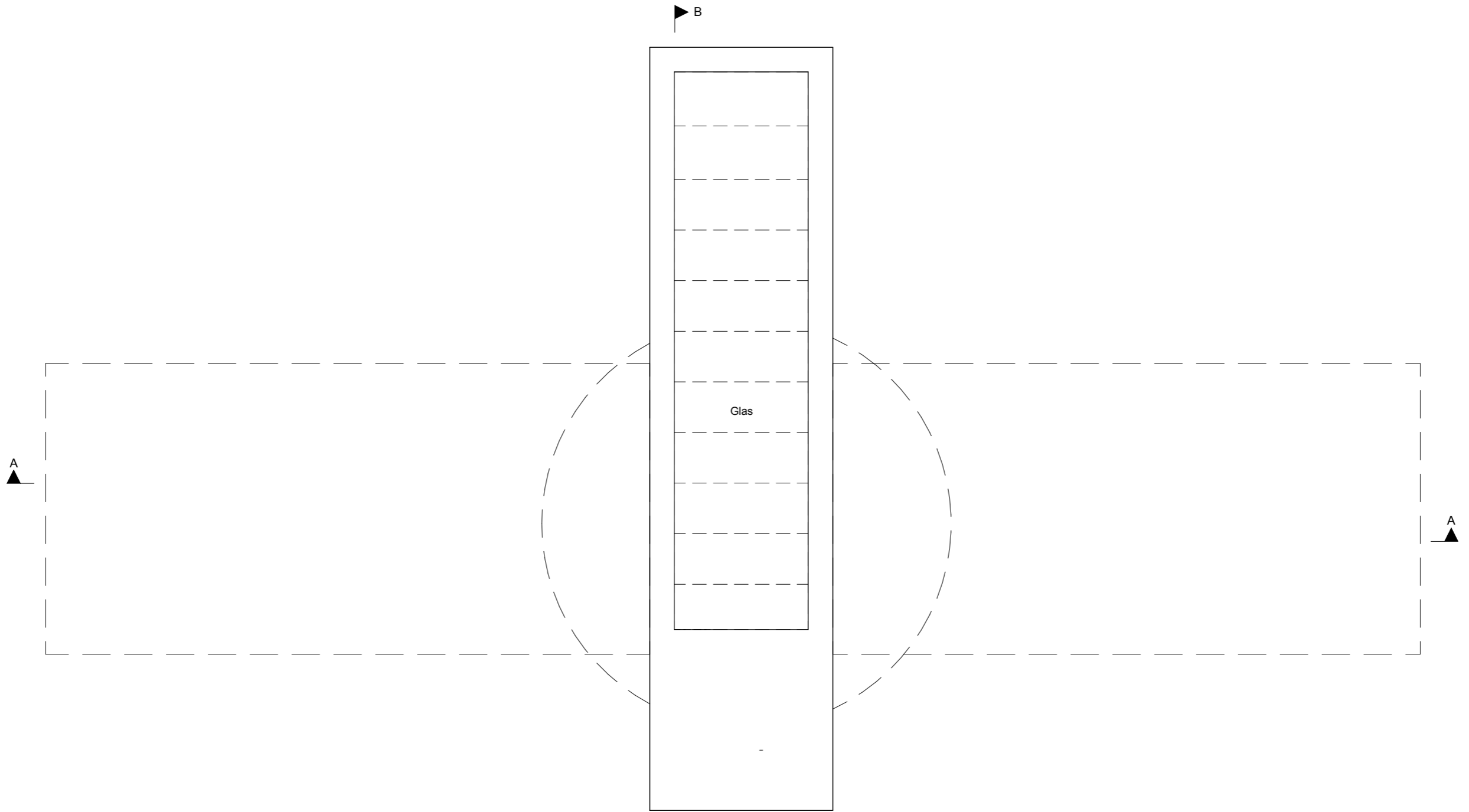

Dakaanzicht

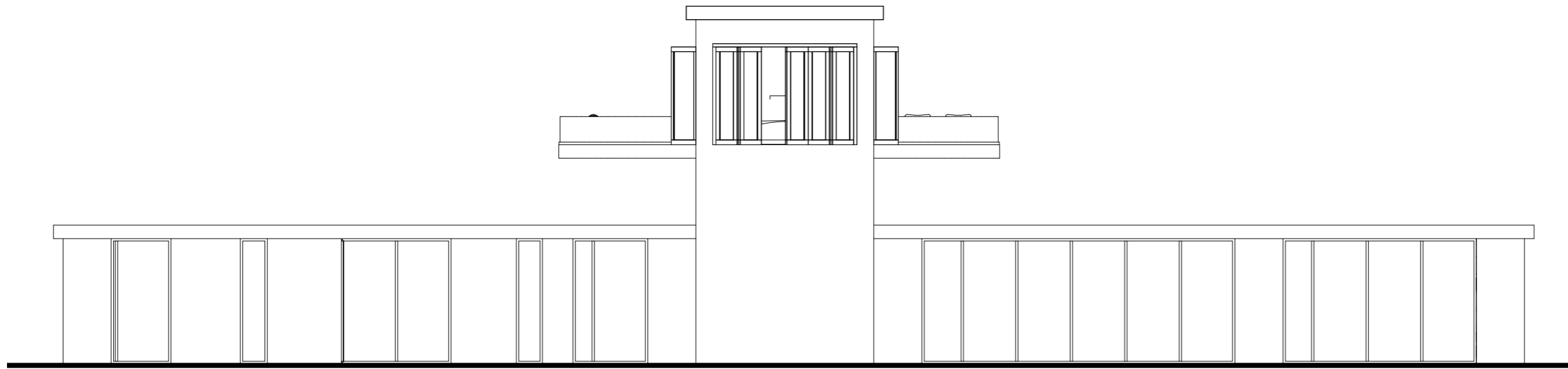

Voorgevel

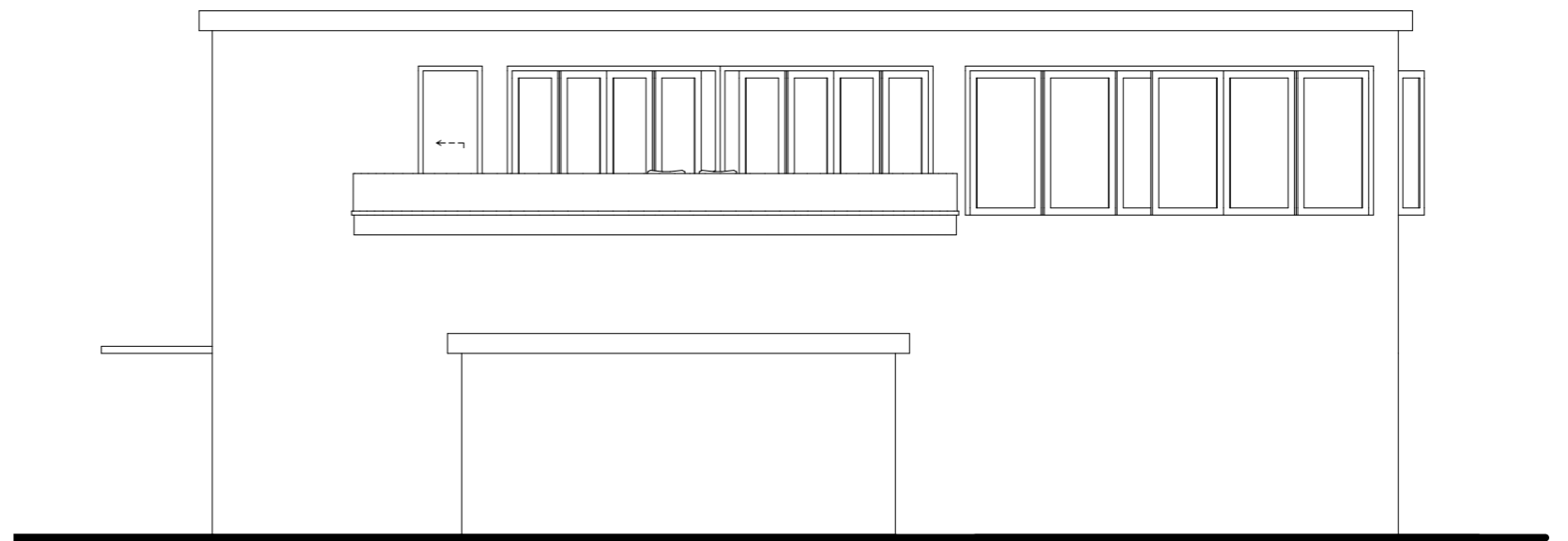

Rechter zijgevel

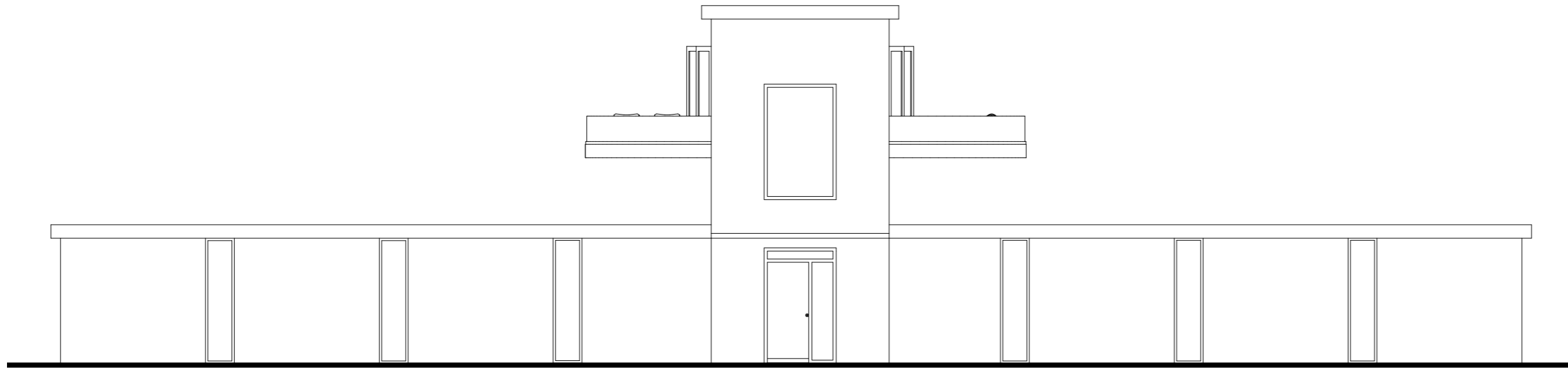

Achtegevel

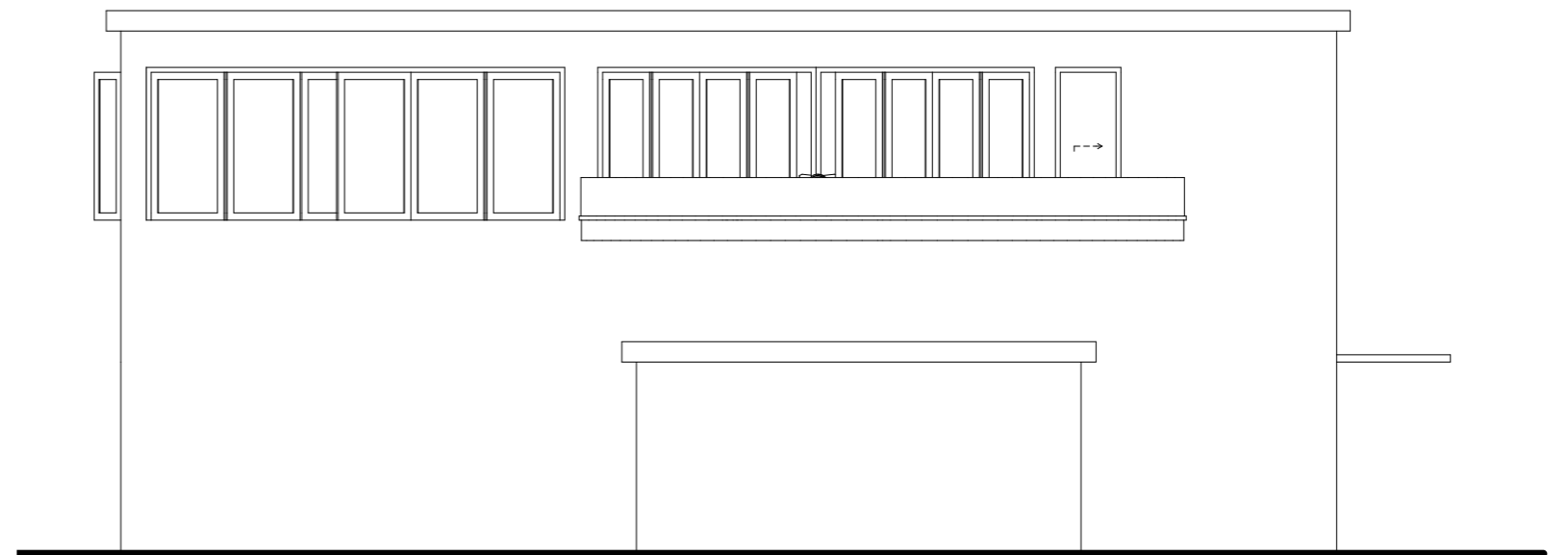

Linker zijgevel

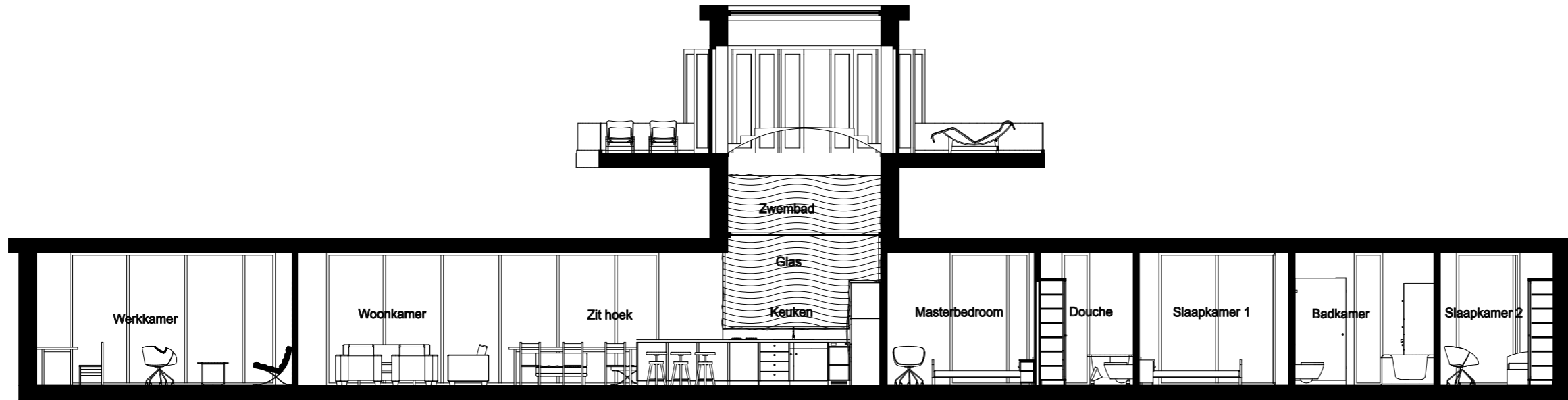

Doorsnede A-A

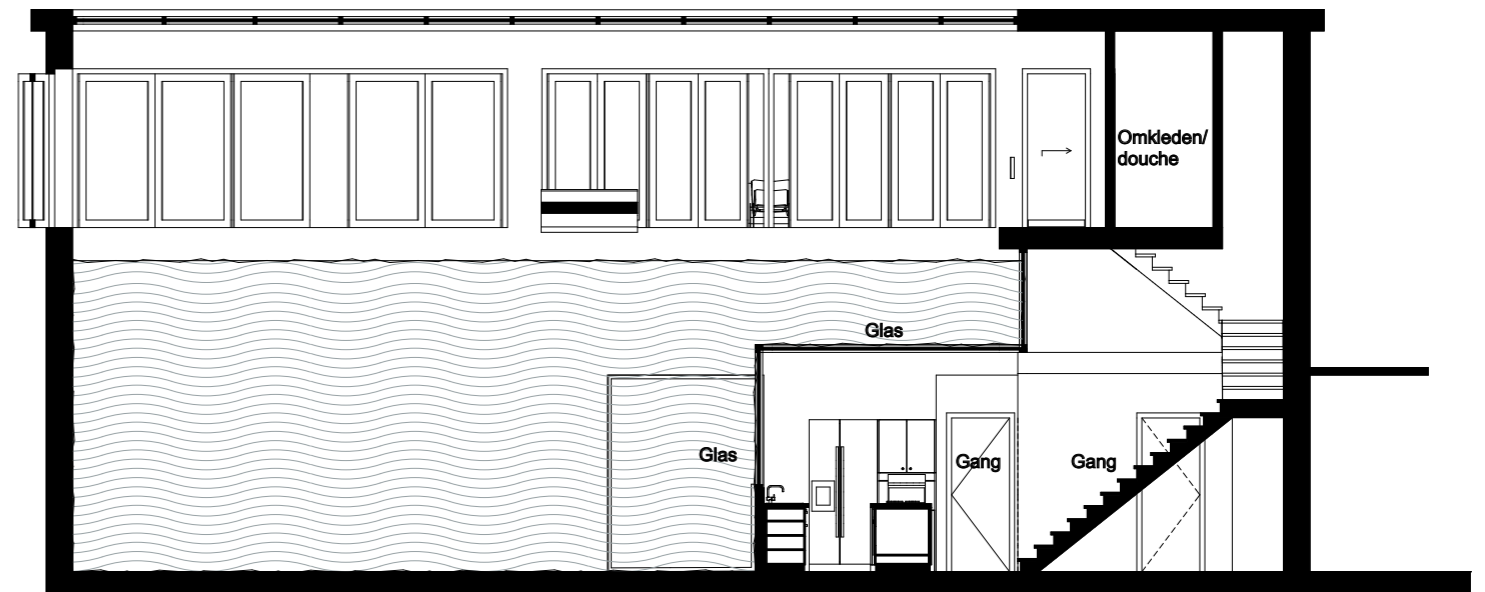

Doorsnede B-B

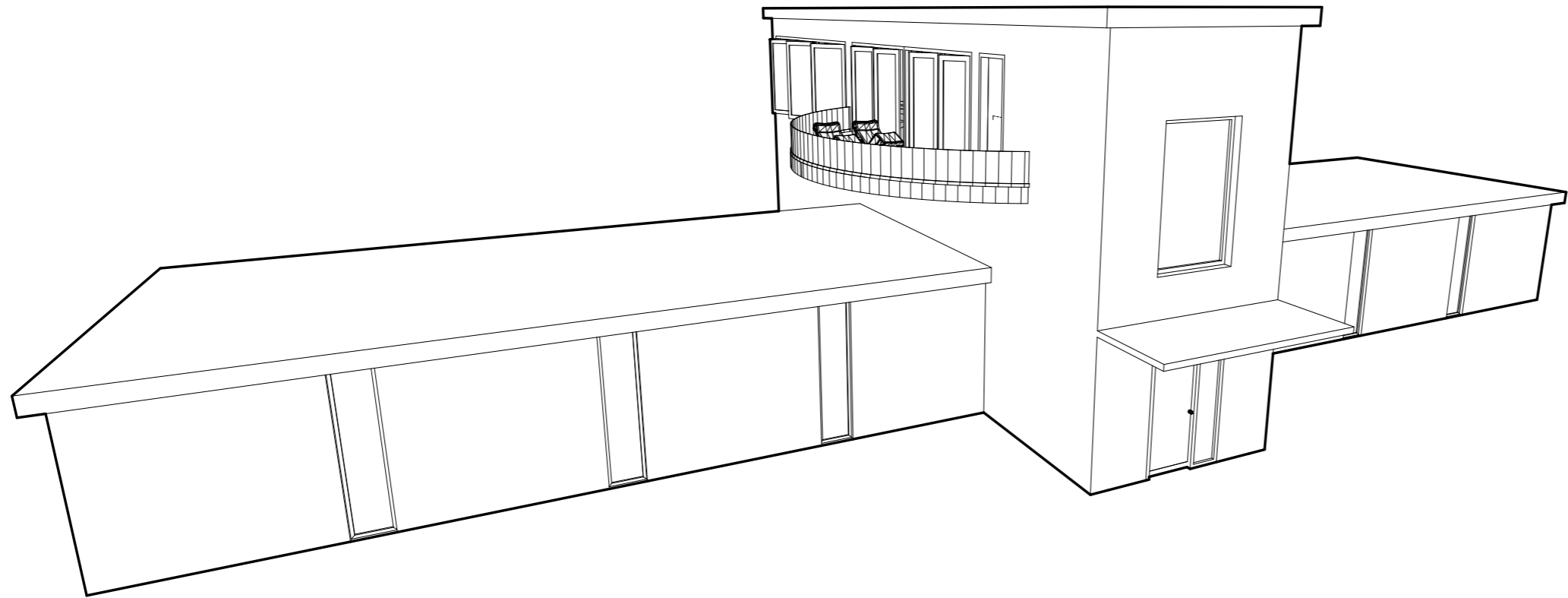

Isometrie

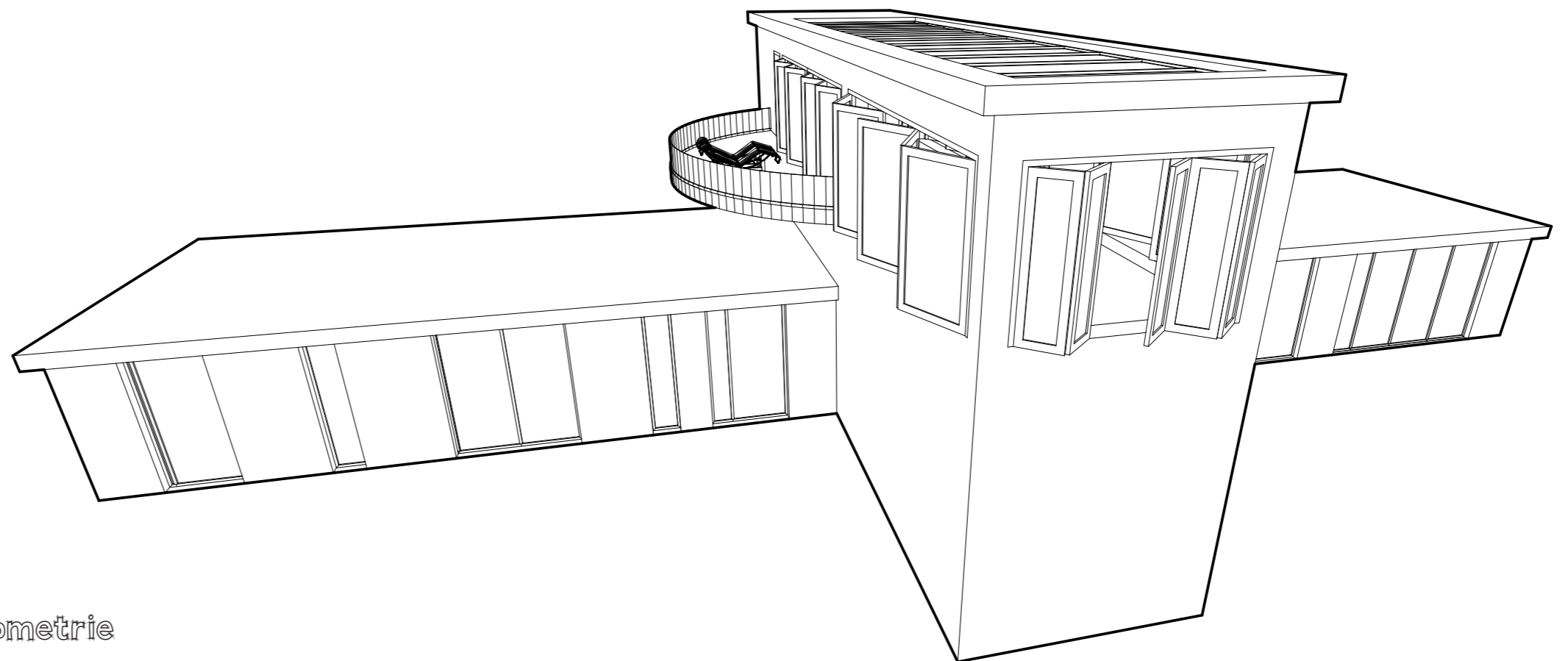

Isometrie

HUIS IV

In het huis is plek voor 250 strekkende meter boeken, die toegankelijk moet zijn.

Concept: Bibliotheek Huis

Uitgangspunten:

- 1- Knus
- 2- Zichtlijnen + boeken
- 3- Focus/werken

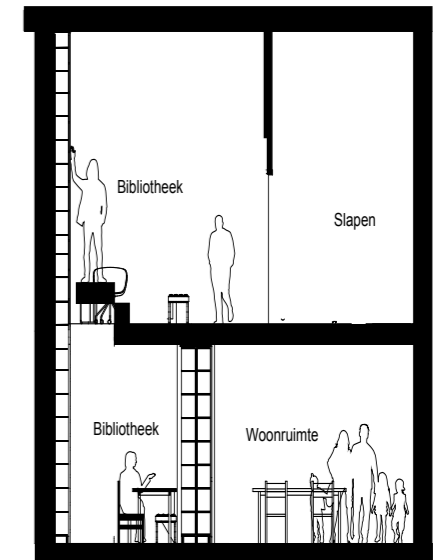
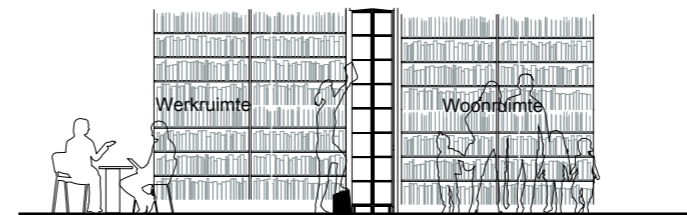
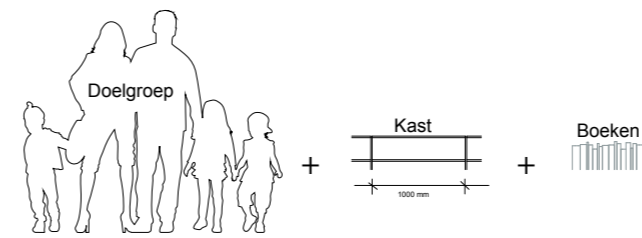
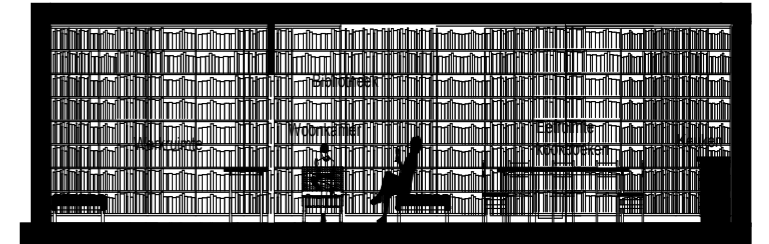

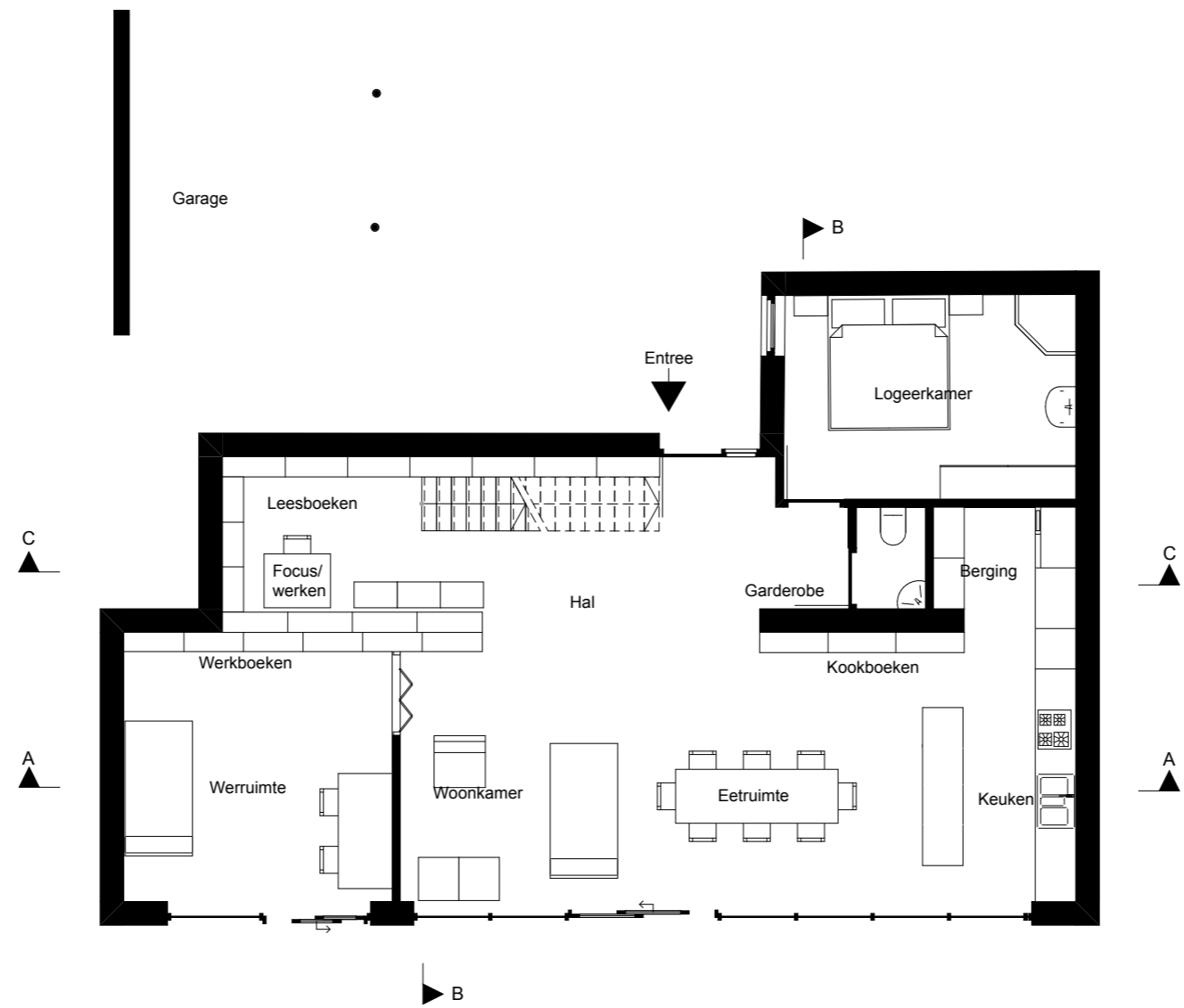

Begnagrond

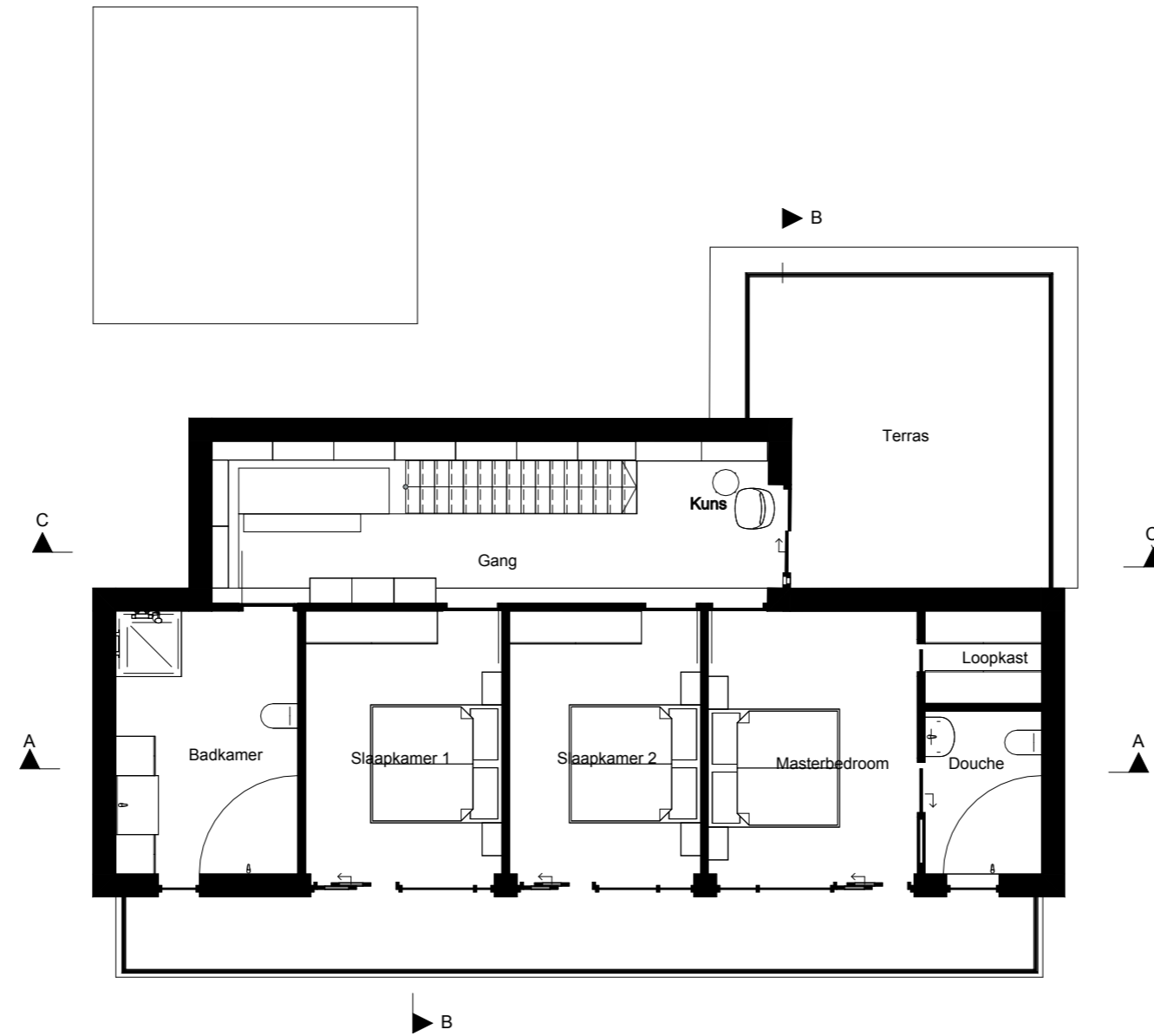

1e Verdieping

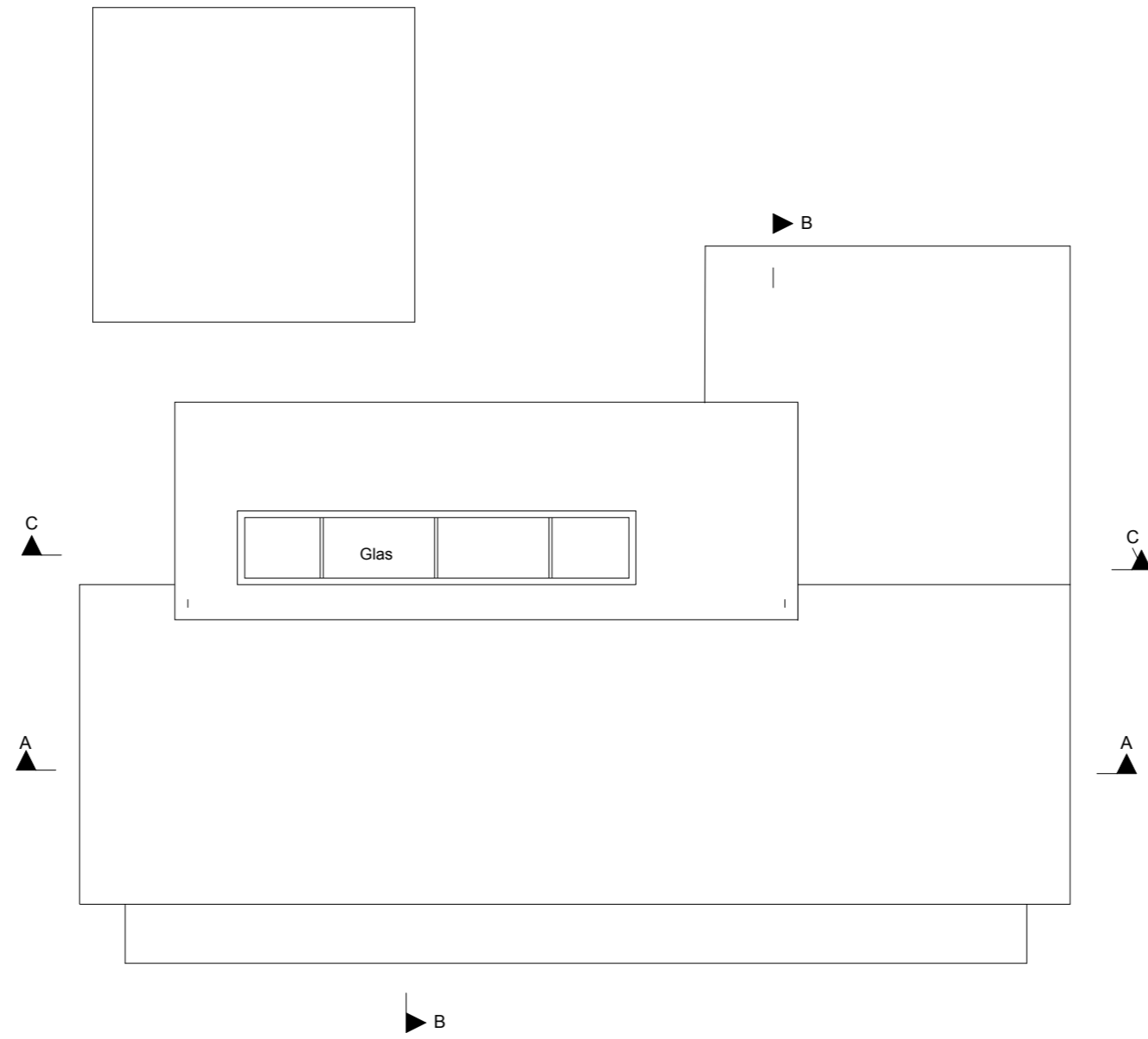

Dakaanzicht

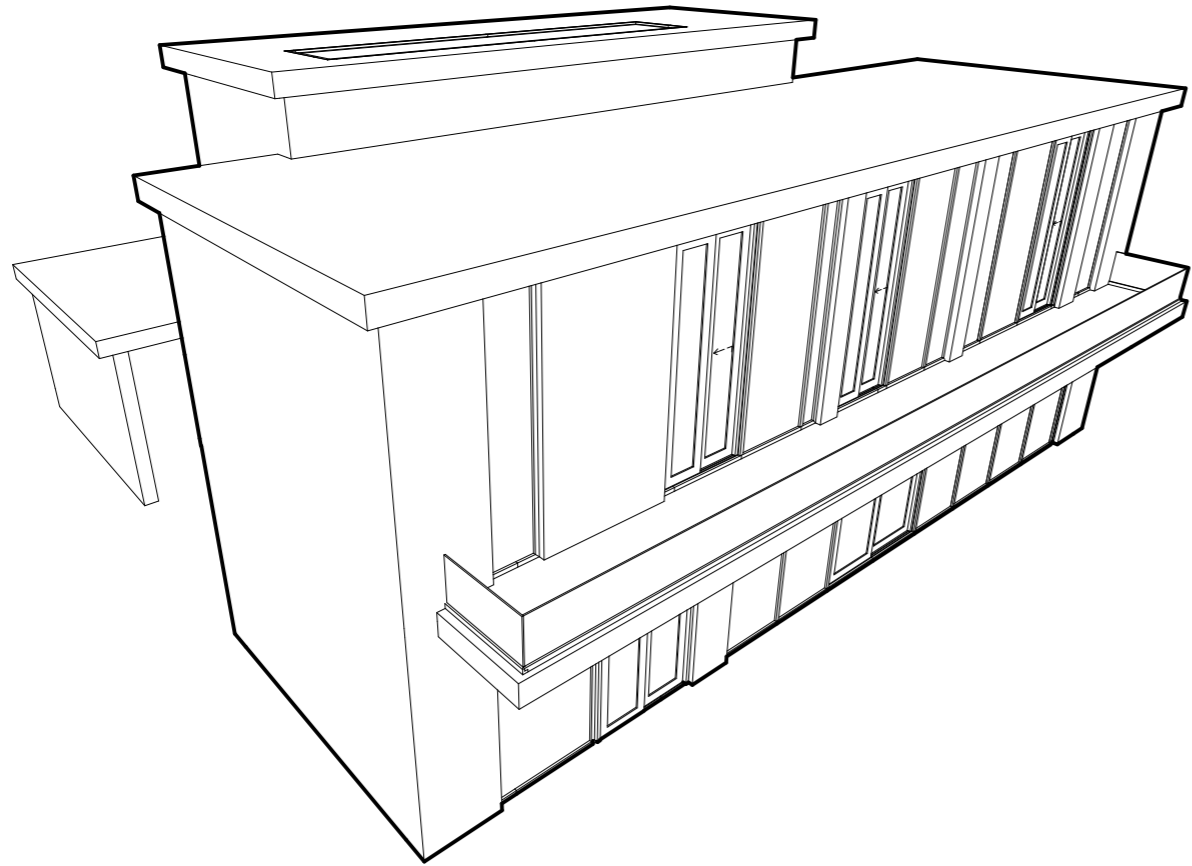

Isometrie

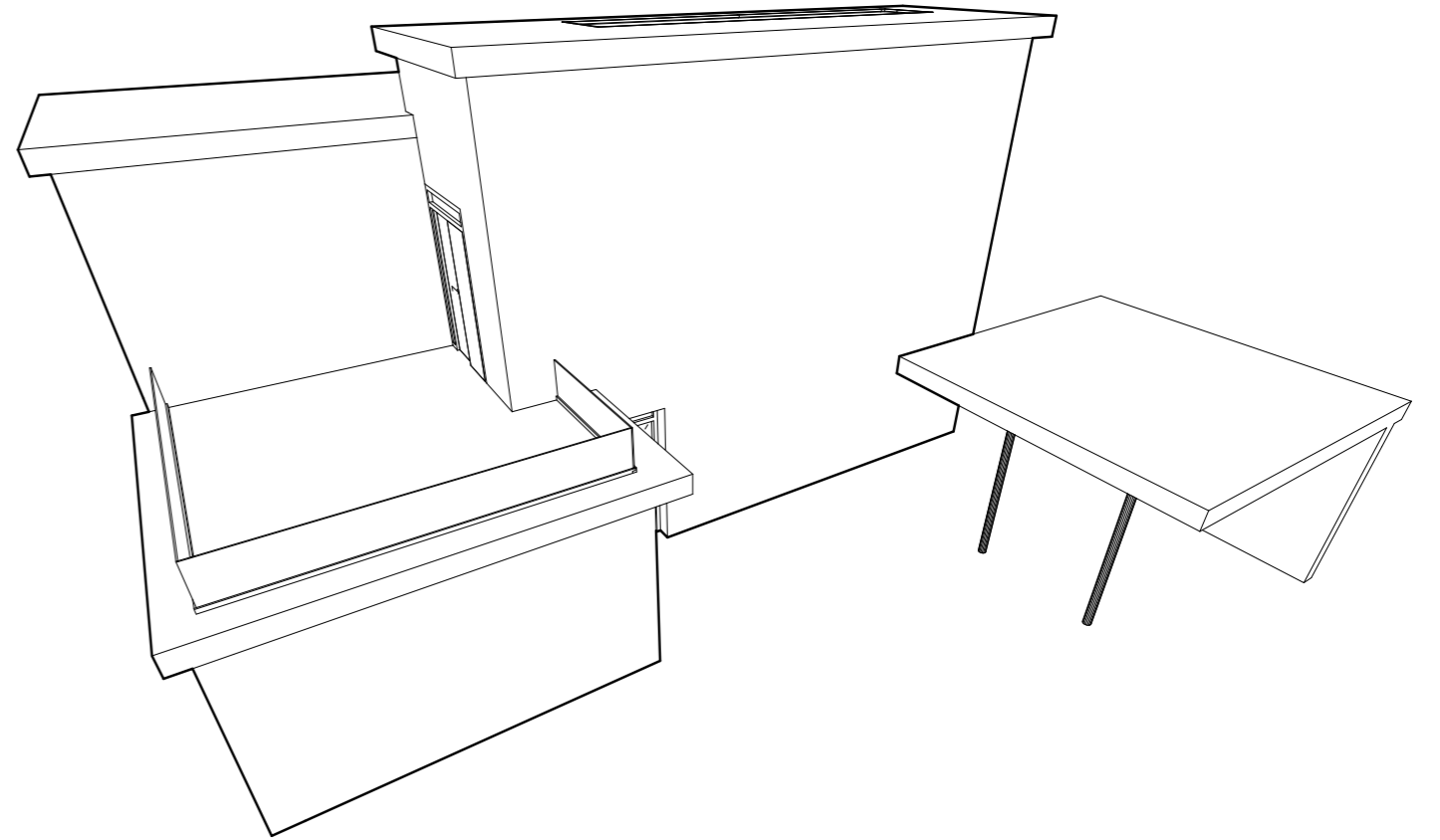

Isometrie

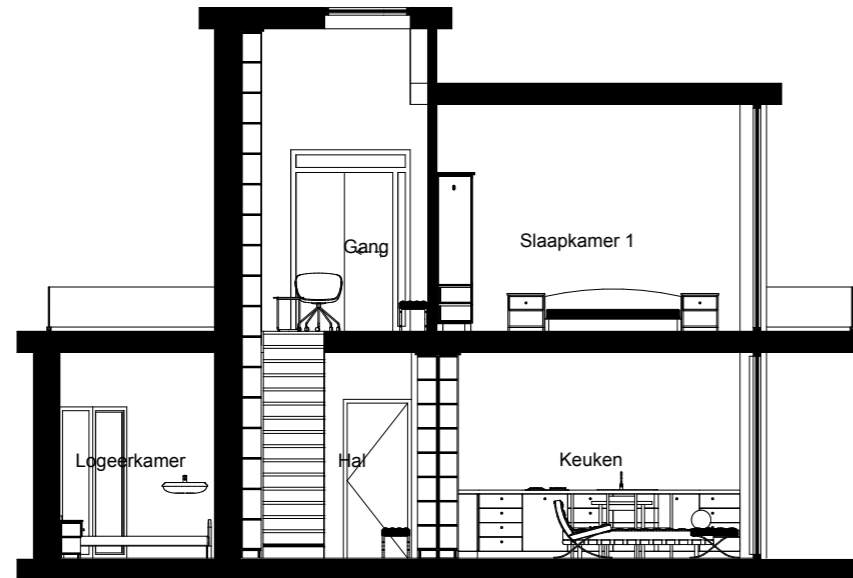

Doorsnede A-A

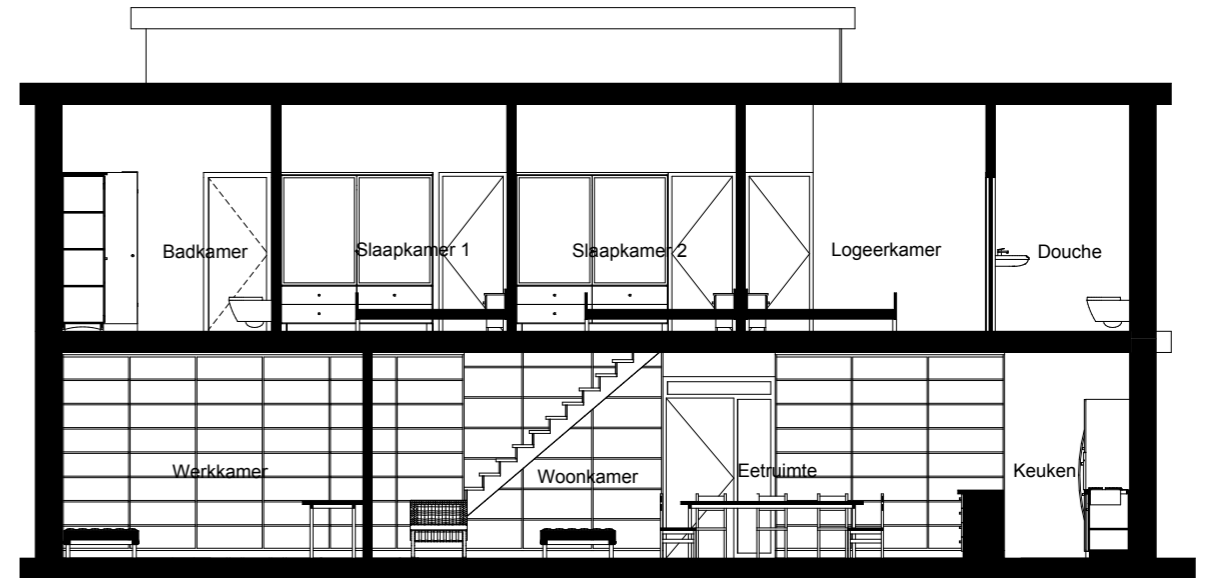

Doorsnede B-B

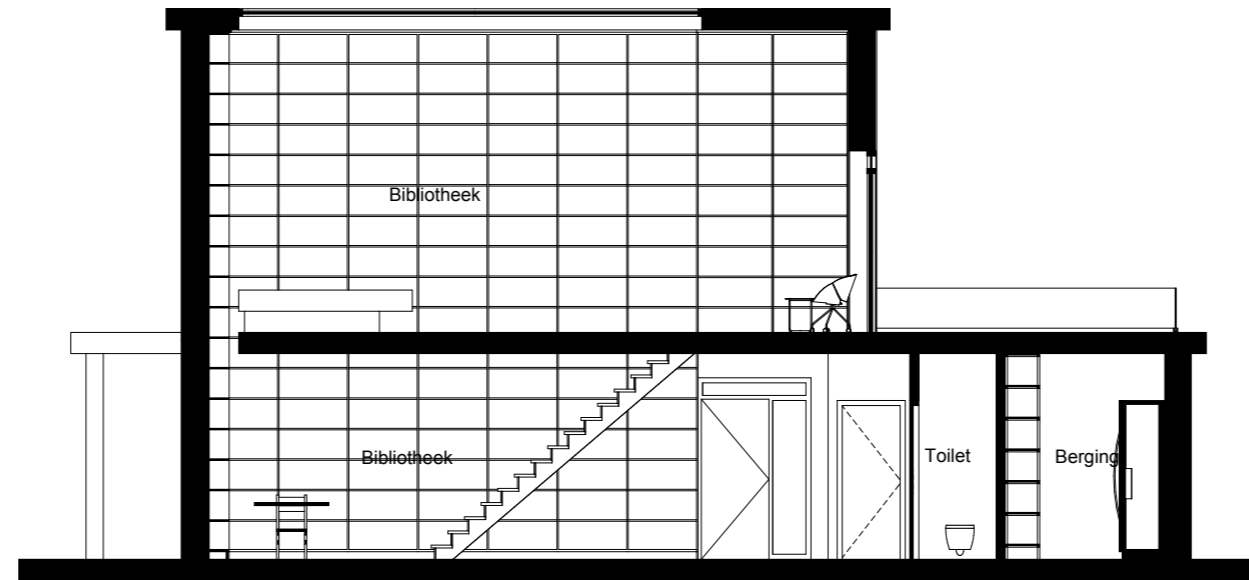

Doorsnede C-C

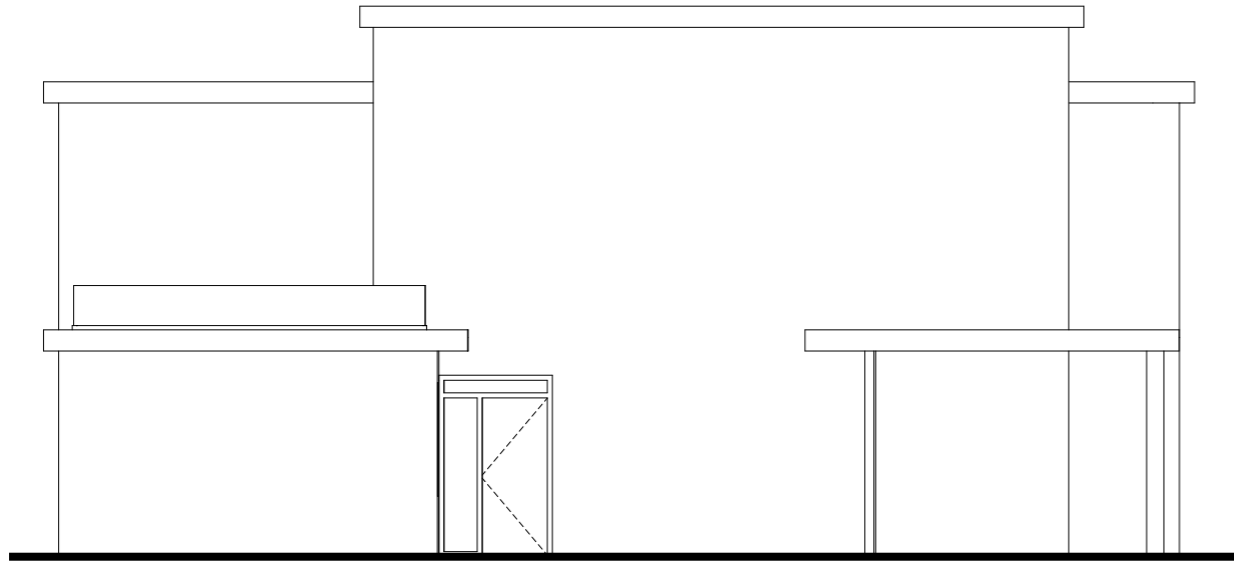

Voorgevel

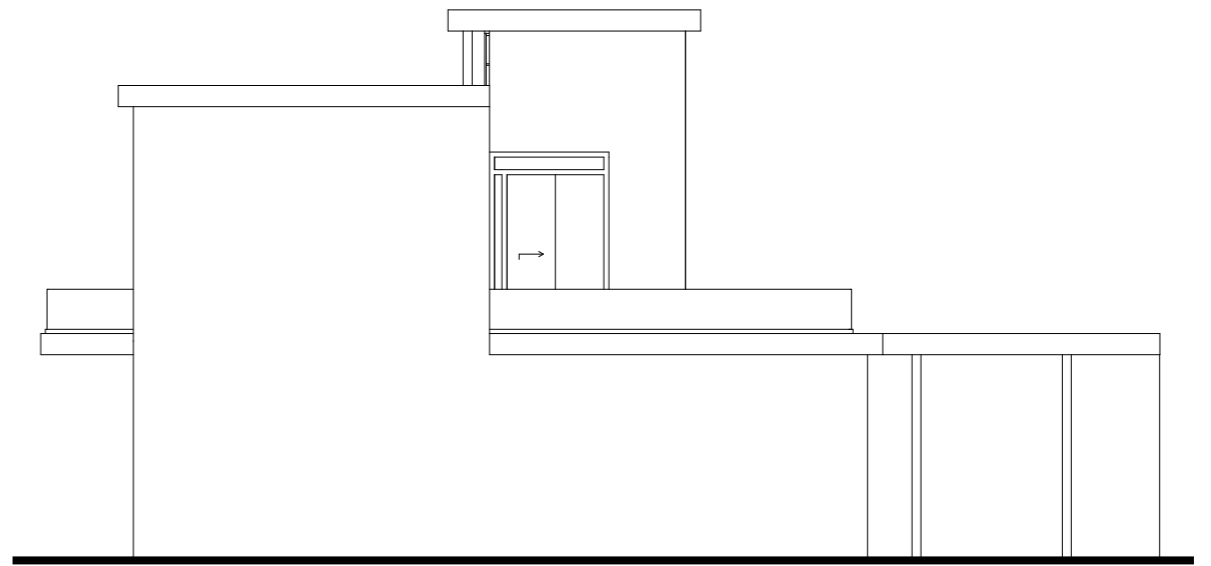

Rechter zijgevel



Voorgevel

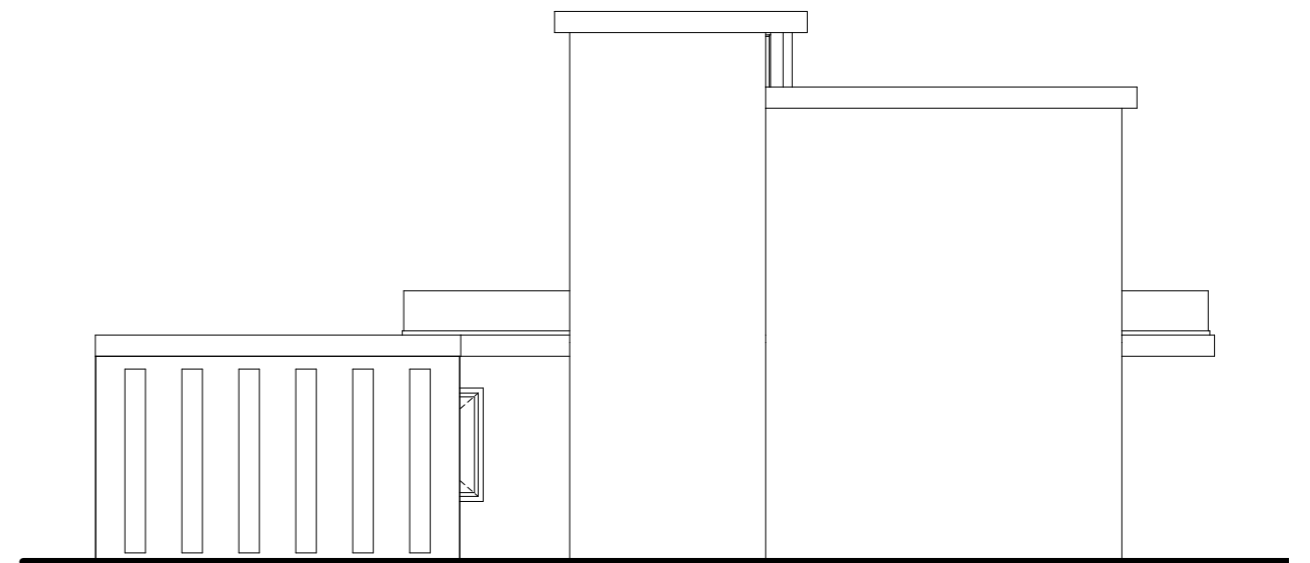

Rechter zijgevel

HUIS V

Het huis heeft geen gang, wel deuren en trappen. Alle ruimten grenzen aan elkaar.

Concept: Het geval (de kwestie) van de trap.
(The matter of stairs)

Uitgangspunten:

- 1- Trap
- 2- Zichtlijnen
3. Repetitie

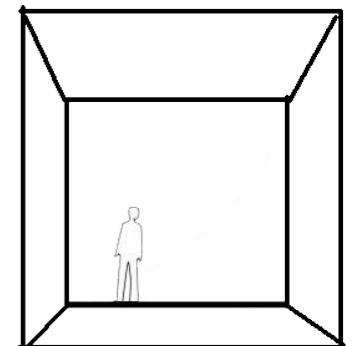
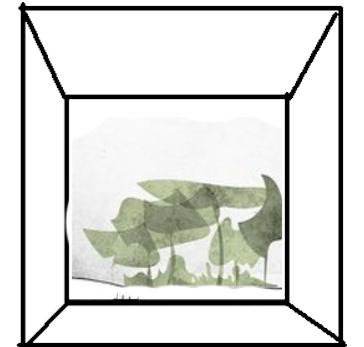
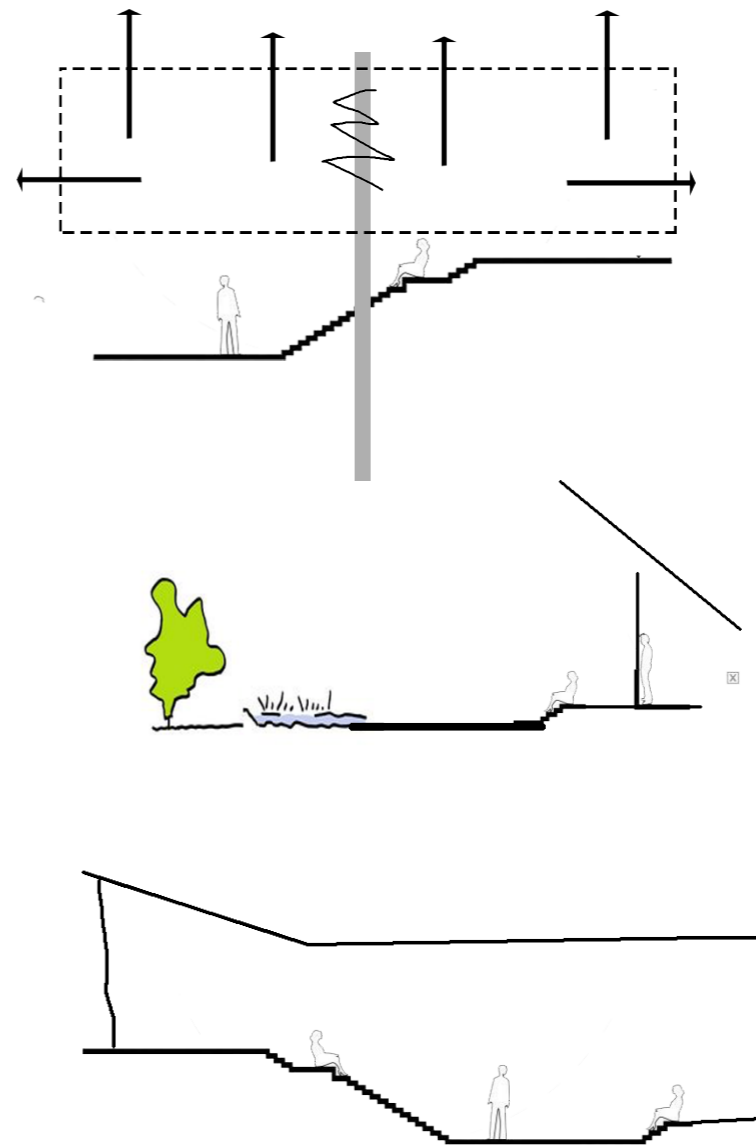

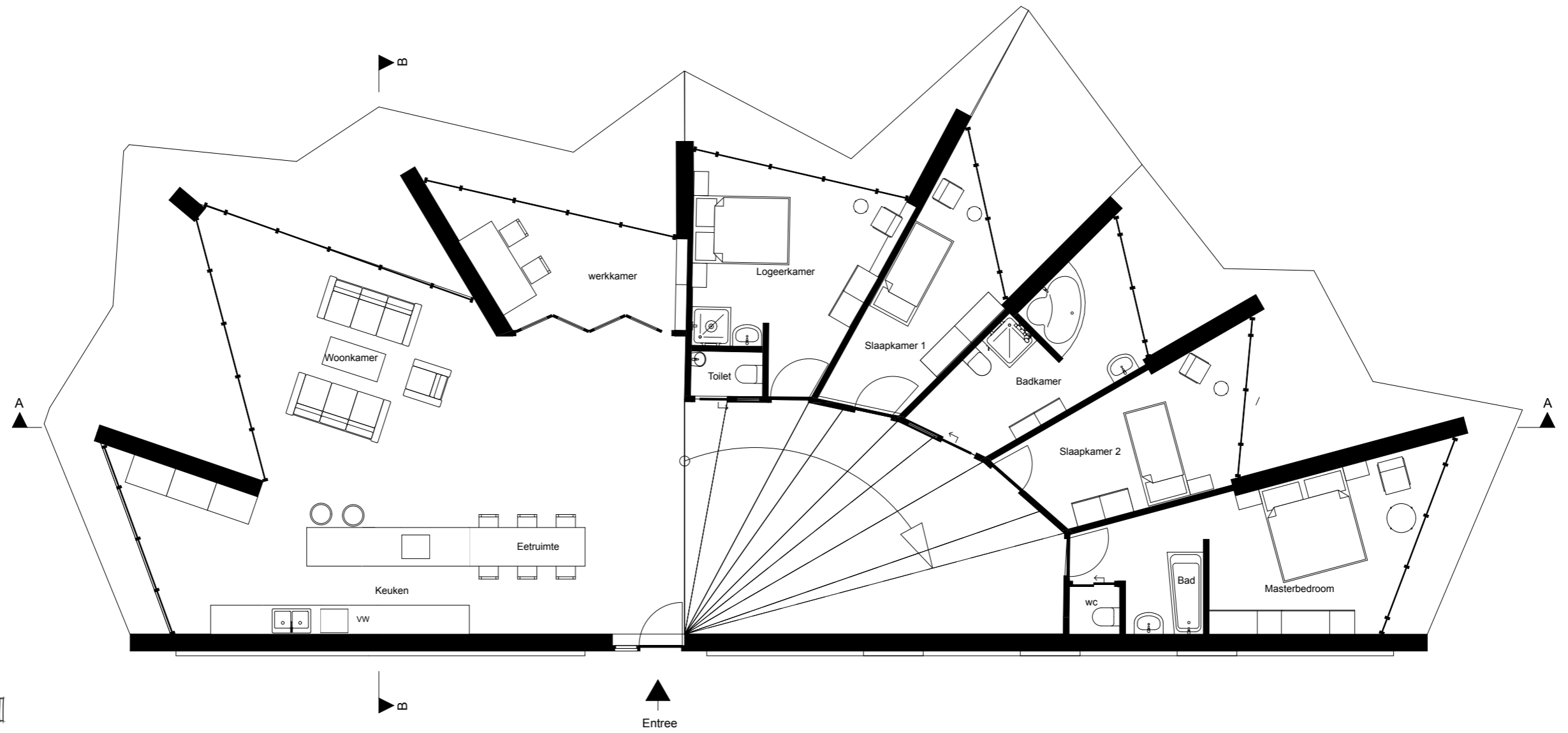

Rechter zijgevel

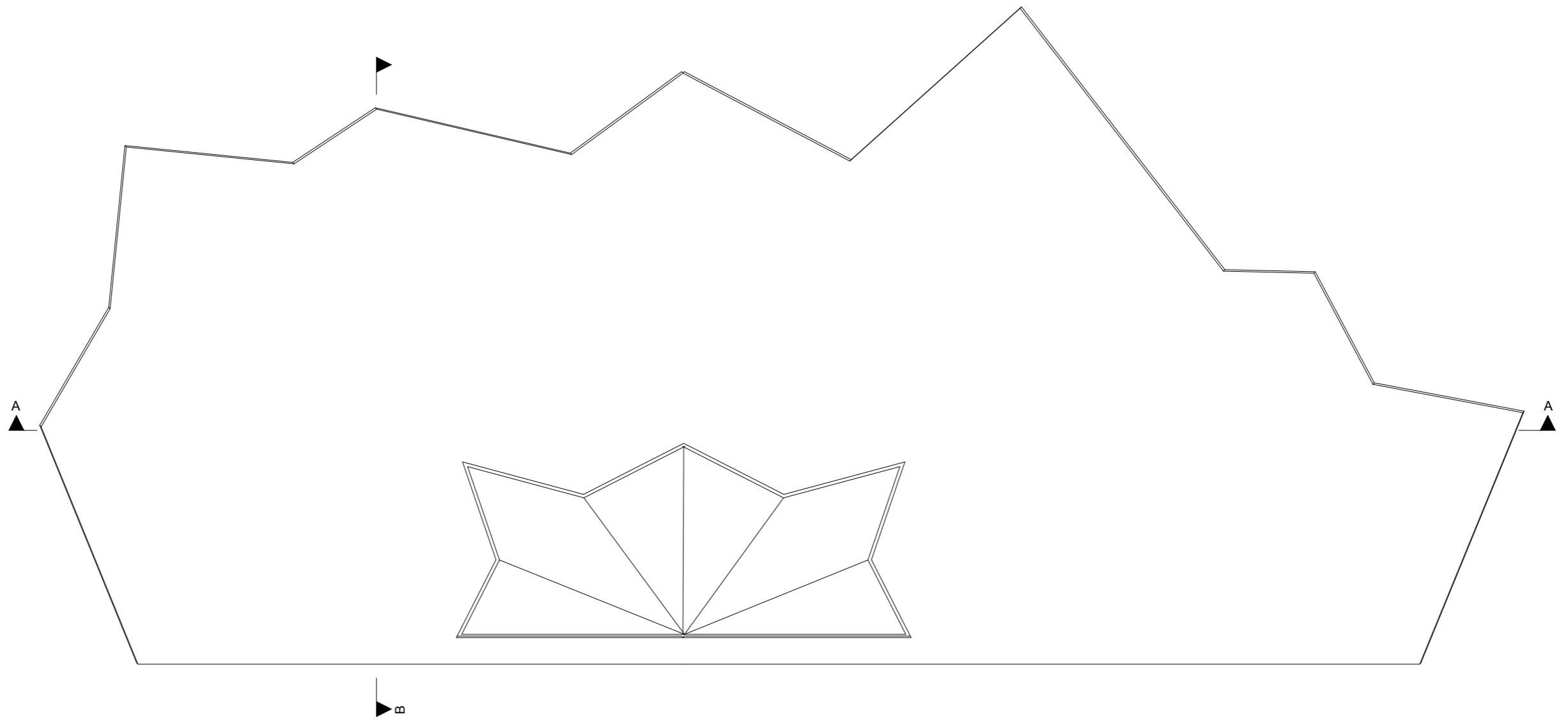

Dakaanzicht

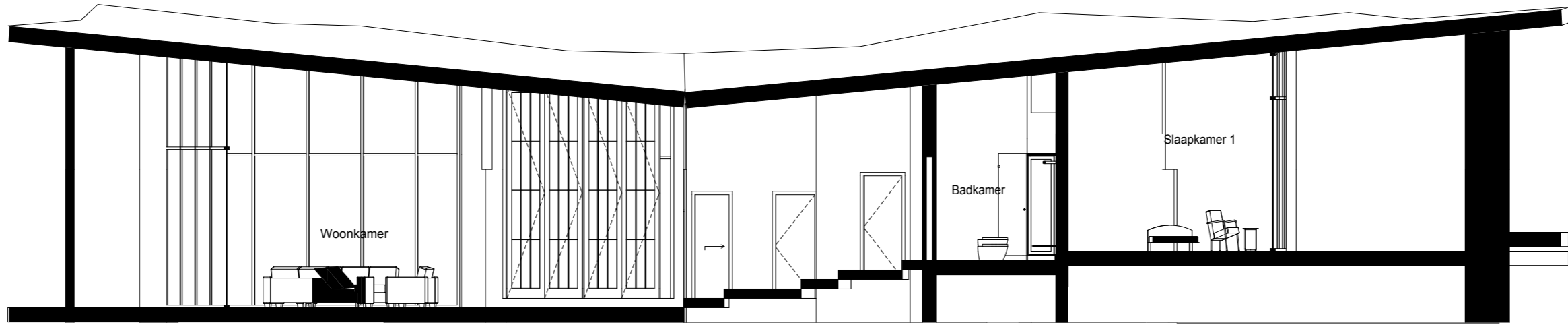

Doorsnede A-A



Doorsnede B-B

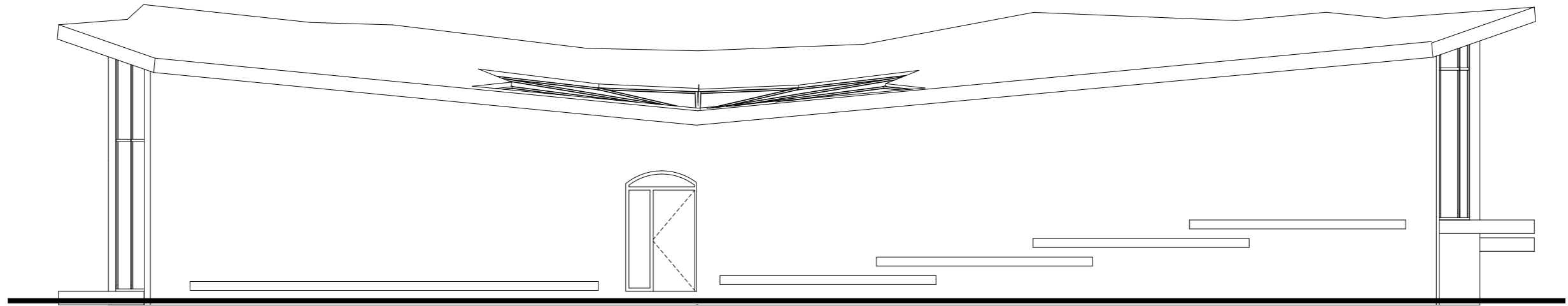

Voorgevel

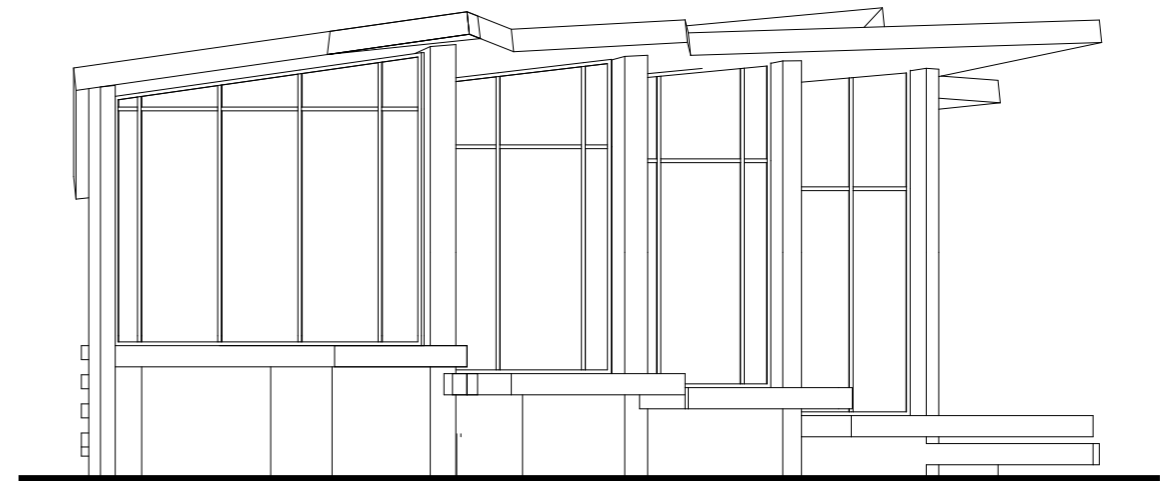

Rechter zijgevel

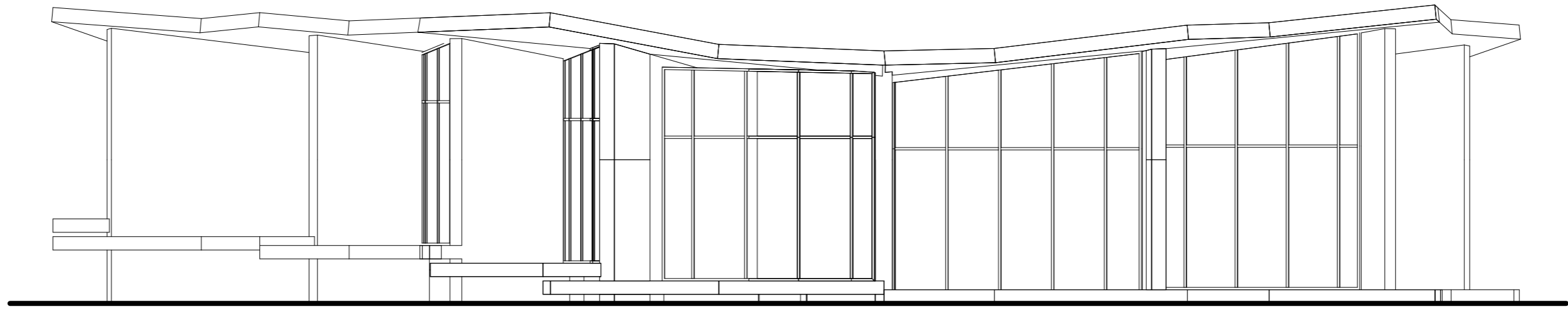

Achtergevel

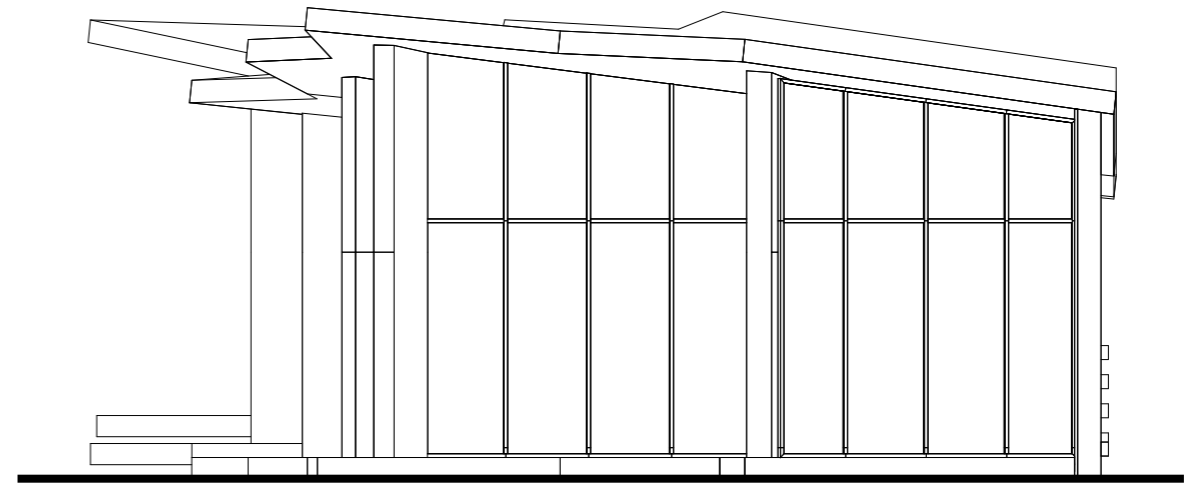

Linker zijgevel

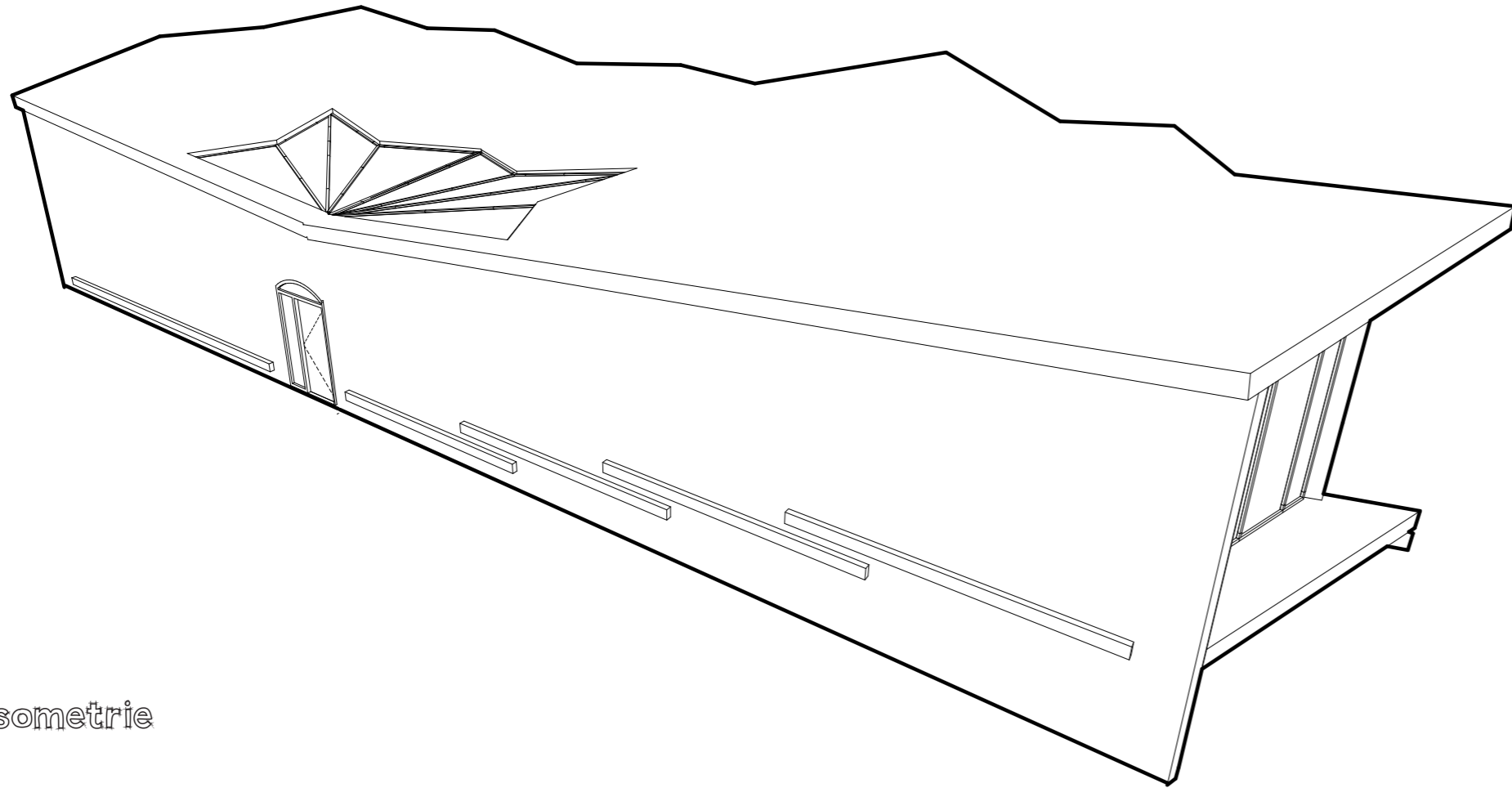

Isometrie

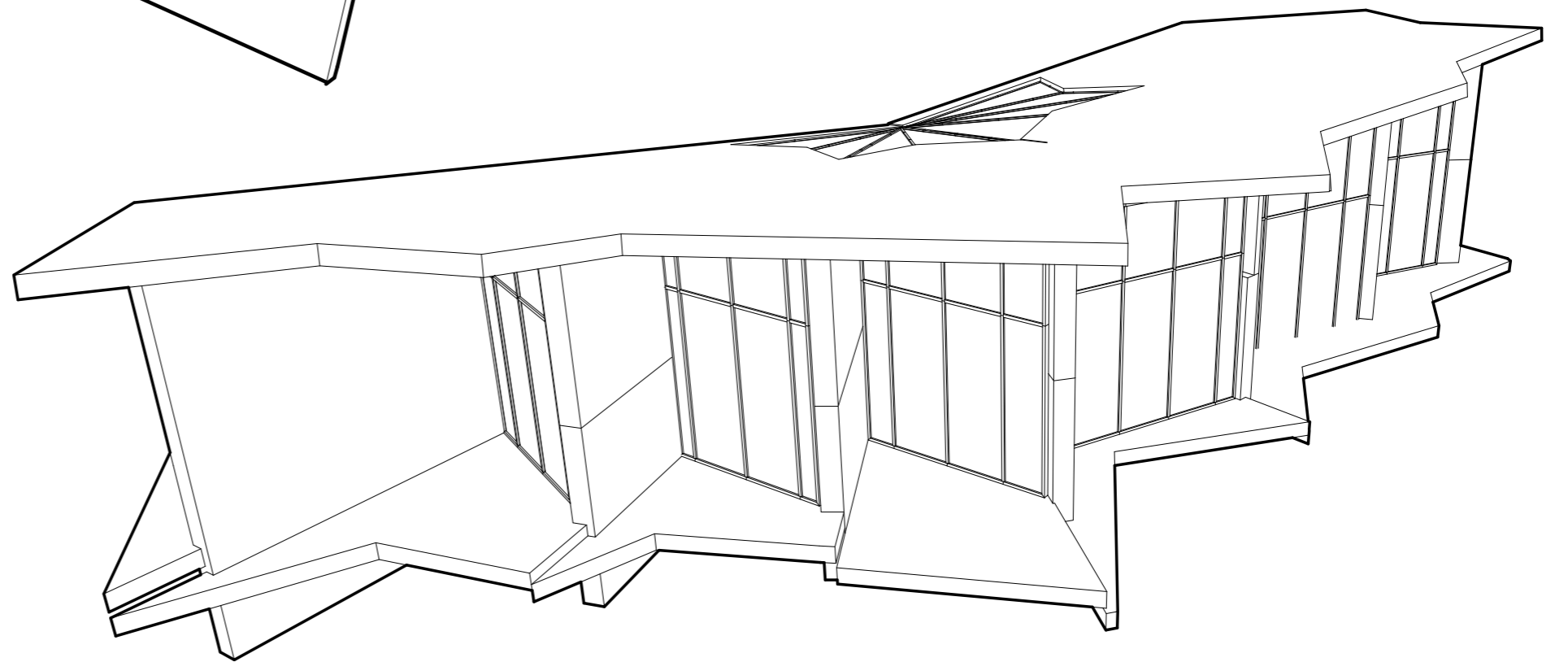

Rechter zijgevel

HUIS VI
Storyboard.

BLAUWE WERELED ZWEAMEN

Uitgangspunten:

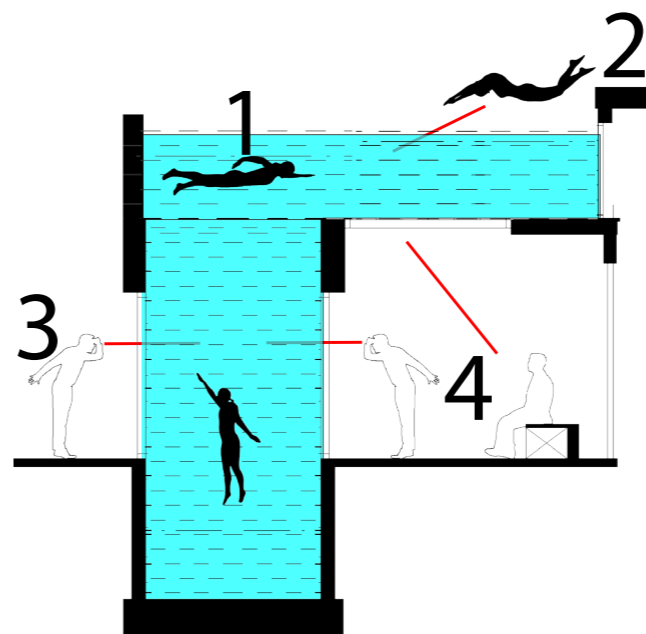

4 ASPECTEN

- 1- In het - Zwembad
- 2- Onder - Zwembad
- 3- Naast / Voor - Zwembad
- 4- Boven - Zwembad

