

07. ACCENTEN

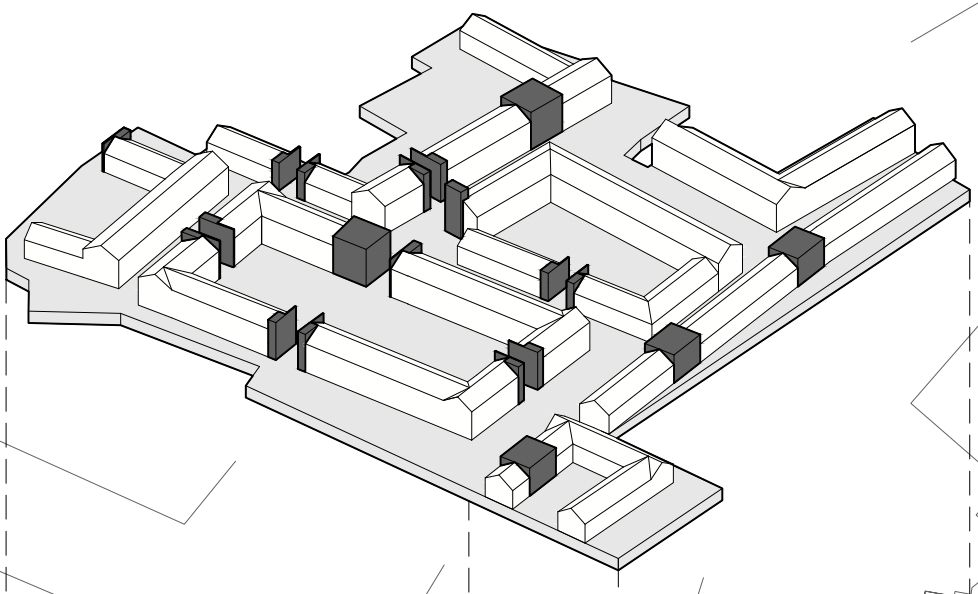

06. PUBLIEK / COLLECTIEF

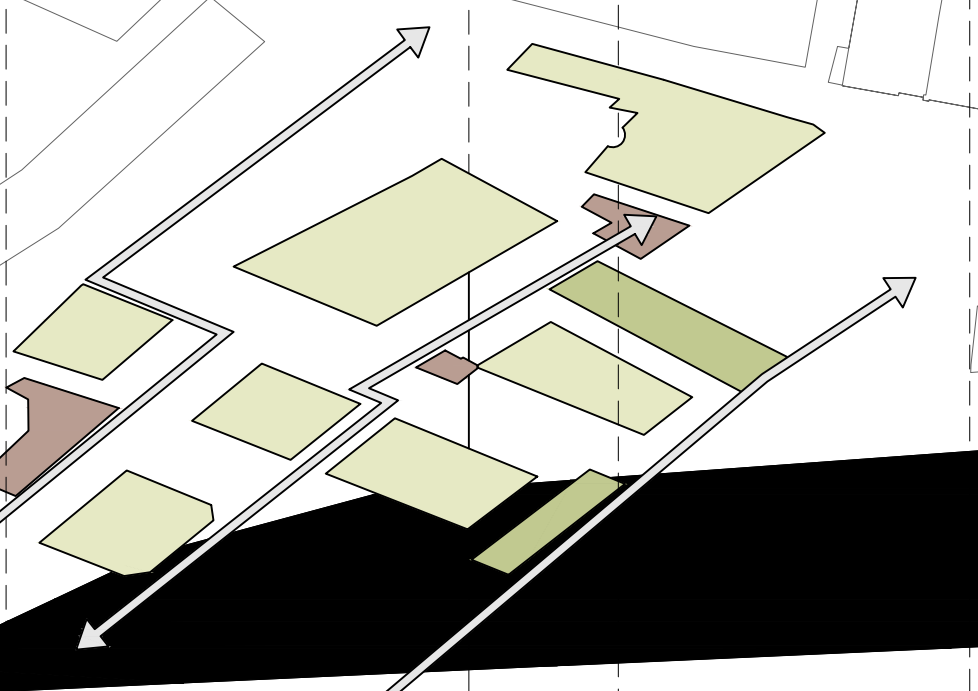

05. STRUCTUUR

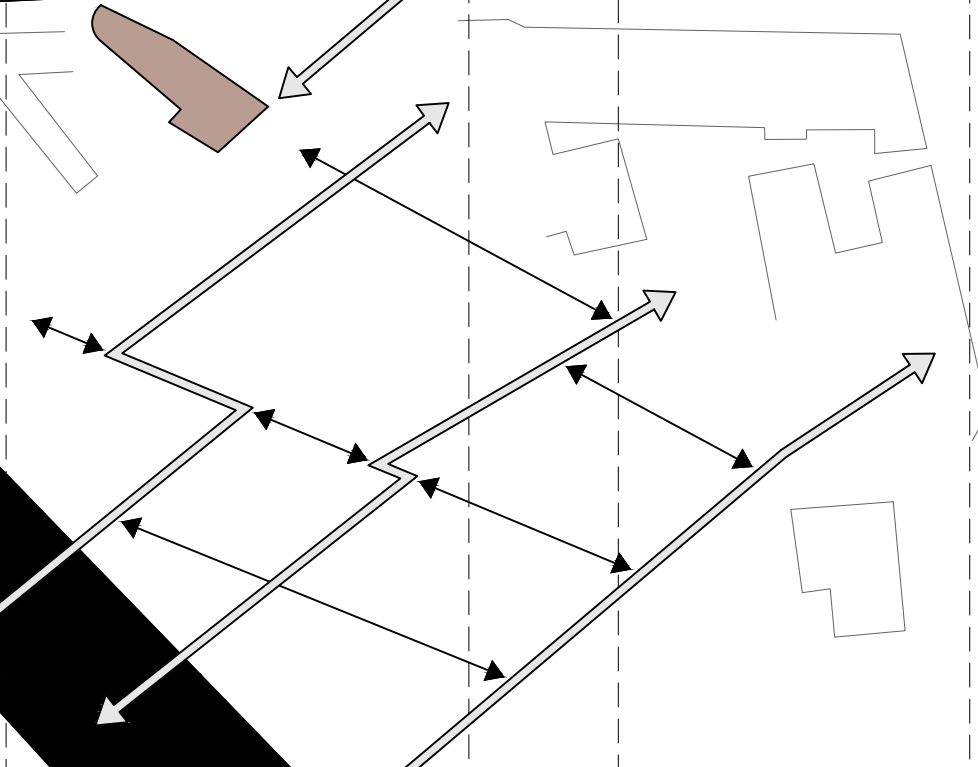

04. STEDELIJKE LEEFOMGEVING

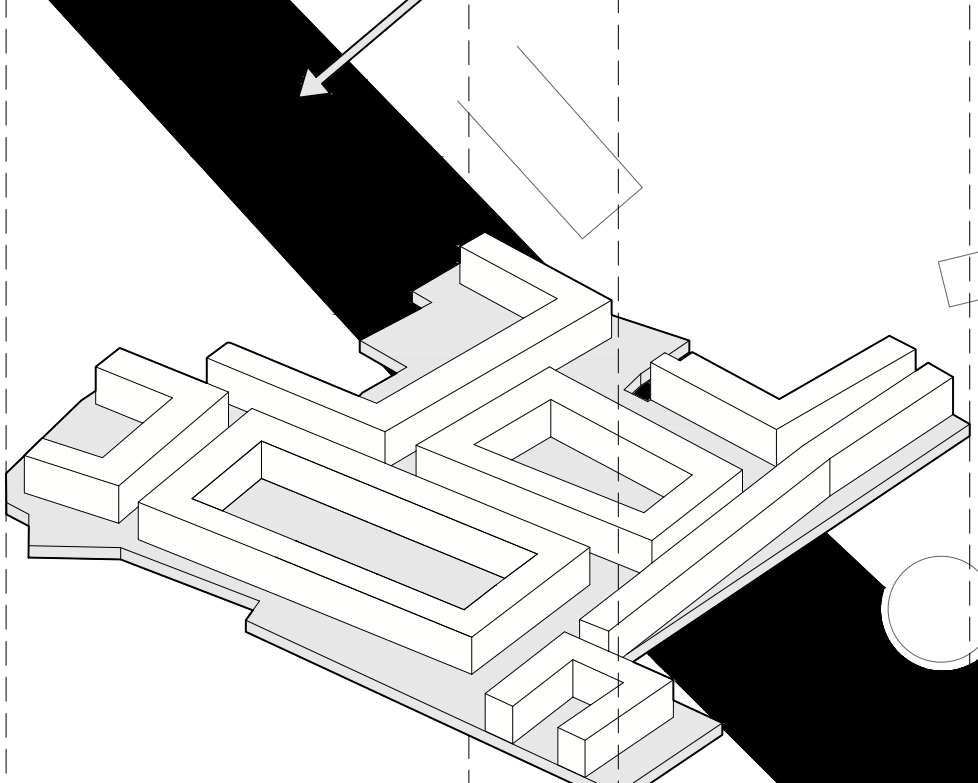

03. VELDEN

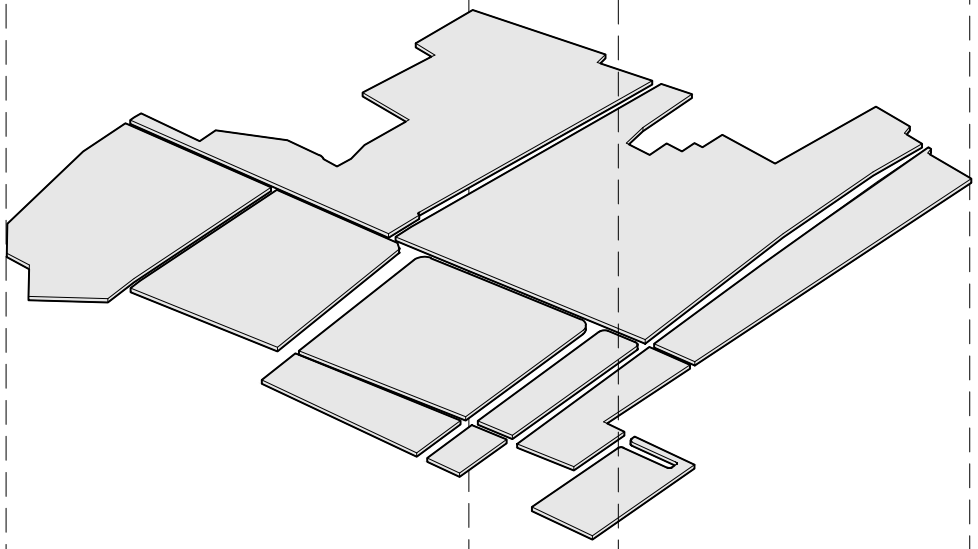

02. HISTORISCHE IDENTITEIT

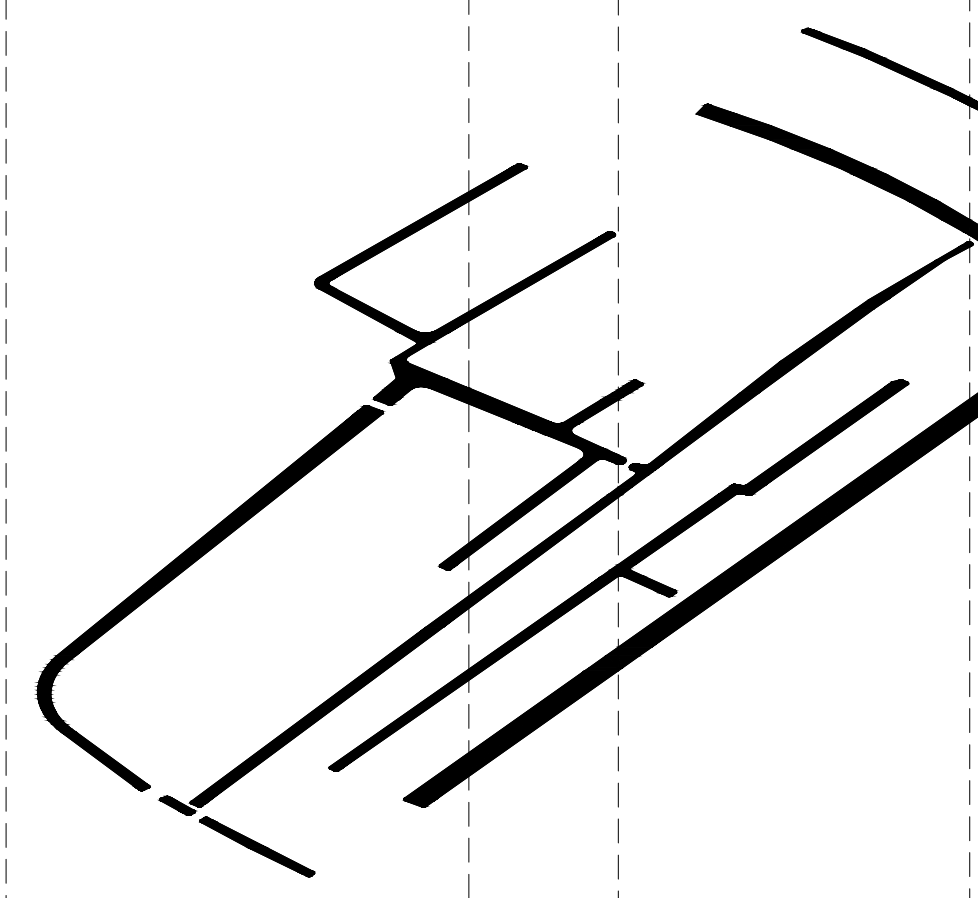

01. CONTOUR

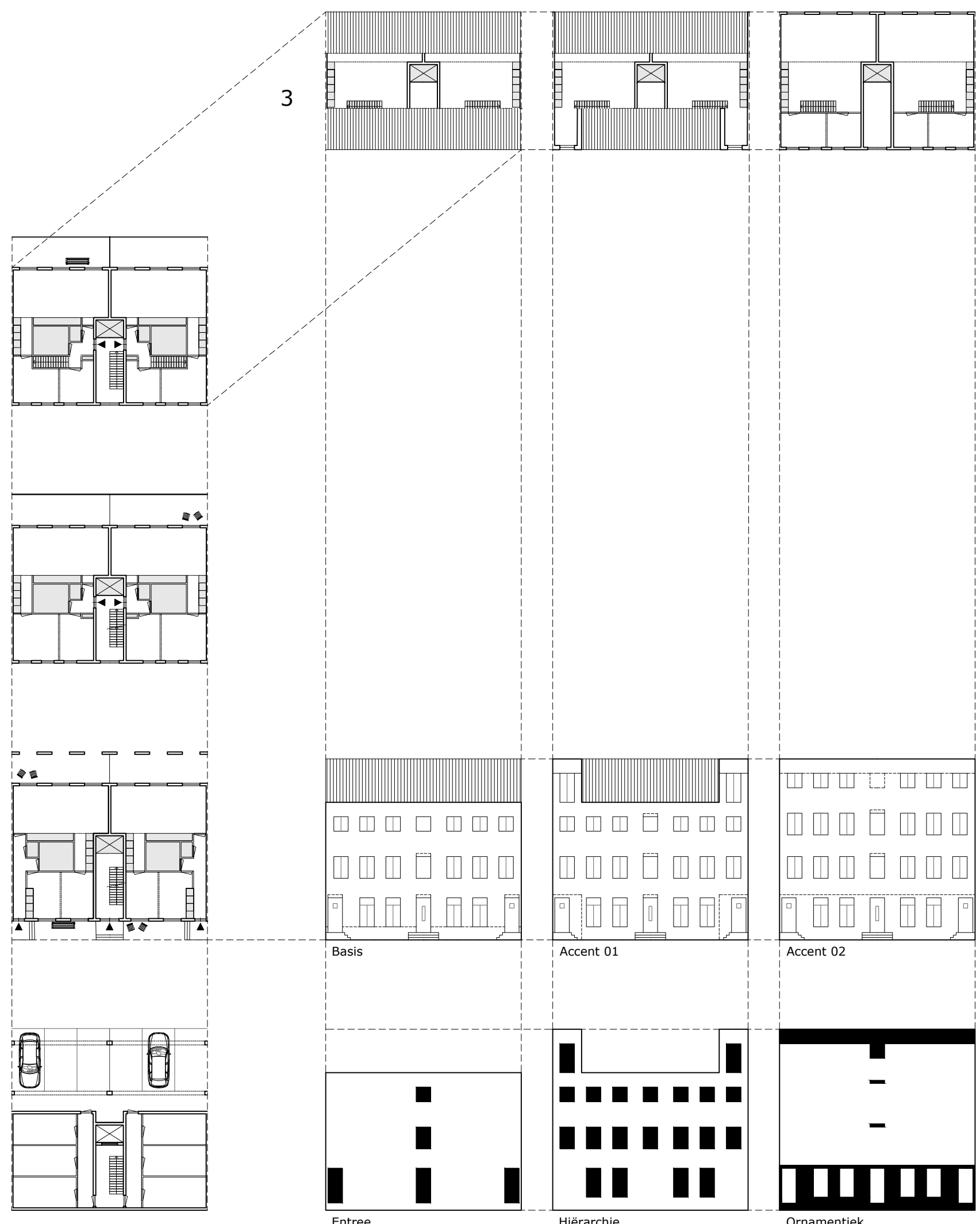
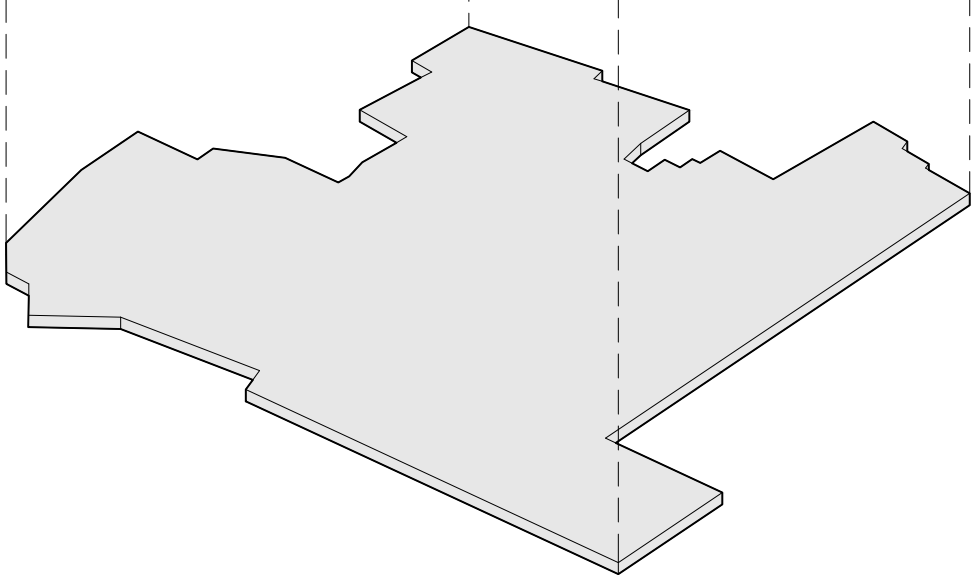

Woningtype A, Portiek-woning

Grondgebonden: Straatontsluiting, benedenwoning
Niet grondgebonden: Portiek, portiekrijwoning
Oppervlakte: Basis 85,8 m²
Accent 01 125,8 m²
Accent 02 171,6 m²

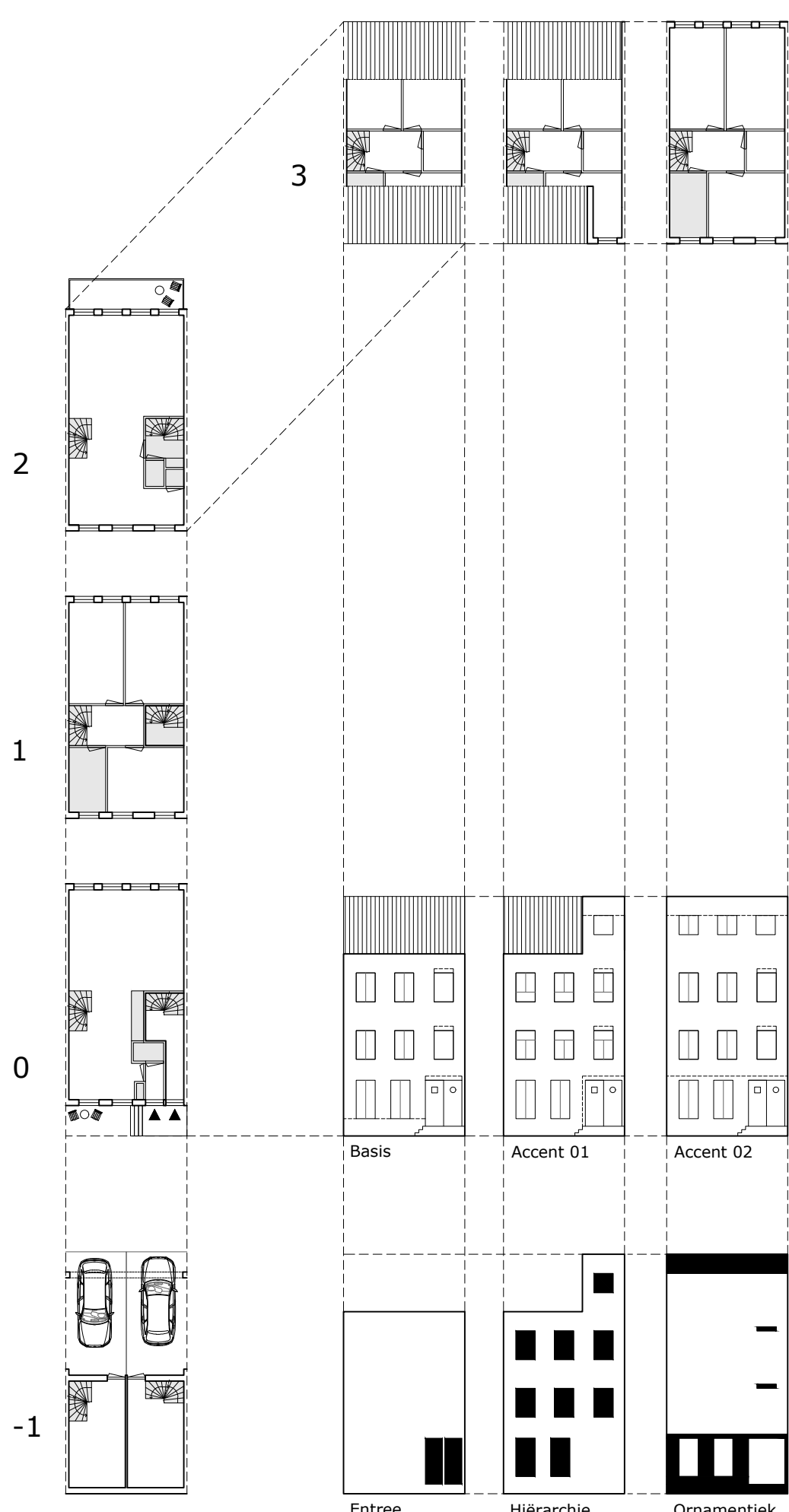

Woningtype B, Beneden bovenwoning

Grondgebonden: Straatontsluiting, benedenwoning
Niet grondgebonden: Straatontsluiting, bovenwoning
Oppervlakte: Beneden woning 138,2 m²
Boven woning 128,6 m²
Accent 01 148,9 m²
Accent 02 162,8 m²

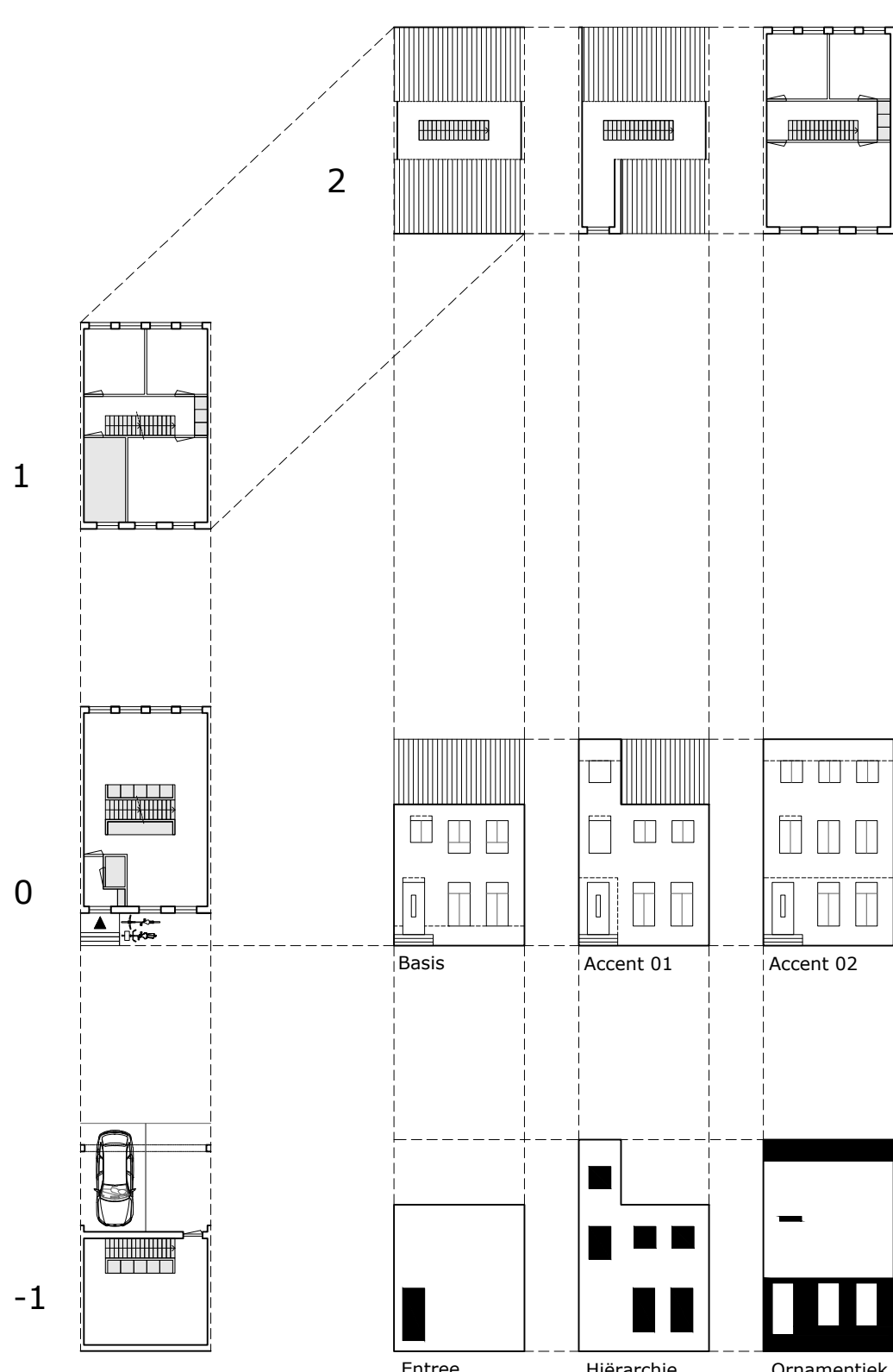

Woningtype C, Eengezinswoning

Grondgebonden: Straatontsluiting, rijwoning
Oppervlakte: Basis 145 m²
Accent 1 167 m²
Accent 2 194 m²

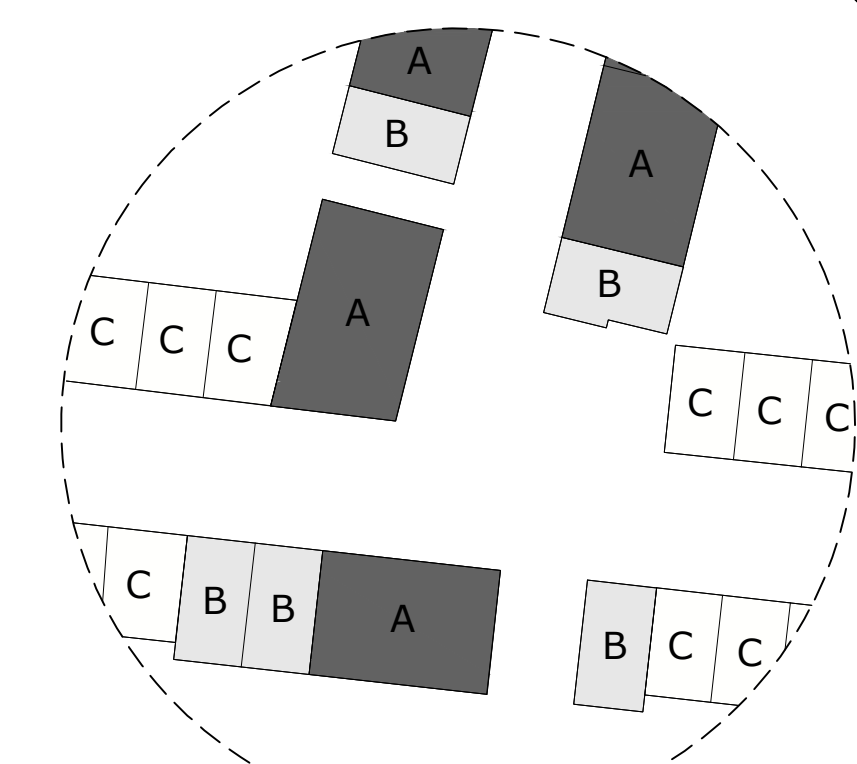

Woningtypes, Planuitwerking

Buurtsamenstelling: Demografische mix
Woningaantal: 376 units

