

Elementair ontwerpen

Meggie Belaert | 20 juni 2018

Opgave 1 | De trap als huis | Kubus woning 10 x 10 x 10 | 1:200

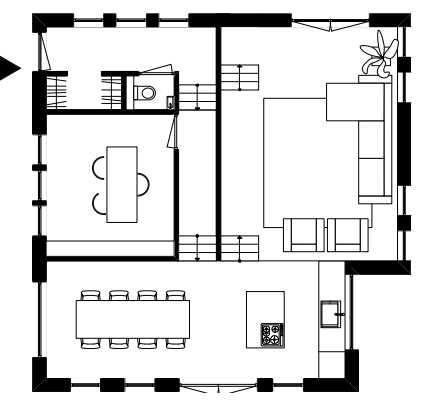

Begane grond

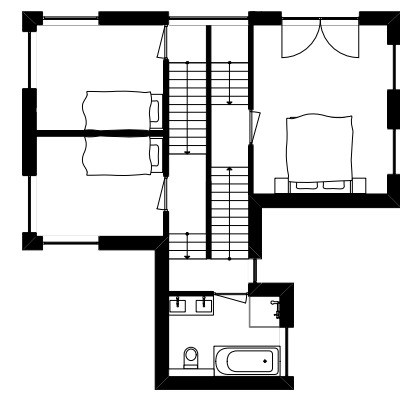

Eerste verdieping

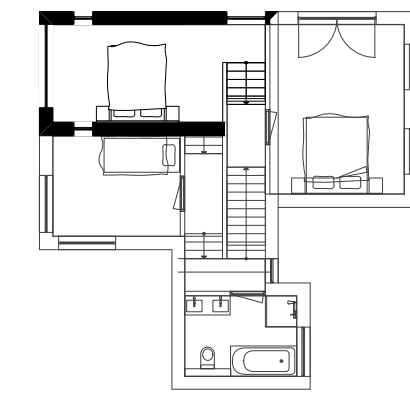

Tweede verdieping

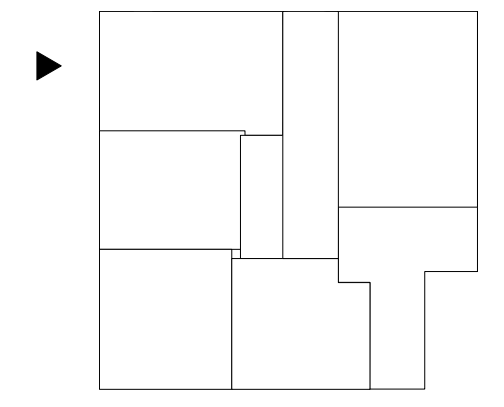

Dakaanzicht

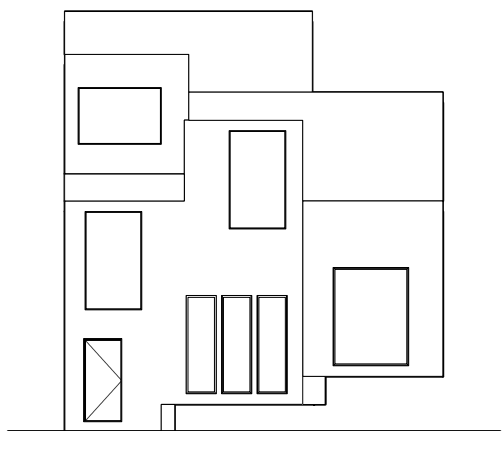

Voorgevel

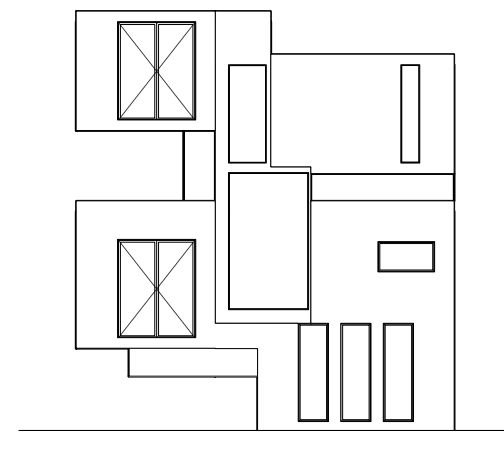

Linkergevel

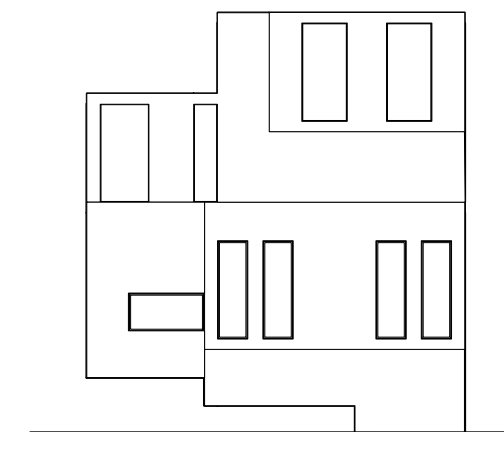

Achtergevel

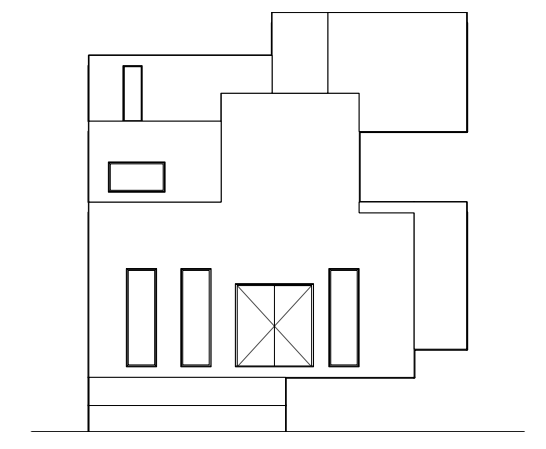

Rechtergevel

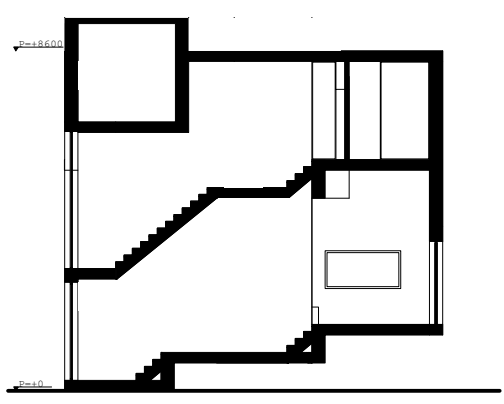

Doorsnede A-A'

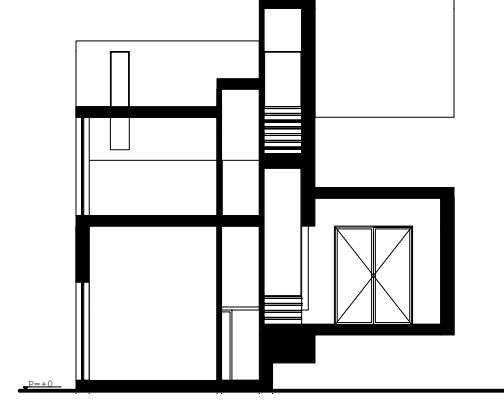

Doorsnede B-B'

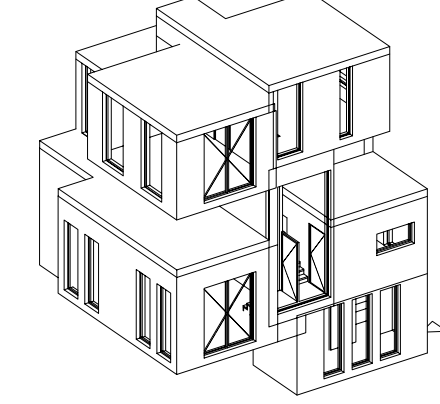

Opgave 2 | De weerspiegeling | Woning zonder openingen, voordeur om 4750mm hoog | 1:200

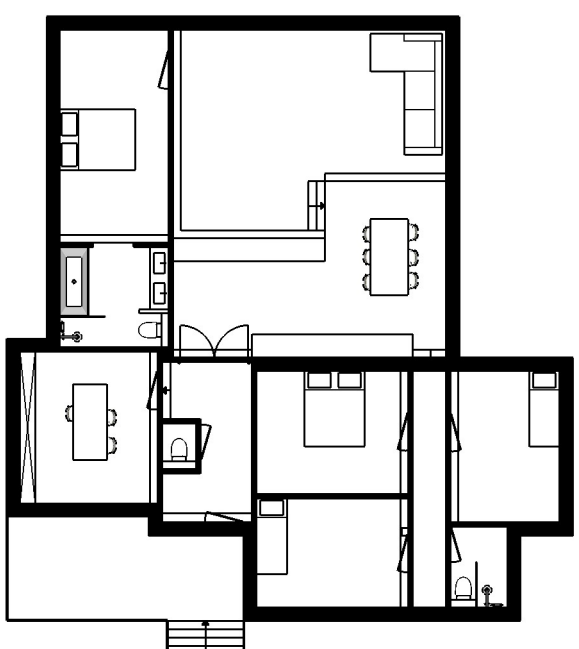

Begane grond

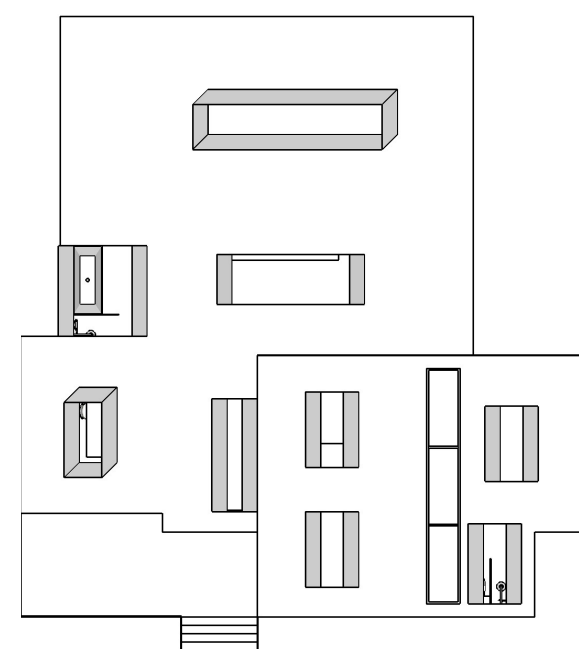

Eerste verdieping

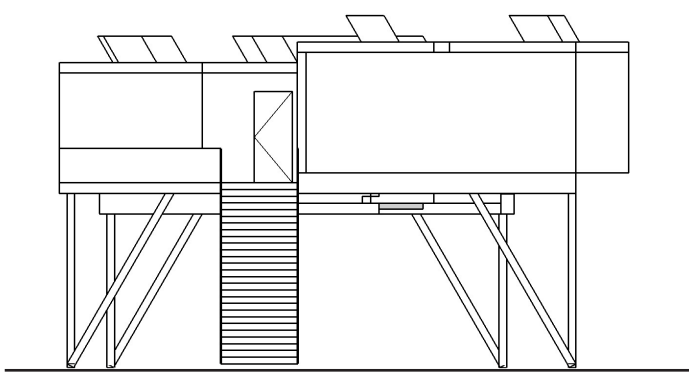

Voorgevel

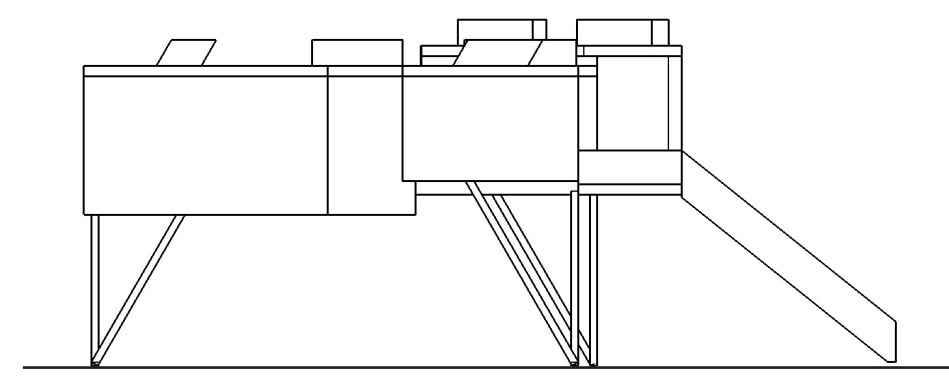

Linkergevel

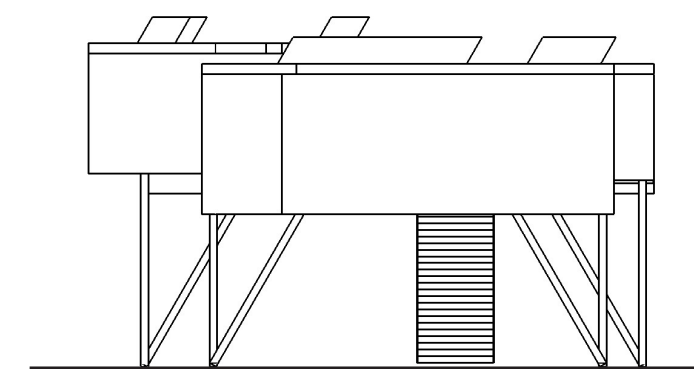

Achtergevel

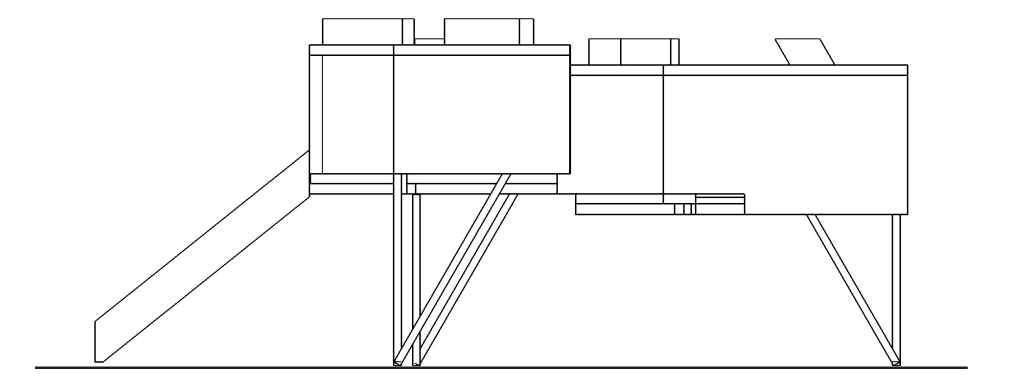

Rechtergevel

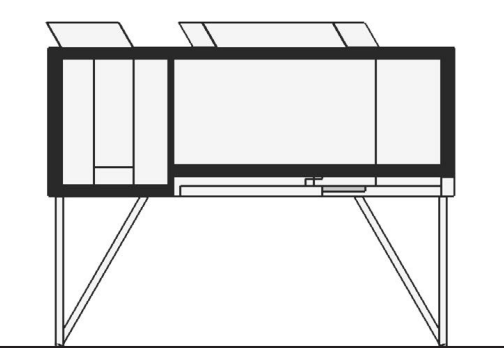

Doorsnede A-A'

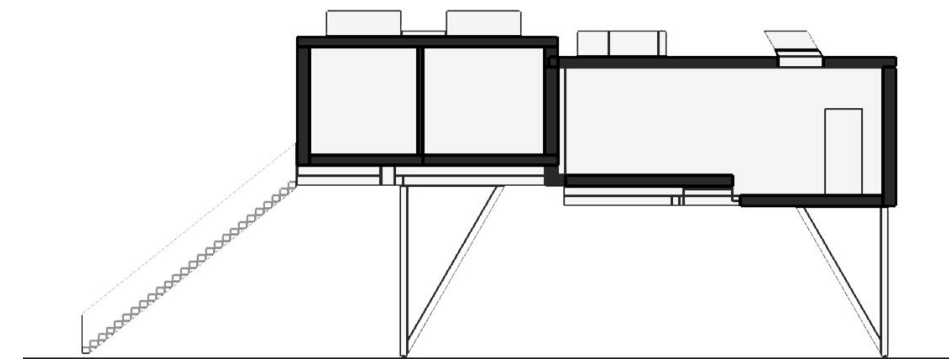

Doorsnede B-B'

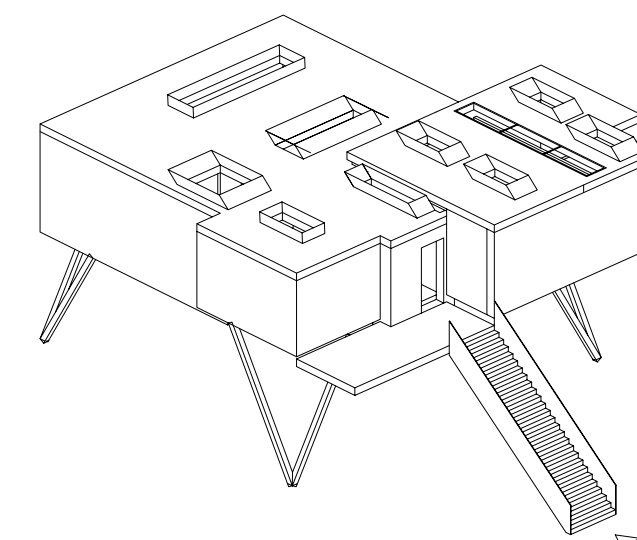

Opgave 3 | Zwembad als gang | Woning met zwembad 1250 mm x 3000 mm | 1:200

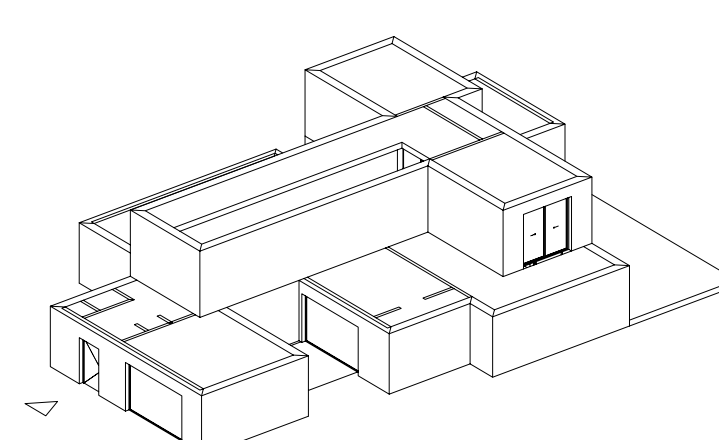
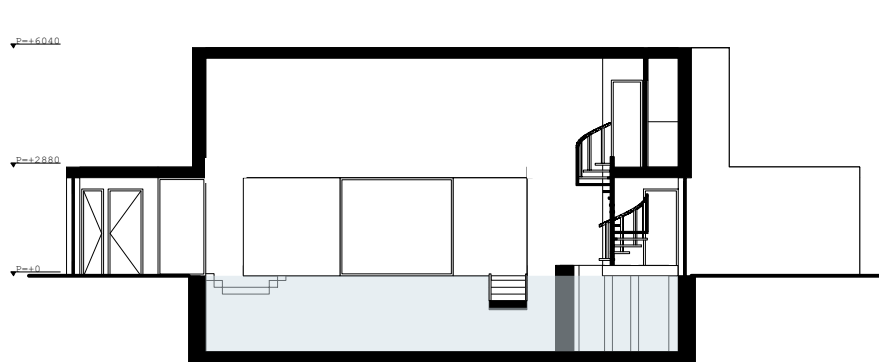
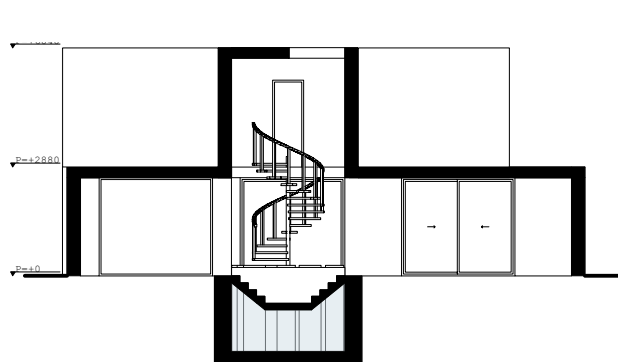
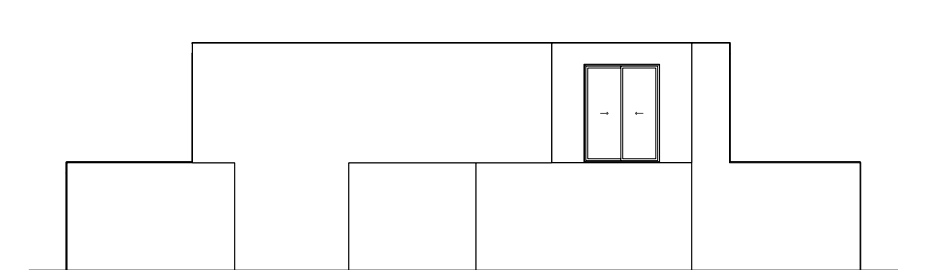
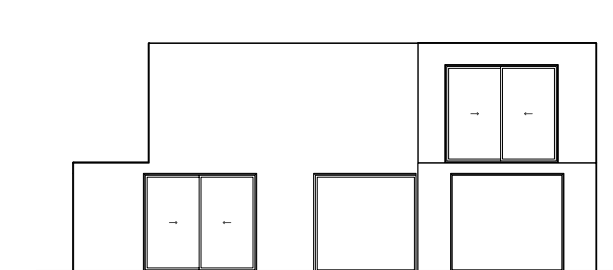
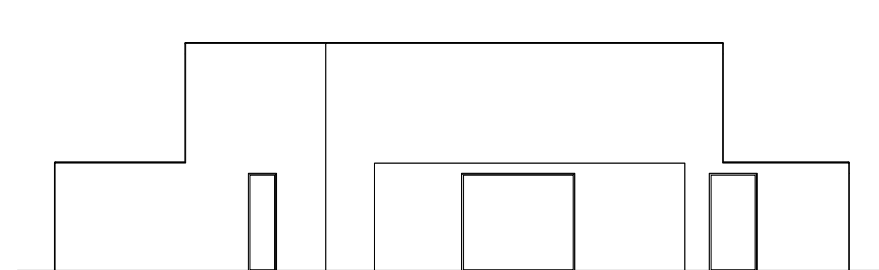
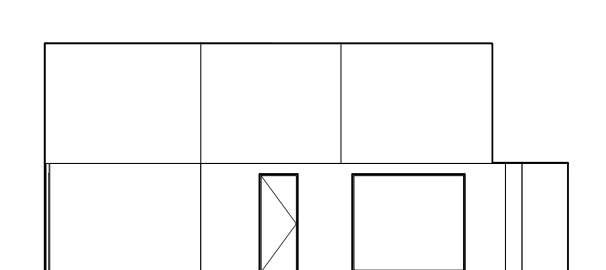
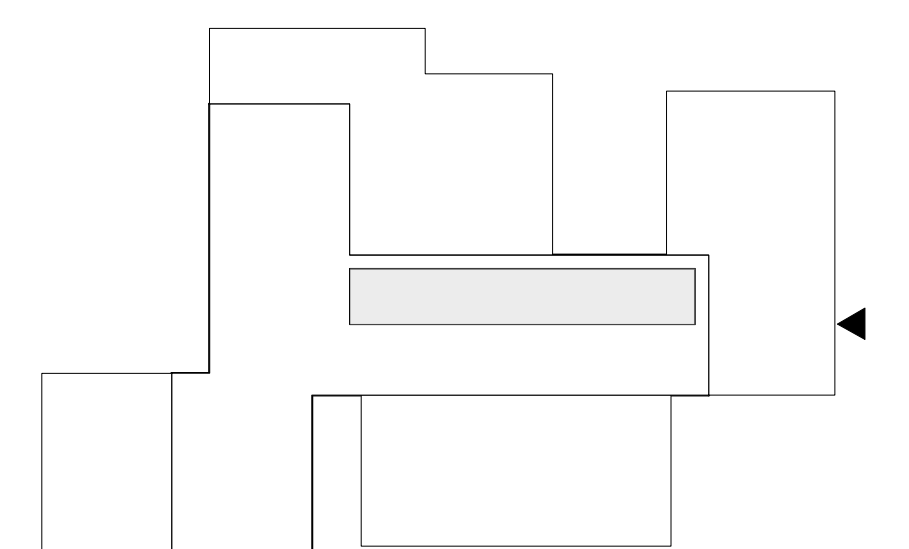
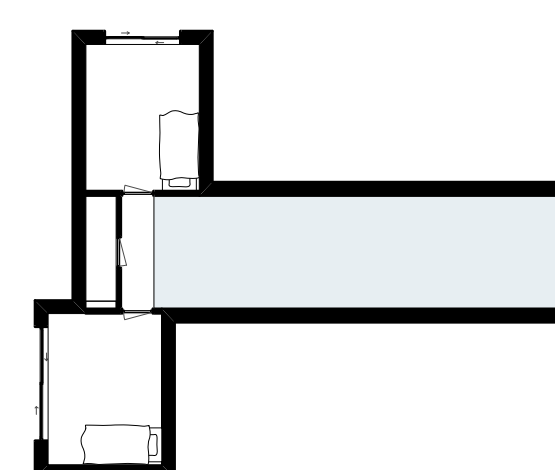
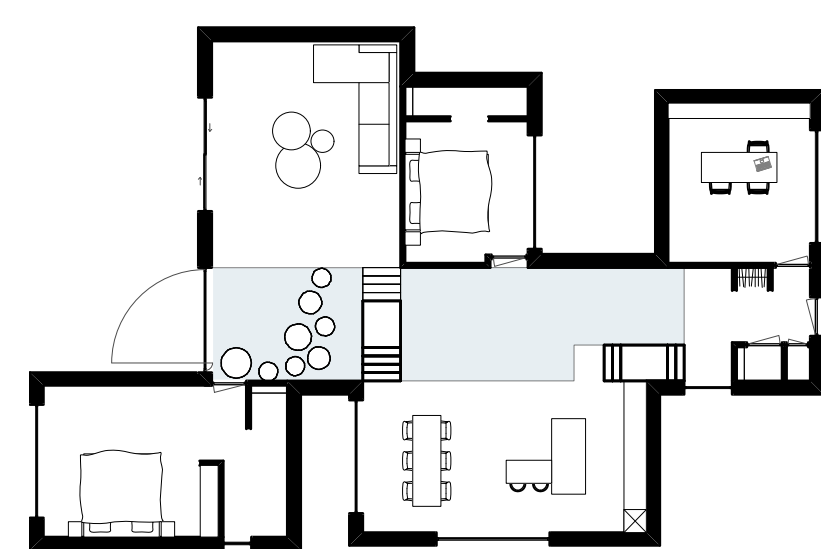

Elementair ontwerpen

Meggie Belaert | 20 juni 2018

Opgave 4 | The active reader | Woning met 250m² boekenplanken | 1:200

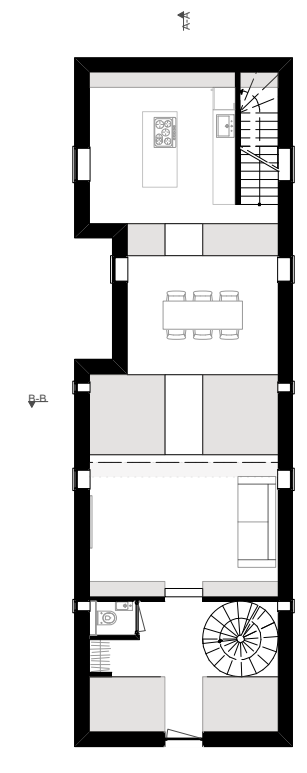

Begane grond

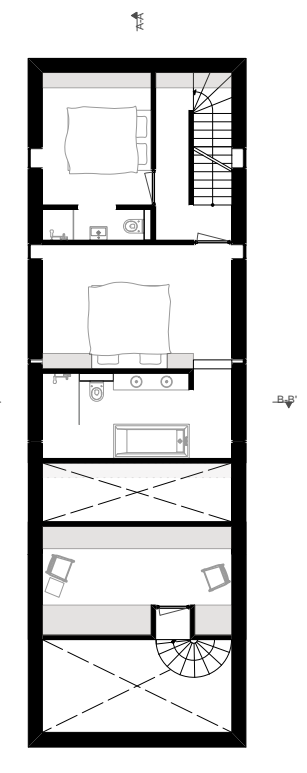

Eerste verdieping

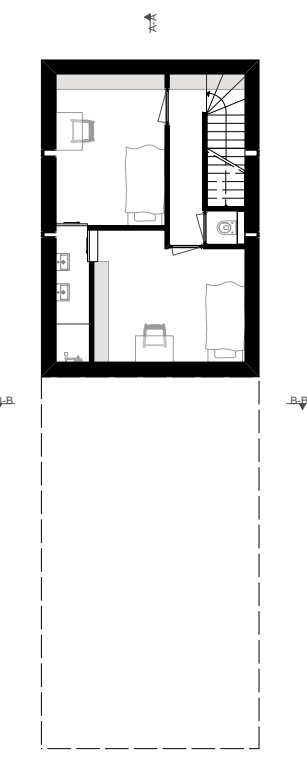

Tweede verdieping

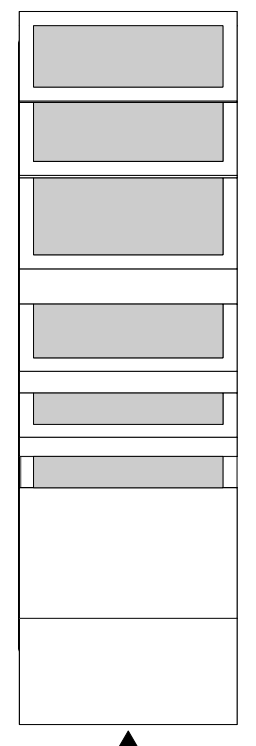

Dakaanzicht

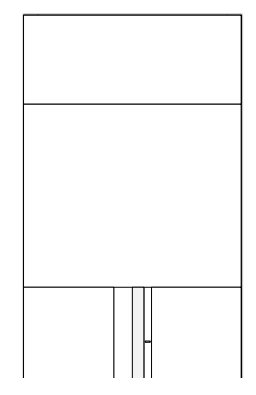

Voorgevel

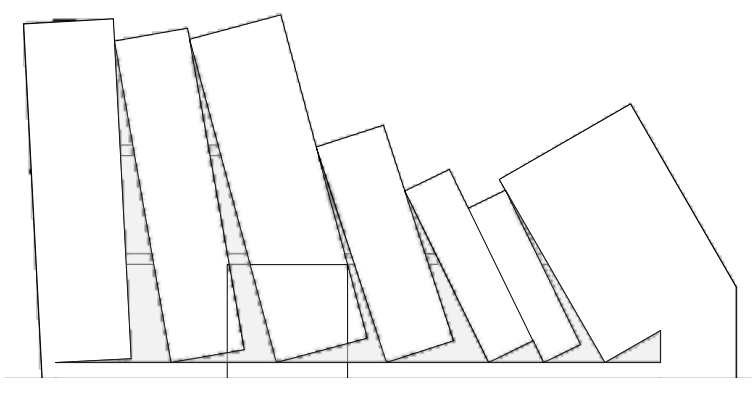

Linkergevel

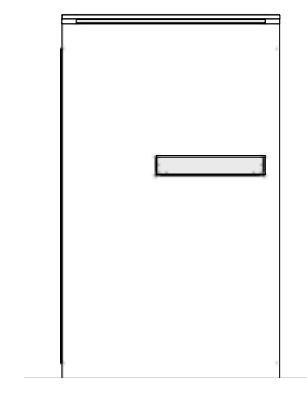

Achtergevel

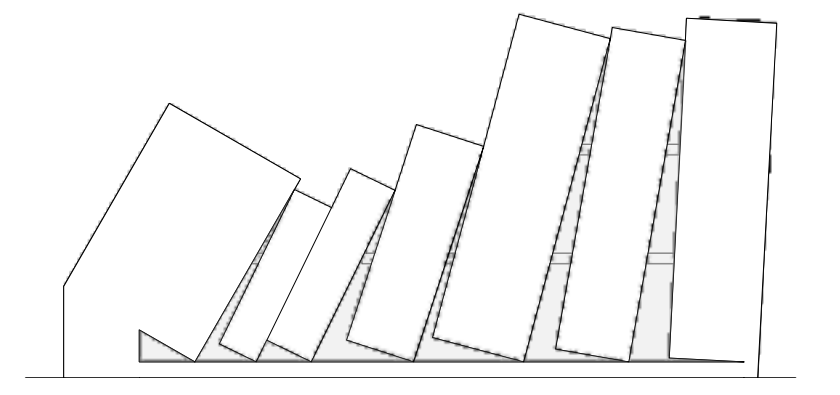

Rechtergevel

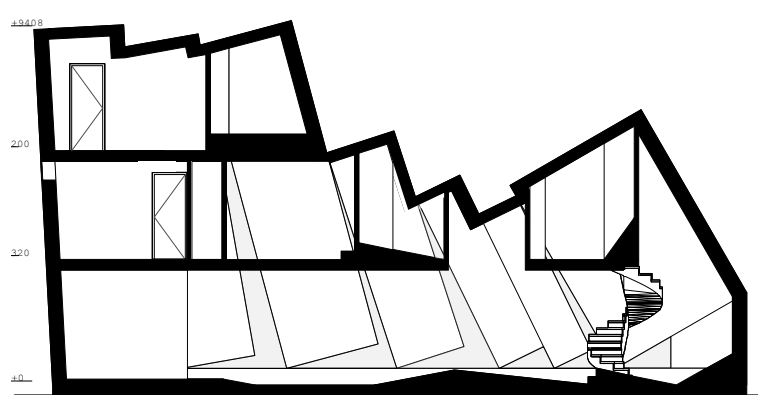

Doorsnede A-A'

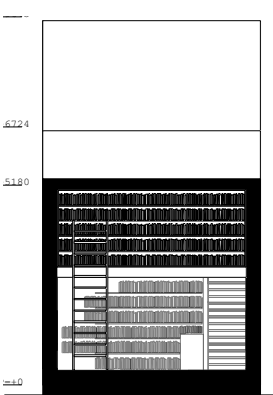

Doorsnede B-B'

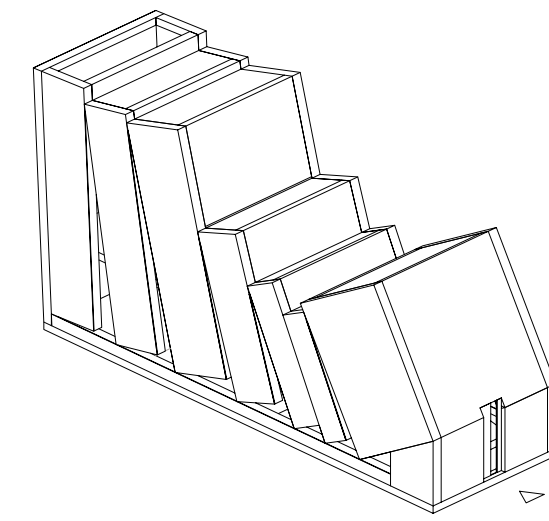

Opgave 5 | The center with a view | Woning zonder gangen | 1:200

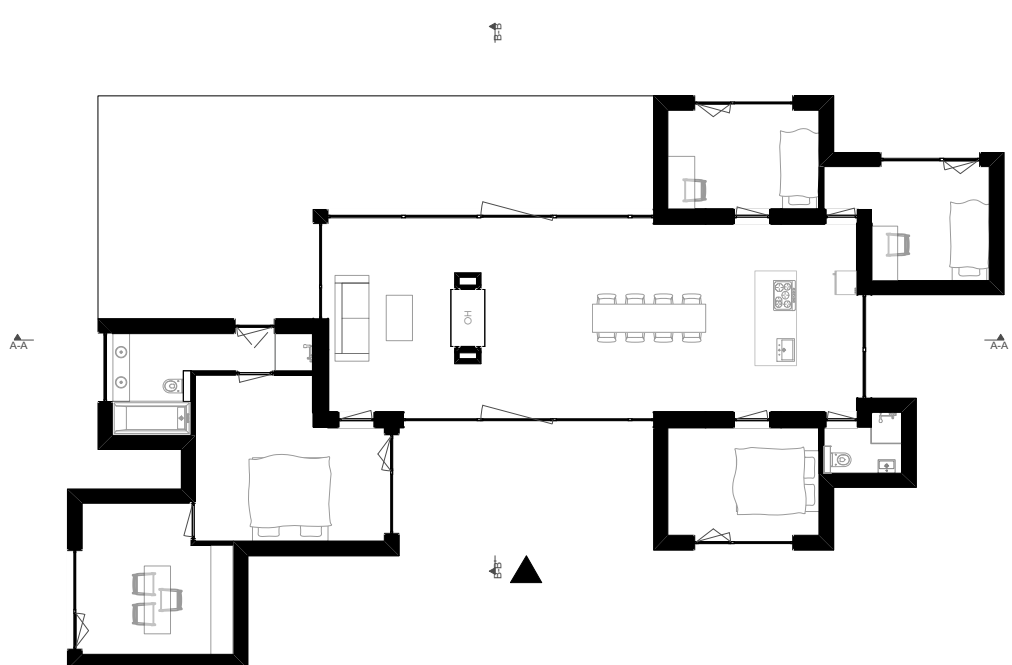

Begane grond

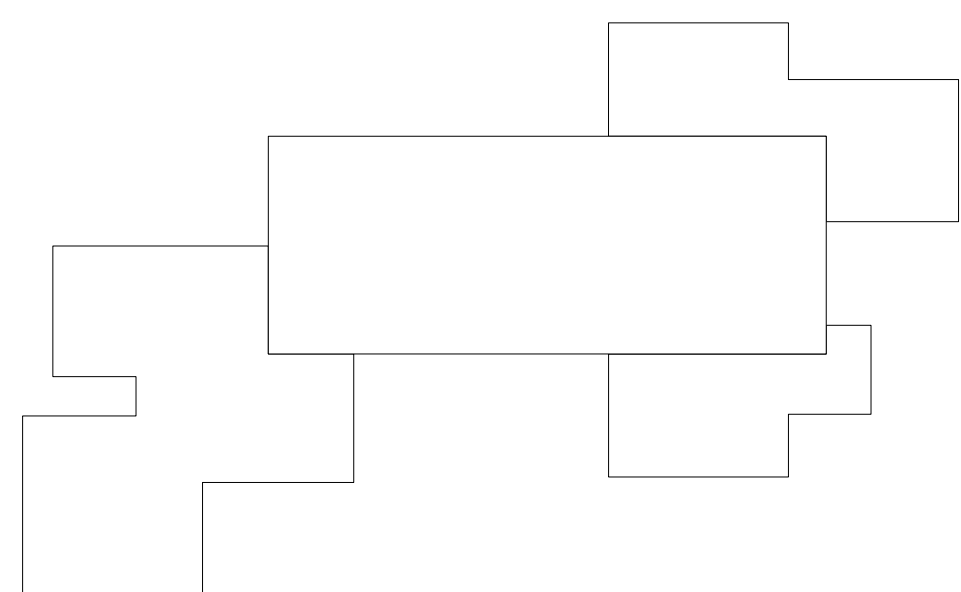

Eerste verdieping

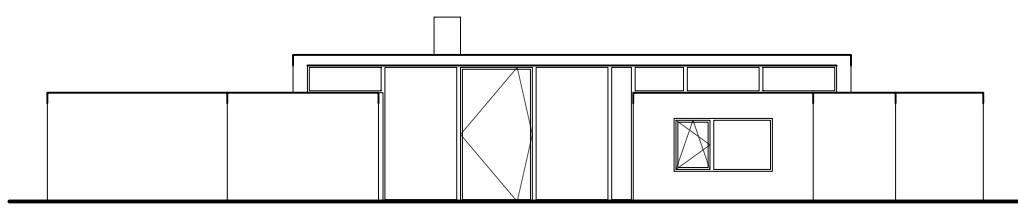

Voorgevel

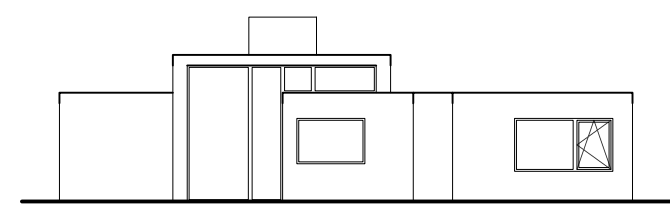

Linkergevel

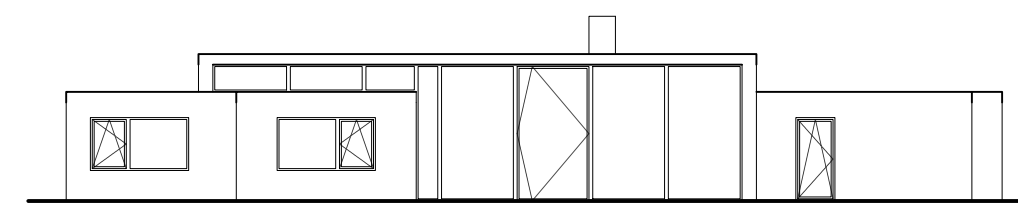

Achtergevel

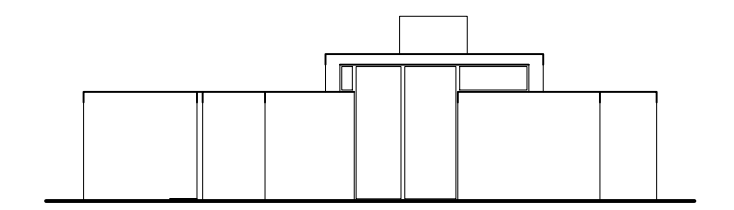

Rechtergevel

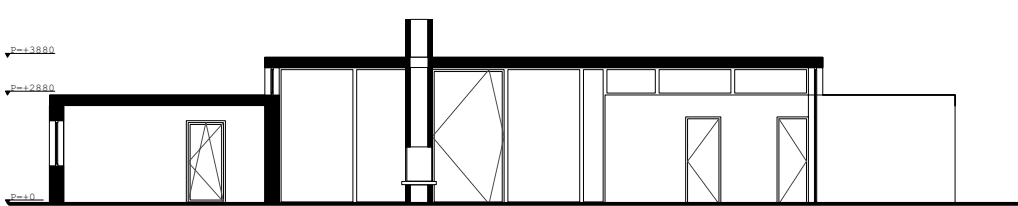

Voorgevel

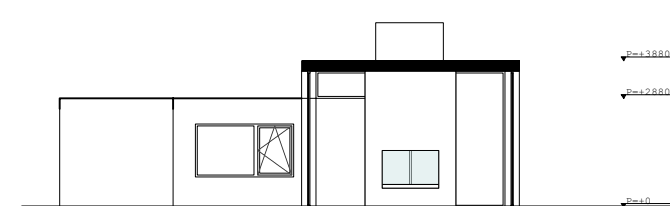

Linkergevel

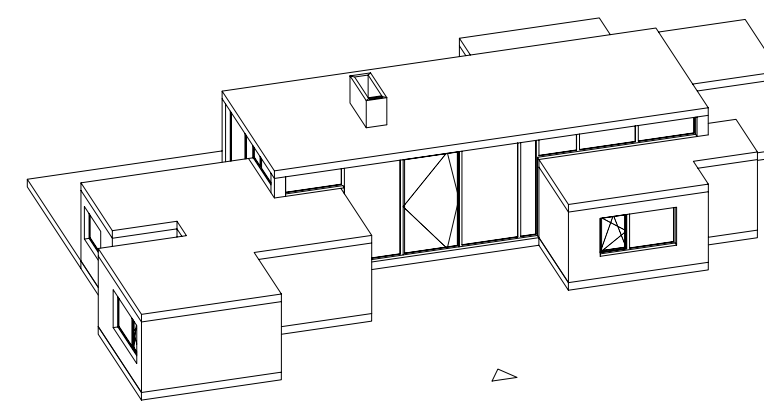

Opgave 6 | Stedenbouwkundig plan | 1:5000

Doorsnede A-A'

Doorsnede B-B'

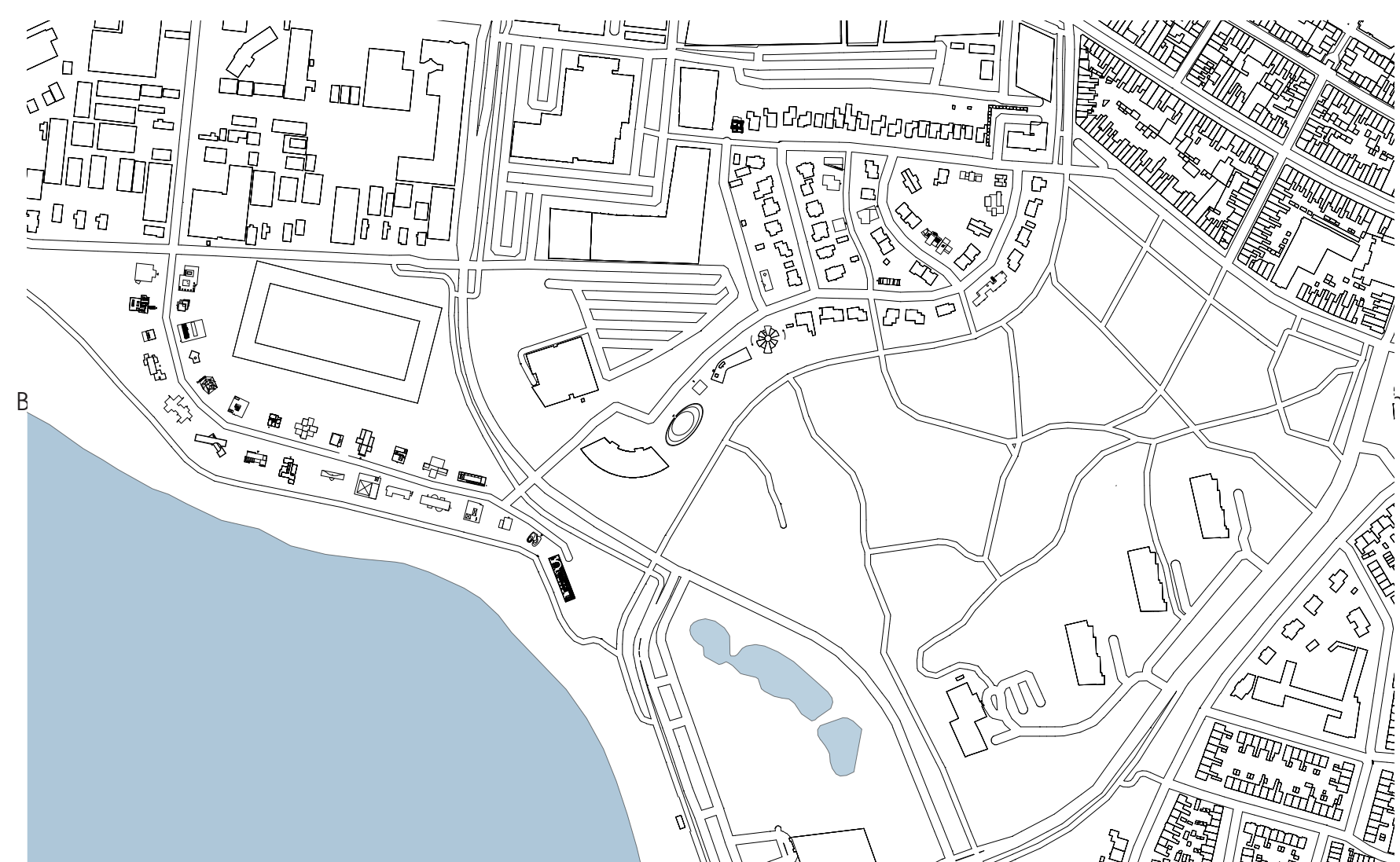

Stedenbouwkundig plan, Bergen op Zoom

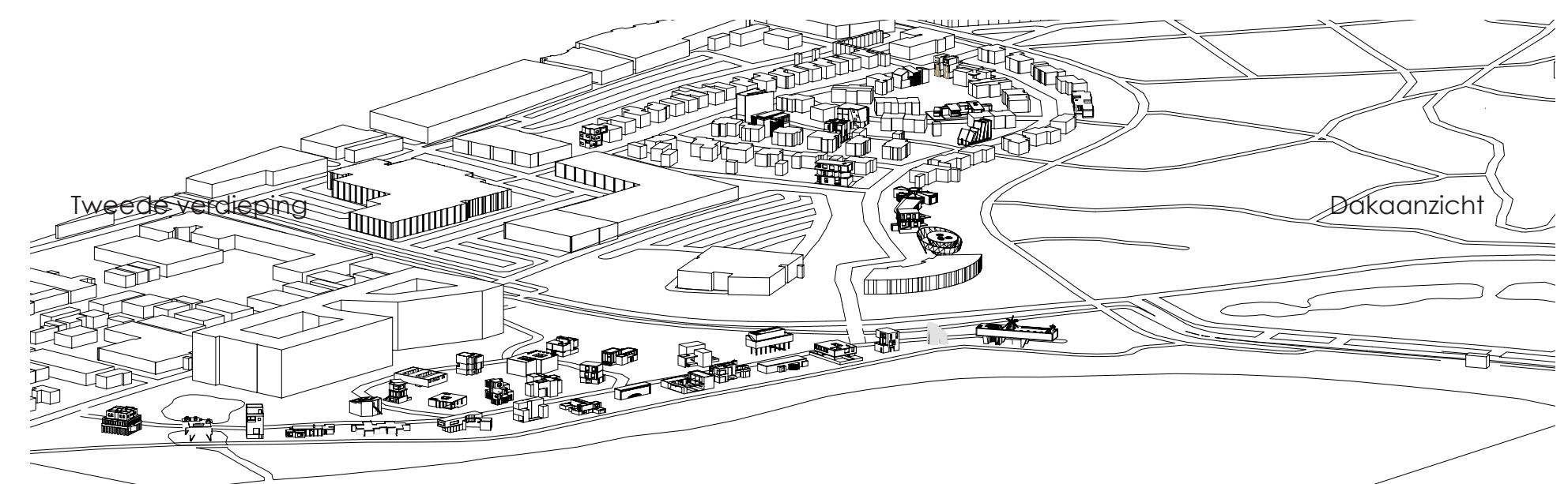

Overview | Bergen op Zoom

Voorgevel

Linkergevel

Achtergevel

Rechtergevel

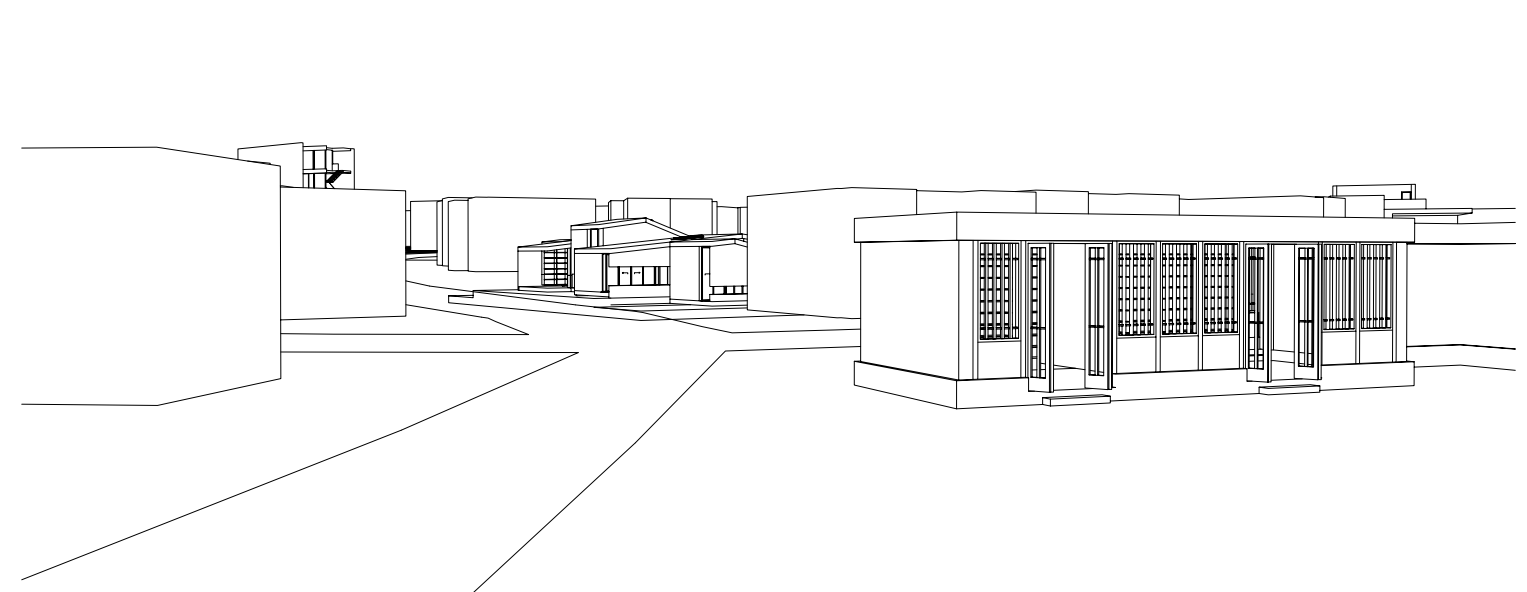

Doorsnede A-A'

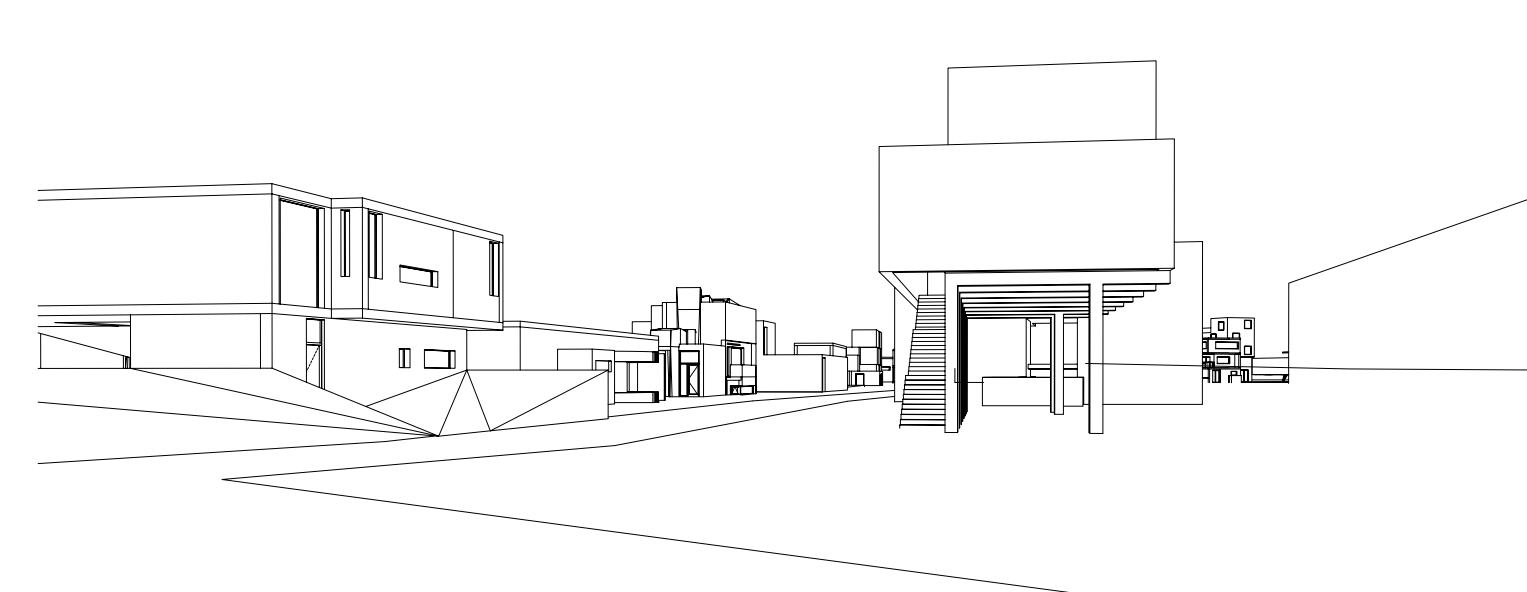

Doorsnede B-B'

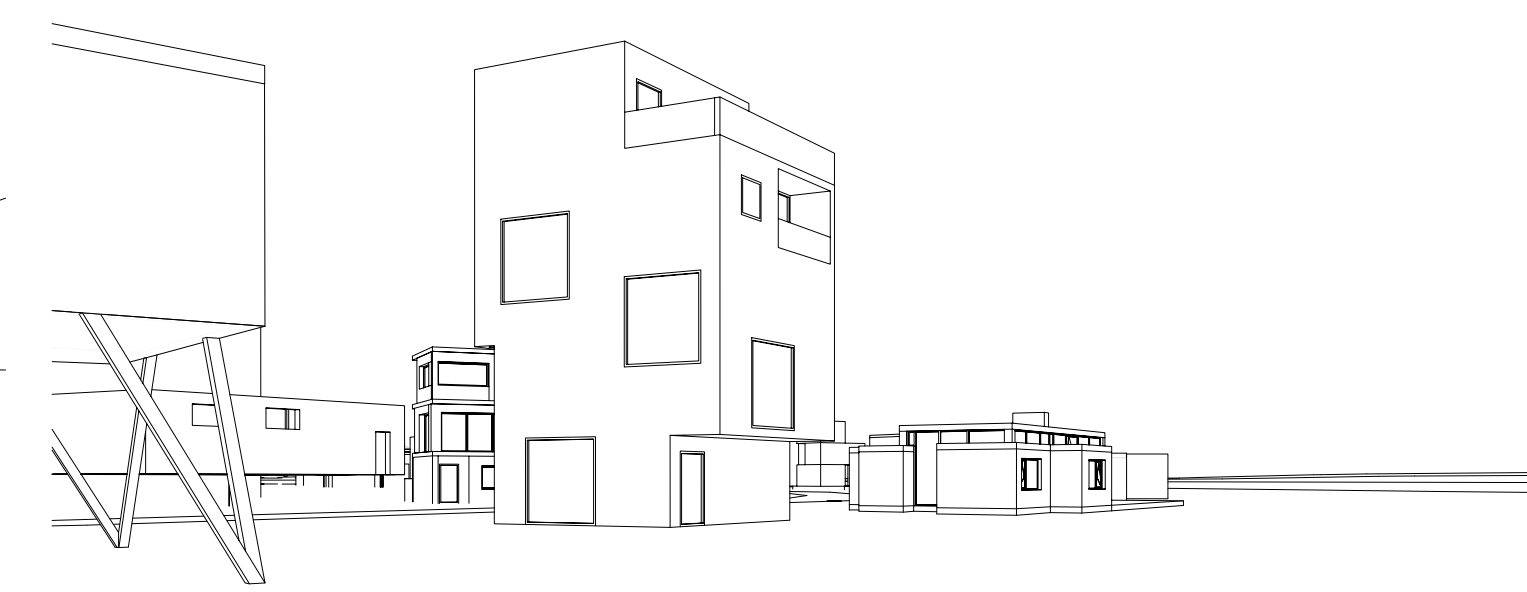

Achtergevel

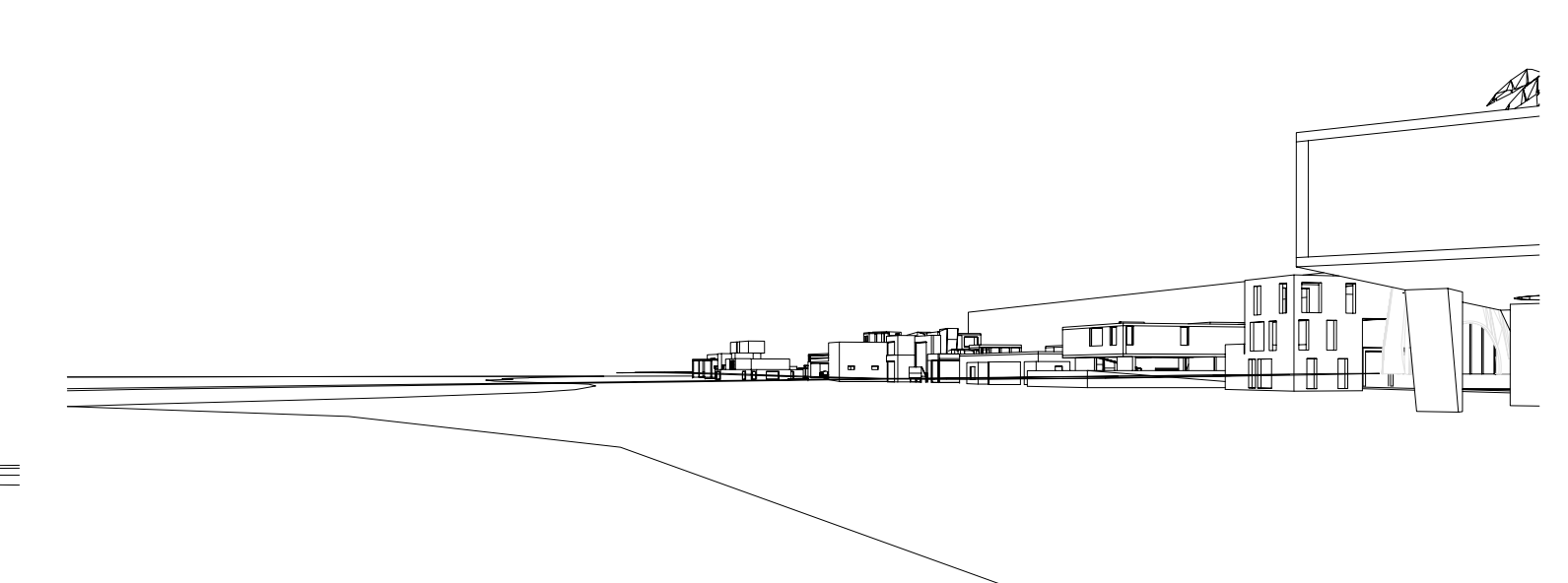

Rechtergevel